

# MICRO SERVOVALVE

# E024



**Low Weight and Small Size:** The E024 Servo Valve is significantly reduced in size and weight compared to the E030 series, making it ideal for motorsport applications where weight and size are critical factors.

**High Performance:** Despite its reduced size, the E024 Servo Valve retains a high flow capability of up to 7.5 l/min (1.98 USg/min), meeting the requirements of the vast majority of motorsport applications.

**Proven Design:** The E024 Servo Valve was developed from the proven E030 series aerospace servo valve, which is widely used for flight control in civil and military aircraft. This ensures its reliability and effectiveness.

**Robust Construction:** The E024 Servo Valve retains the robust two-stage nozzle flapper construction of the 30/50 Series Valve, ensuring it can meet the extreme performance and environmental demands of the motorsport industry.

**Wide Application:** While it is designed to meet the unique challenges of motorsport, particularly Formula 1, the E024 Servo Valve's features also make it suitable for other high-performance applications.

## Available in two basic versions

**High Performance:** Designed for use in applications involving position, pressure and force, where rapid response and pinpoint accuracy are of the utmost importance.

**High Efficiency:** Designed to achieve high dynamics with low parasitic losses.

## BENEFITS

+ Ultra light-weight **95 g (3.35 oz)**

+ Compact package

+ High power density

+ Low input signal (**10 mA**)

+ Compatible with F1 ECU

+ Fast response to command inputs

+ Excellent energy efficiency

+ High peak flow capability

+ Precise, repeatable characteristic control

## TYPICAL APPLICATIONS

- Formula 1 (Throttle actuation, differential control, gearbox actuation, power assisted steering, clutch control, waste-gate control)
- Medical prosthetics
- Subsea equipment
- Special effects in film and theatre
- Mobile robotics

## FIA APPROVED ELECTRONICS

All Moog electro-hydraulic products used in Formula 1 are homologated by the FIA, indicating they are approved for use with the mandated Formula 1 Electronic Control Unit (ECU).



# MOOG

Shaping the way our world moves™

# SPECIFICATIONS

## TECHNICAL DATA E024 MICRO SERVO VALVES

	High Response	High Efficiency
<b>Maximum Supply Pressure:</b>	280 Bar (4061 PSI)	
<b>Valve Function:</b>	Axis-cut linear flow control. Axis-cut flow control with dual gain [Ratio 1:2.5]. Contact Moog for slightly over-lapped variants.	
<b>Rated Flow: @ 70 Bar (1015 PSI) Valve Pressure Drop</b>	Axis-Cut: 0.4, 1.0, 1.5, 2.0, 3.8, 5.0, 7.5 l/m. (0.1, 0.3, 0.4, 0.5, 1.0, 1.3, 2.0 USg/min) Dual Gain: 3.8, 7.0 l/min (1.0, 1.8 USg/min) NB Flow Tolerance +/-10%.	
<b>Main Stage Pilot Leakage Flow:</b>	Pilot stage flow: < 0.30 l/min (0.08 USg/min) (std version).	Pilot stage flow: < 0.20 l/min (0.05 USg/min).
<b>Electrical Input Signal: (coils in parallel)</b>	+/- 10 mA into a 360 ohm. Inductance 1.4 Henry.	
<b>Dynamic Performance:</b>	25% signal @ 210 Bar (3045 PSI) & 40 °C (104 °F) 90° phase lag > 250 Hz -3dB attenuation > 250 Hz. 100% slew response <1.8 ms	25% signal @ 210 Bar (3045 PSI) & 40 °C (104 °F) 90° phase lag > 250 Hz -3dB attenuation > 150 Hz. 100% slew response <2.6 ms
<b>Null Shift:</b>	With supply pressure: < 3% of full signal over the range of 124 Bar (1798 PSI) -228 Bar (3307 PSI). With fluid temperature < 5% of full signal over a range of 35-135 °C (95 °F-275 °F).	
<b>Accuracy of Flow Control:</b>	Hysteresis < 3%. Threshold < 0.5%.	Hysteresis < 3% Threshold < 1%
<b>Environmental Survivability Limits:</b>	-40 °C (-40 °F) to +165 °C (329 °F) & 50 G shock in any direction.	
<b>Mass:</b>	95 g (3.35 oz).	

### ENVIRONMENTAL OPERATING ENVELOPE FOR ALL E024 SERVO VALVES

<b>Pressure Supply:</b>	140 Bar (2030 PSI) - 280 Bar (4061 PSI).
<b>Return Line Pressure:</b>	2 Bar (29 PSI) - 5 Bar (72 PSI).
<b>Temperature Range:</b>	-20 °C (-4 °F) - 135 °C (0 - 275 °F).
<b>Fluids Viscosity:</b>	> 4 CSt.
<b>Filtration:</b>	NAS 1638 CLASS 3 / ISO 4406 14/12/9 or better. It may be possible to operate the valve in certain applications outside of these design limits, but this must be checked and validated by the customer.
<b>Operation of Valves in Close Proximity:</b>	Valves mounted in close proximity may experience magnetic interaction. The degree of interaction depends on the installation and may be minimized by the use of external shielding.

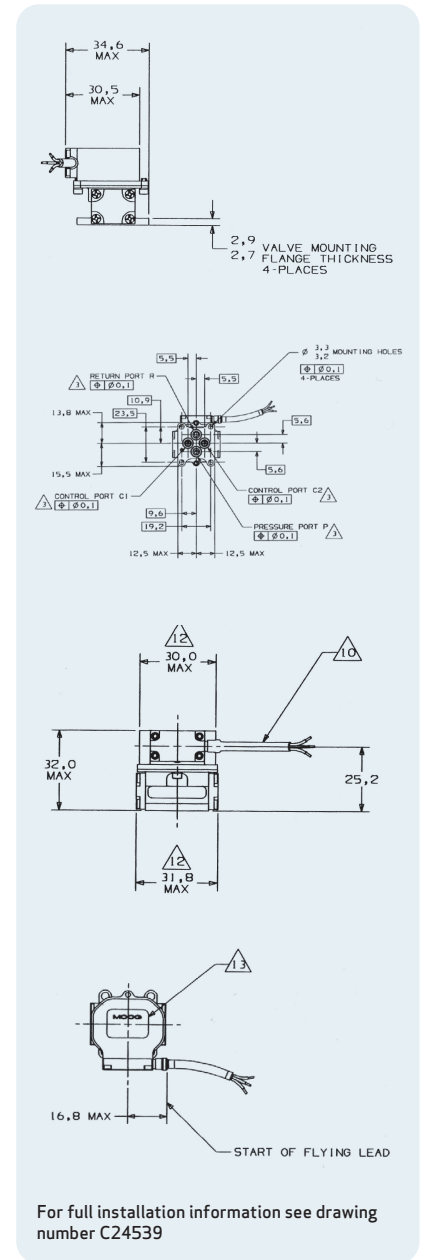

For further information, visit:  
[www.moog.com/miniature](http://www.moog.com/miniature)

This technical data is based on current available information and is subject to change at anytime by Moog. Performance for specific systems or applications may vary.

Moog is a registered trademark of Moog Inc. and its subsidiaries. All trademarks as indicated herein are the property of Moog Inc. and its subsidiaries. © 10/2025 Moog Inc. All rights reserved. All changes are reserved. E024 Datasheet Servo Valve CDL 68251

# MOOG

SHAPING THE WAY OUR WORLD MOVES™

**Moog Industrial Group.**  
Ashchurch Parkway, Tewkesbury,  
Glos. GL20 8TU UK  
**Tel:** +44 (0)1684 858000