

ELECTROHYDROSTATIC PUMP UNIT

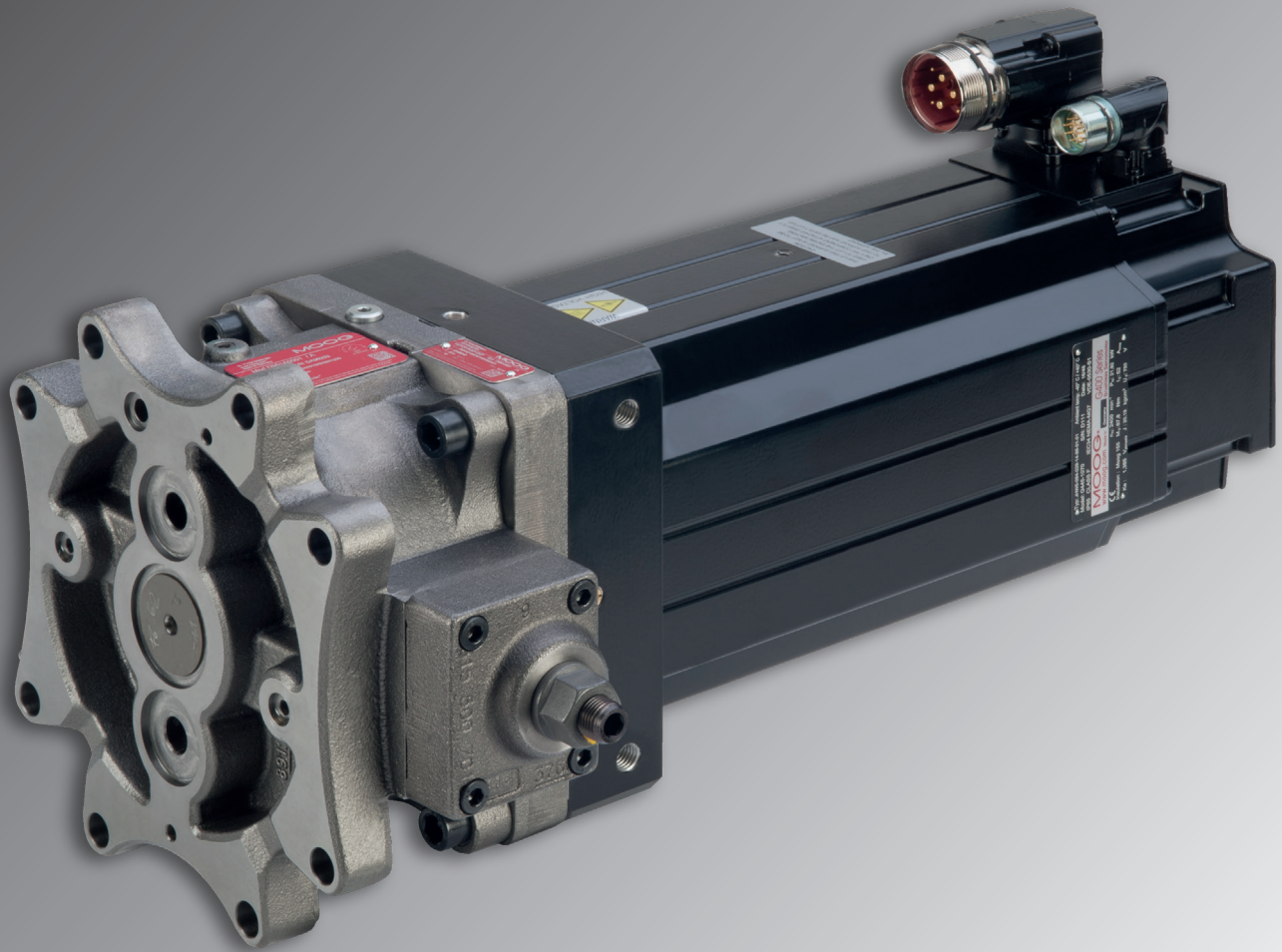

Rev. L, February 2026

MODULAR ELECTROHYDROSTATIC PUMP UNIT
FOR INDUSTRIAL APPLICATIONS

MOOG | Shaping the way our world moves™

Whenever the highest levels of motion control performance and design flexibility are required, you'll find Moog expertise at work. Through collaboration, creativity and world-class technological solutions, we help you overcome your toughest engineering obstacles, enhance your machine's performance, and help take your thinking further than you ever thought possible.

INTRODUCTION.....	2
Product Overview	3
TECHNICAL DATA	6
EPU-G Size 13.....	6
EPU-G Size 20.....	15
EPU-G Size 13 and 20 - Mounting Pattern and Pump Front View	24
EPU Size 19.....	25
EPU Size 32.....	35
EPU Size 80.....	45
EPU Size 140.....	55
Electrical Interfaces	65
ORDERING INFORMATION.....	67
Orientation of Electrical Connectors and Liquid Cooling Ports	69
Ordering Code	71
Notes	73
CONTACT.....	74

This catalog is for users with technical knowledge. To ensure all necessary characteristics for function and safety of the system, the user has to check the suitability of the products described herein. The products described in this document are subject to change without notice. In case of doubt, please contact Moog.

Moog is a registered trademark of Moog Inc. and its subsidiaries. All trademarks as indicated herein are the property of Moog Inc. and its subsidiaries. For the full disclaimer refer to www.moog.com/literature/disclaimers.

For the most current information, visit www.moog.com/industrial or contact your local Moog office.

PRODUCT OVERVIEW

Moog Electrohydrostatic Pump Unit and Electrohydrostatic Actuation System

Moog Electrohydrostatic Pump Units are emerging as a viable option for industrial machine builders as the design combines the best of both electromechanical and electrohydraulic technologies. These highly integrated, compact alternatives to traditional hydraulic solutions offer superior performance and efficiency.

This catalog details the EPU and EPU-G used in electrohydrostatic actuation systems, such as the Moog EAS. They are capable of operating in both 2-quadrant and 4-quadrant modes and feature a mechanical interface that allows direct connection to hydraulic cylinders or manifolds.

The EPU-G in sizes 13 and 20 utilize an internal gear pump to generate flow.

The EPU in sizes 19, 32, 80 and 140 use a radial piston pump available in two versions: Fixed or dual displacement. As a fixed displacement pump, the pump permanently delivers a certain volume per revolution. The dual displacement pump version can be switched between two fixed volumes (V_{\max} and V_{\min} adjustable) during operation, see table in section "Ordering Code" on page 72.

The Moog EAS is a modular actuation system comprised of an EPU(-G), Servo Drive (MSD) and manifold. Adding a cylinder as part of the system is also a common option.



EPU-G

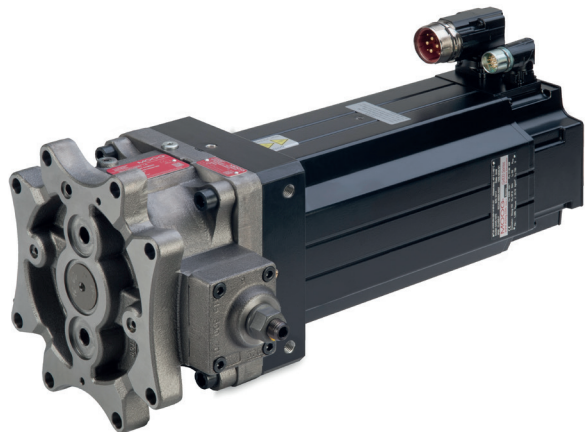

EPU

PRODUCT OVERVIEW

EPU-G - Sizes 13 and 20

Performance Specifications

Size	013	020
Pump version	Internal gear pump	
Maximum flow	57 l/min (15.1 gpm)	83 l/min (21.9 gpm)
Maximum pressure ports A and B	345 bar (5,004 psi)	
Maximum housing pressure ¹⁾	Refer to speed/pressure curve	
Motor version	Brushless servo motor: natural, fan or liquid (oil/water) cooled	
Temperature range		
Ambient	-20 to +60 °C (-4 to +140 °F)	
Fluid	-20 to +80 °C (-4 to +176 °F) (leakage oil on port L)	
Seal material	FKM/NBR	
Operating fluid	Mineral oil according to DIN 51524, HFD and others upon request	
Viscosity ²⁾	<ul style="list-style-type: none"> Allowable viscosity operational range from 12 to 100 mm²/s (cSt). Recommended hydraulic fluid viscosity class VG 46 to VG 100 according to ISO 3448. Maximum viscosity 500 mm²/s (cSt) during start-up with electric motor at 1,800 rpm 	
System filtration	<ul style="list-style-type: none"> NAS 1638, class 9 ISO 4406 class 19/17/14; obtained with filter fineness of $\beta_{20} = 75$ 	
Installation position	Any	
Installation note	Load holding up to 15% of the duty cycle and a maximum cycle time of 1 minute.	

1) Maximum housing pressure $p_{L,max}, p_F = f(n)$, see diagram below.

2) For more information see EPU user manual.

Housing Pressure (p_F)

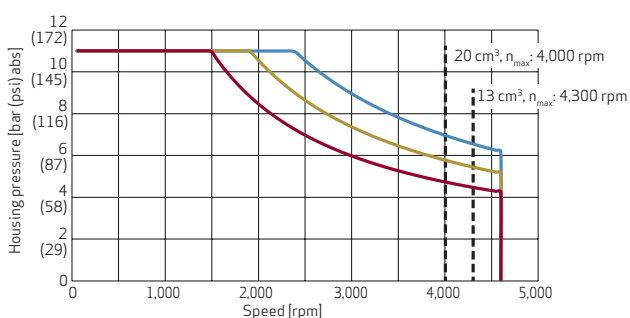

Preload Pressure Suction Port (p_A, p_B)

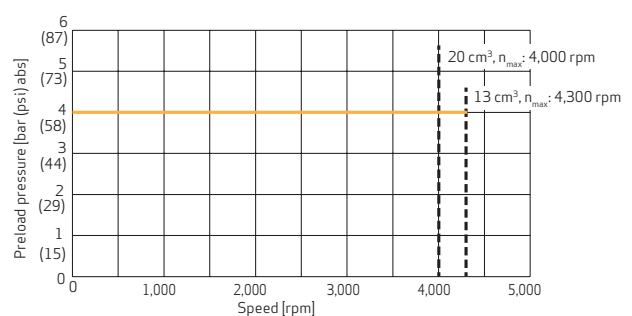

13 cm ³	SOC	SOF	SOW
	MOC	MOF	MOW
	HOC	HOE	HOW
20 cm ³	SOC	SOF	SOW
	MOC	MOF	MOW
	HOC	HOE	HOW

PRODUCT OVERVIEW

EPU - Sizes 19, 32, 80 and 140

Performance Specifications

Size	019	032	080	140
Pump version	Radial piston pump, constant, dual or variable displacement			
Maximum flow	85 l/min (22.5 gpm)	118 l/min (31.2 gpm)	216 l/min (57.1 gpm)	322 l/min (85.1 gpm)
Maximum pressure ports A and B	350 bar (5,076 psi)			
Maximum housing pressure ¹⁾	10 bar (145 psi)			
Motor version	Brushless servo motor: natural, fan or liquid cooled			
Temperature range				
Ambient	-15 to +60 °C (+5 to +140 °F)			
Fluid	-15 to +80 °C (+5 to +176 °F)			
Seal material	FKM			
Pilot pressure supply ²⁾	External			
Operating fluid	Mineral oil according to DIN 51524, HFD, others upon request			
Viscosity ³⁾	<ul style="list-style-type: none"> Allowable viscosity operational range 12 to 100 mm²/s (cSt) Recommended hydraulic fluid viscosity class VG 46 to VG 100 according to ISO 3448 Maximum viscosity 500 mm²/s (cSt) during start-up with electric motor at 1,800 rpm 			
System filtration	<ul style="list-style-type: none"> NAS 1638, class 9 ISO 4406, class 20/18/15; obtained with filter fineness of $\beta_{20} = 75$ 			
Installation position	Any			
Installation note	<p>To avoid pump damages the housing pressure p_L must not exceed the pressure in the low pressure line (p_A or p_B) by more than 1 bar. Design the drain line with lowest possible pressure losses. Maximal pump speed is preload pressure dependent on suction line, see diagram below.</p> <p>The fluid temperature in the tank shall not exceed the temperature of the pump by more than +25 °C (+77 °F). If this should occur, the pump shall be jog started for intervals of approximately 1 to 2 seconds until pump casing has heated up.³⁾</p>			

1) Maximum housing pressure $p_{Lmax}, P_{Sp} = f(n)$, see diagram below.

2) For option N1 (dual displacement) only.

3) For more information see EPU user manual.

Housing Pressure (p_{Sp})

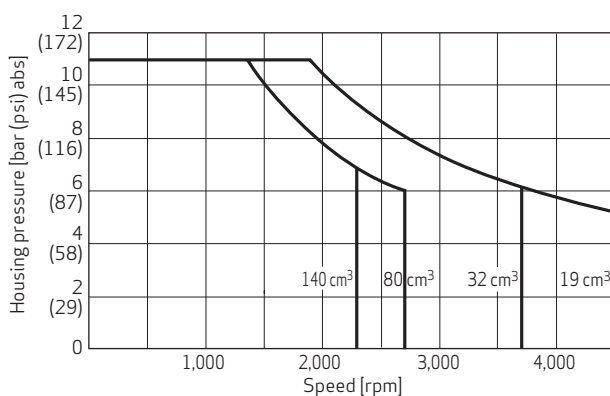

Preload Pressure (p_A, p_B)

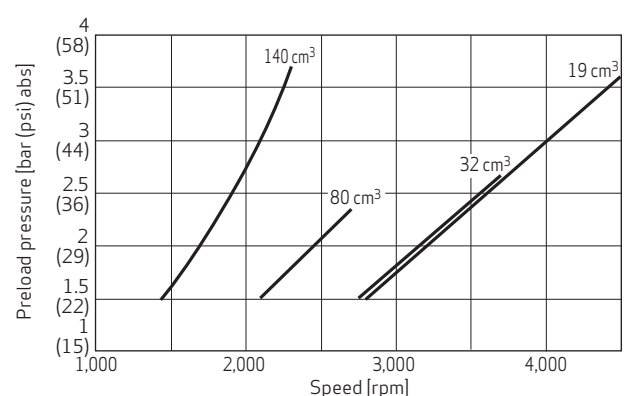

EPU-G SIZE 13

Natural Cooling, S EPU 013 x D GP xx C

Characteristics Table

Performance class		Small	Medium	High
S EPU 013 x D GP		S0 C	M0 C	H0 C
Pump				
Displacement	V_{max}	13 cm ³ /rev (0.79 in ³ /rev)		
Maximum pump speed	n_{max}	4,300 rpm		
Maximum pump acceleration	\dot{n}_{max}	96,400 rpm/s		
Maximum housing pressure ¹⁾	p_{Lmax}, p_F	Refer to speed/pressure curve		
Maximum flow	Q_{max}	57 l/min (15.1 gpm)		
Maximum pressure ports A and B	p_A, p_B	345 bar (5,004 psi)		
Flushing flow rate ⁴⁾	Q_F	1.5 to 2 l/min (0.4 to 0.5 gpm)		
Motor				
Continuous stall torque ³⁾	M_0	24 Nm (212 lbf in)	39 Nm (345 lbf in)	77 Nm (682 lbf in)
Rated torque ³⁾	M_n	15 Nm (133 lbf in)	21 Nm (186 lbf in)	41 Nm (363 lbf in)
Maximum torque	M_{max}	134 Nm (1,186 lbf in)	225 Nm (1,991 lbf in)	267 Nm (2,363 lbf in)
Rated speed	n_n	2,125 rpm	2,100 rpm	1,200 rpm
Maximum speed	n_{max}	Maximum speed see $M = f(n)$ performance curve		
Continuous stall current	I_0	20.73 A _{rms}	24.77 A _{rms}	48.74 A _{rms}
Maximum current	I_{max}	126 A _{rms}	158 A _{rms}	211 A _{rms}
Torque constant	k_t	1.17 Nm/A _{rms} (10.4 lbf in/A _{rms})	1.56 Nm/A _{rms} (13.8 lbf in/A _{rms})	1.59 Nm/A _{rms} (14.1 lbf in/A _{rms})
Voltage constant	k_e	82.93 V _{rms} /1,000 rpm	110.33 V _{rms} /1,000 rpm	105.89 V _{rms} /1,000 rpm
Thermal time constant	t_{th}	2,600 s	4,333 s	2,550 s
Winding resistance at +25 °C	R_{tt}	0.296 Ω	0.287 Ω	0.121 Ω
Winding inductance	L_{tt}	2.370 mH	2.515 mH	1.387 mH
Power connector		Size 1.5 rotatable		
Feedback connector		Signal resolver connector rotatable		
Thermal sensor		NTC 220 kOhm, Pt1000		
EPU unit				
Inertia	J	30.65 kg cm ² (271 10 ⁻⁴ lbf in s ²)	47.44 kg cm ² (420 10 ⁻⁴ lbf in s ²)	263.25 kg cm ² (2,330 10 ⁻⁴ lbf in s ²)
Weight	m	46.7 kg (103.0 lb)	56.7 kg (125.0 lb)	94.0 kg (207.2 lb)
Tightening torque 4xM16x45 -10.9 cylinder head screw		310 Nm (2,744 lbf in)		
Servo drive				
Recommended drive size ²⁾		G392-032 size 4	G392-045 size 5	G392-072 size 5

1) See diagram "Housing Pressure (p_r)" on page 4.

2) See catalog "Modular Multi-Axis Servo Drive Systems (MSD)".

3) Operation in still air with ambient temperatures up to +40 °C (+104 °F). Winding temperature measure up to +110 °C (+230 °F) over ambient.

4) Optional via F port (flushing port).

EPU-G SIZE 13

Natural Cooling, S EPU 013 x D GP xx C

Motor Performance Curves

50 C

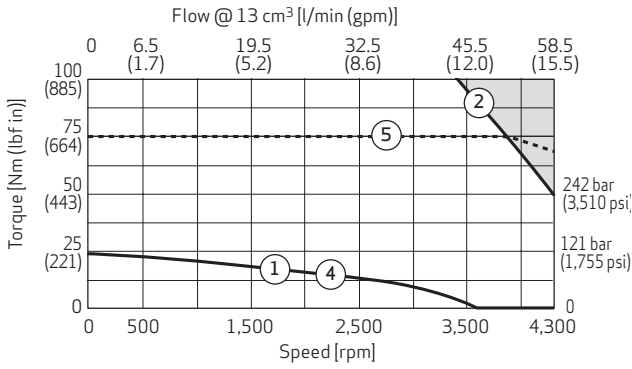

M0 C

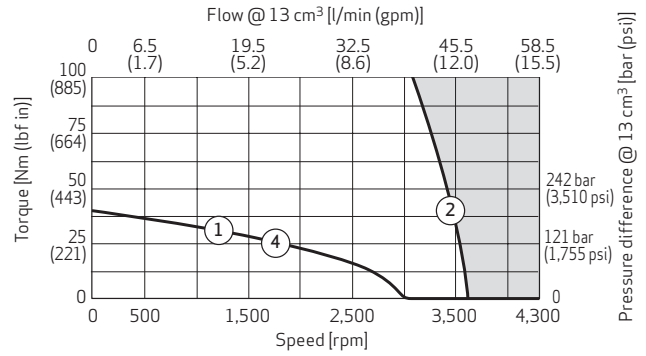

H0 C

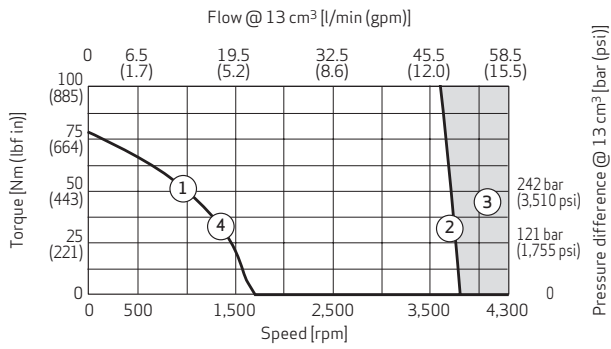

- ① Continuous torque at 110 K temperature difference over ambient, max. winding temperature 150 °C (302 °F)
- ② Maximum torque without field weakening
- ③ Maximum torque with field weakening
- ④ Continuous torque if recommended drive size is used
- ⑤ Maximum torque with field weakening if recommended drive size is used

Notes:

Motor performance with 565 V_{DC} link voltage

Motor performance does not take the pump efficiency into account

Pressure difference $\Delta p = p_A - p_B$

EPU-G SIZE 13

Natural Cooling, S EPU 013 x D GP xx C

Installation Drawings

50 C

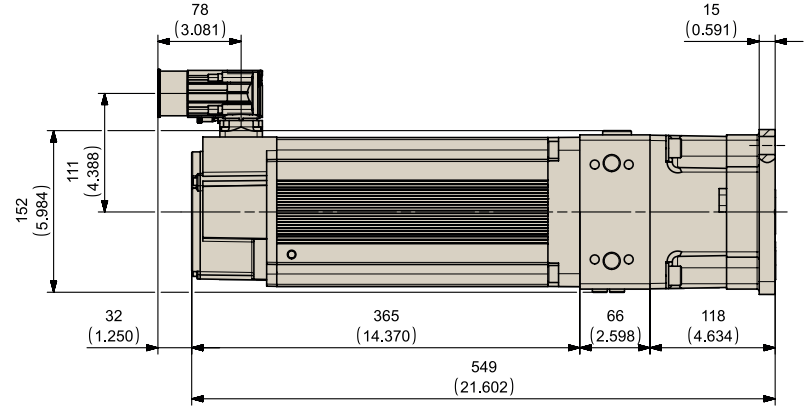

M0 C

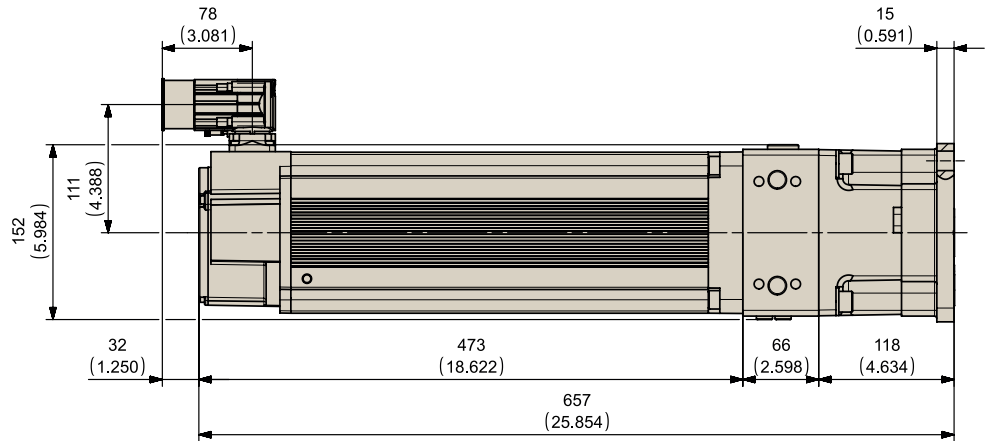

H0 C

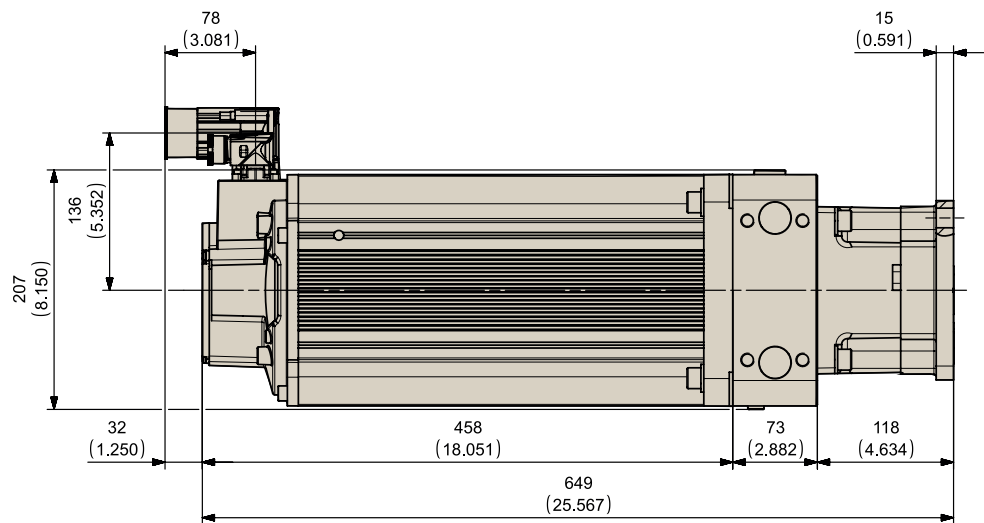

Note: Dimensions mm (inch)

EPU-G SIZE 13

Fan Cooling, S EPU 013 x D GP xx F

Characteristics Table

Performance class		Small	Medium	High
S EPU 013 x D GP		S0 F	M0 F	H0 F
Pump				
Displacement	V_{max}	13 cm ³ /rev (0.79 in ³ /rev)		
Maximum pump speed	n_{max}	4,300 rpm		
Maximum pump acceleration	\dot{n}_{max}	96,400 rpm/s		
Maximum housing pressure ¹⁾	p_{Lmax}, p_F	Refer to speed/pressure curve		
Maximum flow	Q_{max}	57 l/min (15.1 gpm)		
Maximum pressure ports A and B	p_A, p_B	345 bar (5,004 psi)		
Flushing flow rate ⁴⁾	Q_F	1.5 to 2 l/min (0.4 to 0.5 gpm)		
Motor				
Continuous stall torque ³⁾	M_0	25.5 Nm (226 lbf in)	34 Nm (301 lbf in)	61 Nm (540 lbf in)
Rated torque ³⁾	M_n	18 Nm (159 lbf in)	24 Nm (212 lbf in)	40 Nm (354 lbf in)
Maximum torque	M_{max}	95 Nm (841 lbf in)	134 Nm (1,186 lbf in)	225 Nm (1,991 lbf in)
Rated speed	n_n	3,300 rpm	3,400 rpm	2,600 rpm
Maximum speed	n_{max}	Maximum speed see $M = f(n)$ performance curve		
Continuous stall current	I_0	20.4 A _{rms}	28.81 A _{rms}	38.8 A _{rms}
Maximum current	I_{max}	85 A _{rms}	126 A _{rms}	158 A _{rms}
Torque constant	k_t	1.25 Nm/A _{rms} (11.1 lbf in/A _{rms})	1.17 Nm/A _{rms} (10.4 lbf in/A _{rms})	1.57 Nm/A _{rms} (13.9 lbf in/A _{rms})
Voltage constant	k_e	88.12 V _{rms} /1,000 rpm	82.93 V _{rms} /1,000 rpm	110.33 V _{rms} /1,000 rpm
Thermal time constant	t_{th}	1,722 s	2,600 s	4,333 s
Winding resistance at +25 °C	R_{tt}	0.576 Ω	0.296 Ω	0.287 Ω
Winding inductance	L_{tt}	3.969 mH	2.356 mH	2.501 mH
Power connector		Size 1 rotatable	Size 1.5 rotatable	
Feedback connector		Signal resolver connector rotatable		
Fan connector		Size 1 rotatable		
Thermal sensor		NTC 220 kOhm, Pt1000		
EPU unit				
Inertia	J	22.26 kg cm ² (197 10 ⁻⁴ lbf in s ²)	30.65 kg cm ² (271 10 ⁻⁴ lbf in s ²)	47.44 kg cm ² (420 10 ⁻⁴ lbf in s ²)
Weight	m	44.3 kg (97.7 lb)	49.6 kg (109.2 lb)	60.0 kg (132.3 lb)
Tightening torque 4xM16x45 -10.9 cylinder head screw		310 Nm (2,744 lbf in)		
Servo drive				
Recommended drive size ²⁾		G392-032 size 4	G392-045 size 5	

1) See diagram "Housing Pressure (p_r)" on page 4.

2) See catalog "Modular Multi-Axis Servo Drive Systems (MSD)".

3) Operation in still air with ambient temperatures up to +40 °C (+104 °F). Winding temperature measure up to +110 °C (+230 °F) over ambient.

4) Optional via F port (flushing port).

EPU-G SIZE 13

Fan Cooling, S EPU 013 x D GP xx F

Motor Performance Curves

S0 F

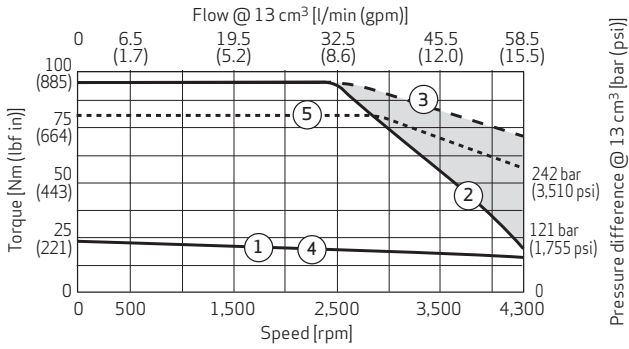

M0 F

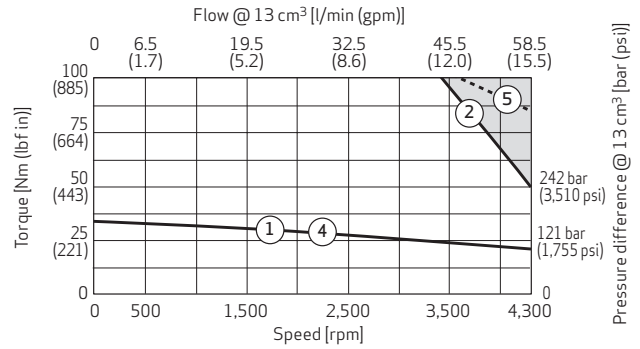

H0 F

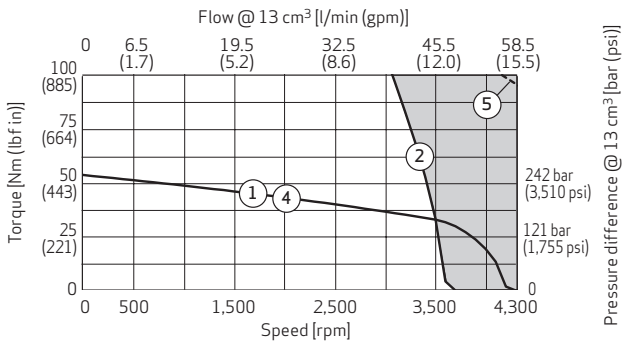

- ① Continuous torque at 110K temperature difference over ambient, max. winding temperature 150 °C (302 °F)
- ② Maximum torque without field weakening
- ③ Maximum torque with field weakening
- ④ Continuous torque if recommended drive size is used
- ⑤ Maximum torque with field weakening if recommended drive size is used

Notes:

Motor performance with 565 V_{DC} link voltage

Motor performance does not take the pump efficiency into account

Pressure difference $\Delta p = p_A - p_B$

EPU-G SIZE 13

Fan Cooling, S EPU 013 x D GP xx F

Installation Drawings

S0 F

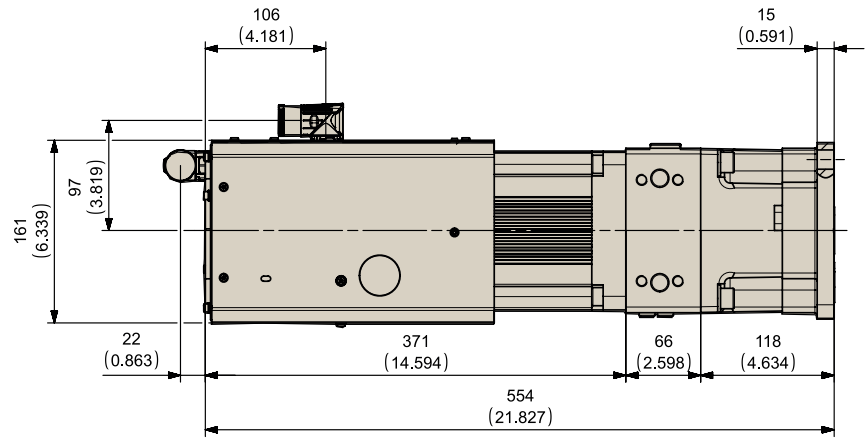

M0 F

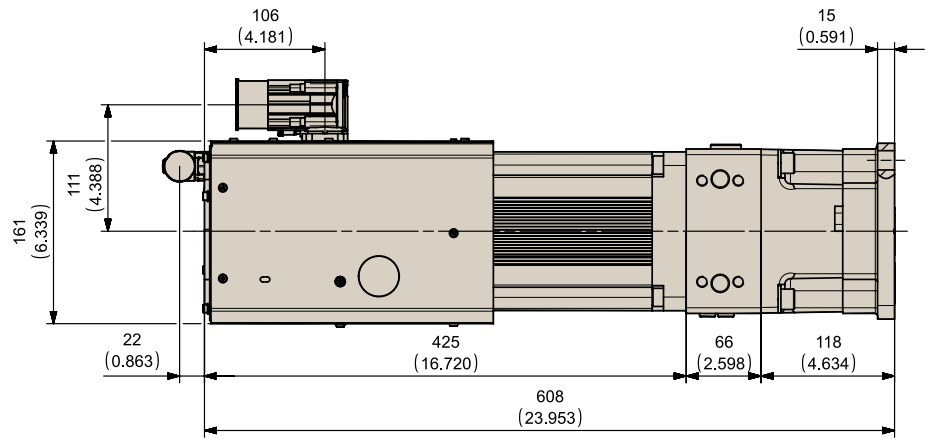

H0 F

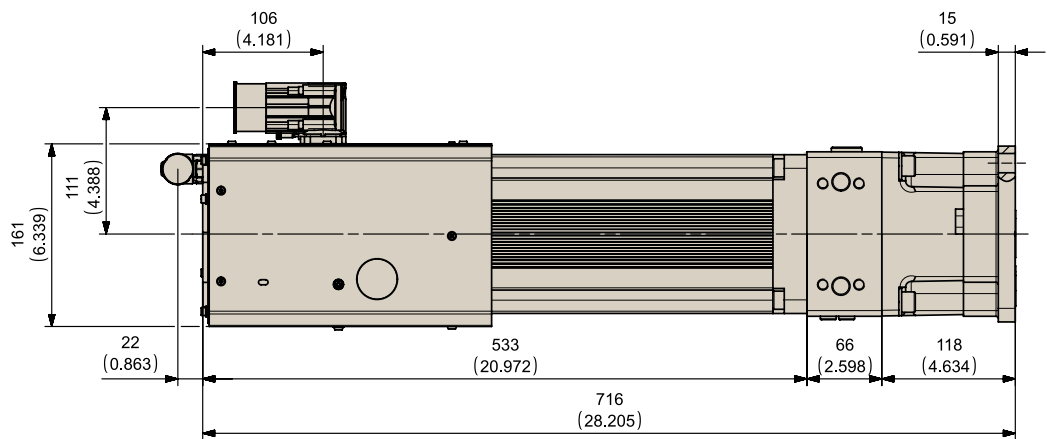

Note: Dimensions mm (inch)

EPU-G SIZE 13

Liquid Cooling, S EPU 013 x D GP xx W

Characteristics Table

Performance class		Small	Medium	High
S EPU 013 x D GP		S0W	M0W	H0W
Pump				
Displacement	V_{max}	13 cm ³ /rev (0.79 in ³ /rev)		
Maximum pump speed	n_{max}	4,300 rpm		
Maximum pump acceleration	\dot{n}_{max}	96,400 rpm/s		
Maximum housing pressure ¹⁾	$p_{L,max}, p_F$	Refer to speed/pressure curve		
Maximum flow	Q_{max}	57 l/min (15.1 gpm)		
Maximum pressure ports A and B	p_A, p_B	345 bar (5,004 psi)		
Flushing flow rate ⁴⁾	Q_F	1.5 to 2 l/min (0.4 to 0.5 gpm)		
Motor				
Continuous stall torque ³⁾	M_0	27 Nm (239 lbf in)	40 Nm (354 lbf in)	60 Nm (531 lbf in)
Rated torque ³⁾	M_n	25 Nm (221 lbf in)	37 Nm (327 lbf in)	54 Nm (478 lbf in)
Maximum torque	M_{max}	53 Nm (469 lbf in)	95 Nm (841 lbf in)	135 Nm (1,195 lbf in)
Rated speed	n_n	3,100 rpm	3,000 rpm	3,400 rpm
Maximum speed	n_{max}	Maximum speed see $M = f(n)$ performance curve		
Continuous stall current	I_0	22.15 A _{rms}	31.9 A _{rms}	51.08 A _{rms}
Maximum current	I_{max}	47 A _{rms}	85 A _{rms}	126 A _{rms}
Torque constant	k_t	1.23 Nm/A _{rms} (10.9 lbf in/A _{rms})	1.24 Nm/A _{rms} (11.0 lbf in/A _{rms})	1.17 Nm/A _{rms} (10.4 lbf in/A _{rms})
Voltage constant	k_e	94.8 V _{rms} /1,000 rpm	88.12 V _{rms} /1,000 rpm	82.93 V _{rms} /1,000 rpm
Thermal time constant	t_{th}	1,800 s	234 s	353 s
Winding resistance at +25 °C	R_{tt}	1.147 Ω	0.576 Ω	0.296 Ω
Winding inductance	L_{tt}	7.729 mH	3.972 mH	2.357 mH
Power connector		Size 1 rotatable	Size 1.5 rotatable	Size 1.5 rotatable
Feedback connector		Signal resolver connector rotatable		
Thermal sensor		NTC 220 kOhm, Pt1000		
Cooling water flow rate	Q_w	6 l/min (1.6 gpm)	8 l/min (2.1 gpm)	8 l/min (2.1 gpm)
EPU unit				
Inertia	J	16.85 kg cm ² (149 10 ⁻⁴ lbf in s ²)	22.26 kg cm ² (197 10 ⁻⁴ lbf in s ²)	30.65 kg cm ² (271 10 ⁻⁴ lbf in s ²)
Weight	m	40.5 kg (89.3 lb)	43.5 kg (95.9 lb)	49 kg (108.0 lb)
Tightening torque 4xM16x45 -10.9 cylinder head screw		310 Nm (2,744 lbf in)		
Servo drive				
Recommended drive size ²⁾		G392-024 size 4	G392-045 size 5	G392-060 size 5

1) See diagram "Housing Pressure (p_F)" on page 4.

2) See catalog "Modular Multi-Axis Servo Drive Systems (MSD)".

3) Operation in still air with water temperatures from +25 °C (+77 °F) up to +40 °C (+104 °F). Winding temperature measure up to +110 °C (+230 °F) over water.

4) Optional via F port (flushing port).

EPU-G SIZE 13

Liquid Cooling, S EPU 013 x D GP xx W

Motor Performance Curves

50 W

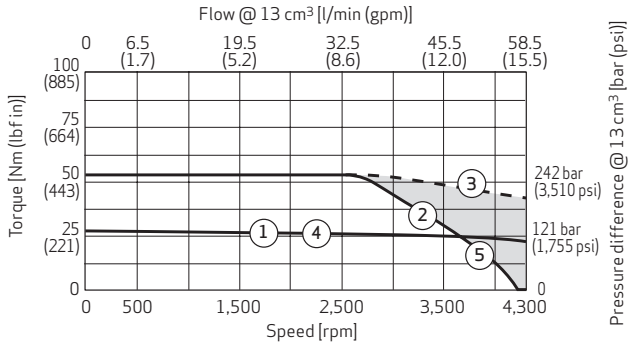

M0 W

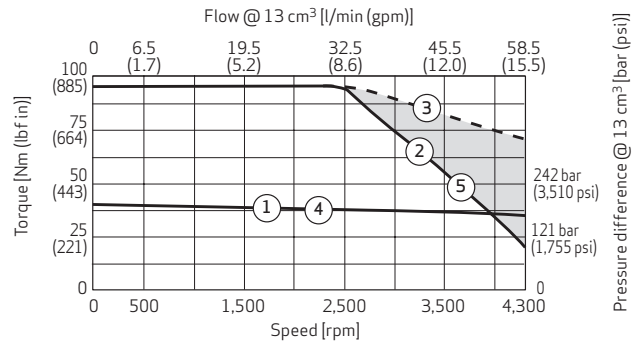

H0 W

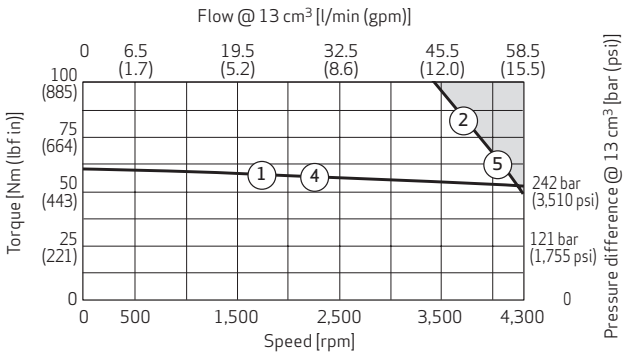

- ① Continuous torque at 110 K temperature difference over water, max. winding temperature 150 °C (302 °F)
- ② Maximum torque without field weakening
- ③ Maximum torque with field weakening
- ④ Continuous torque if recommended drive size is used
- ⑤ Maximum torque with field weakening if recommended drive size is used

Notes:

Motor performance with 565 V_{DC} link voltage

Motor performance does not take the pump efficiency into account

Motor performance determined with respective max. cooling water flow rate, see characteristic table

Pressure difference $\Delta p = p_A - p_B$

EPU-G SIZE 13

Liquid Cooling, S EPU 013 x D GP xx W

Installation Drawings

50 W

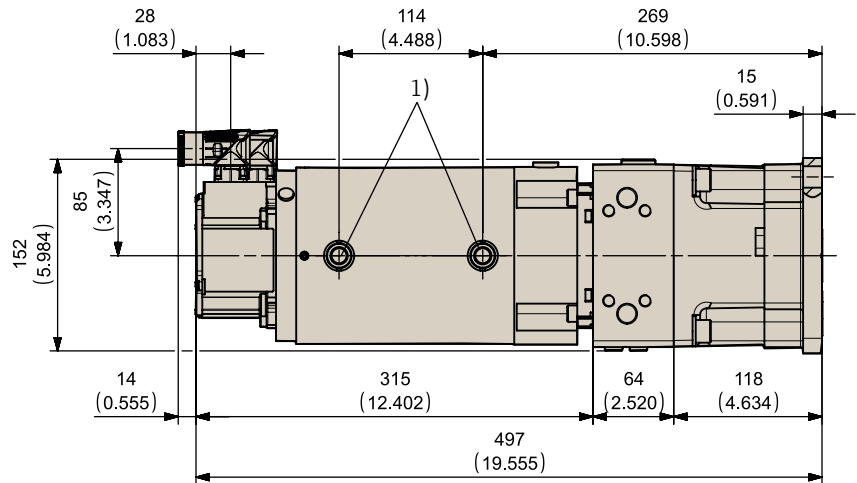

M0 W

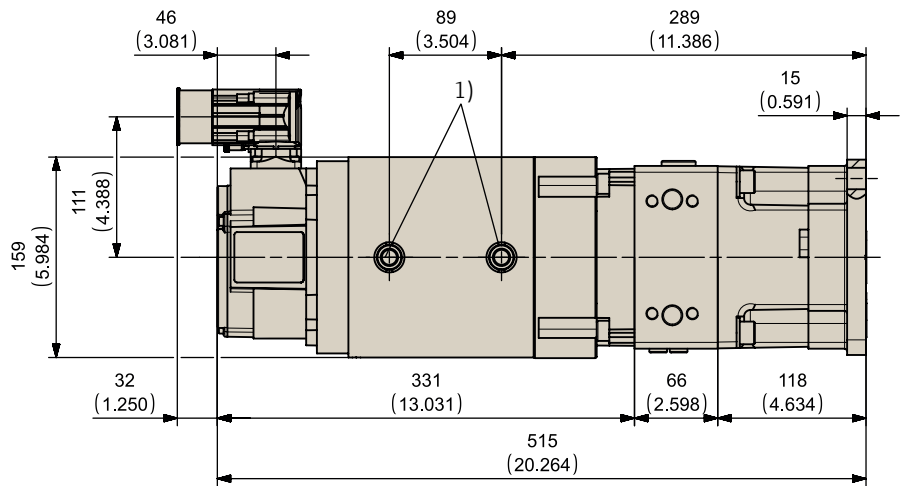

H0 W

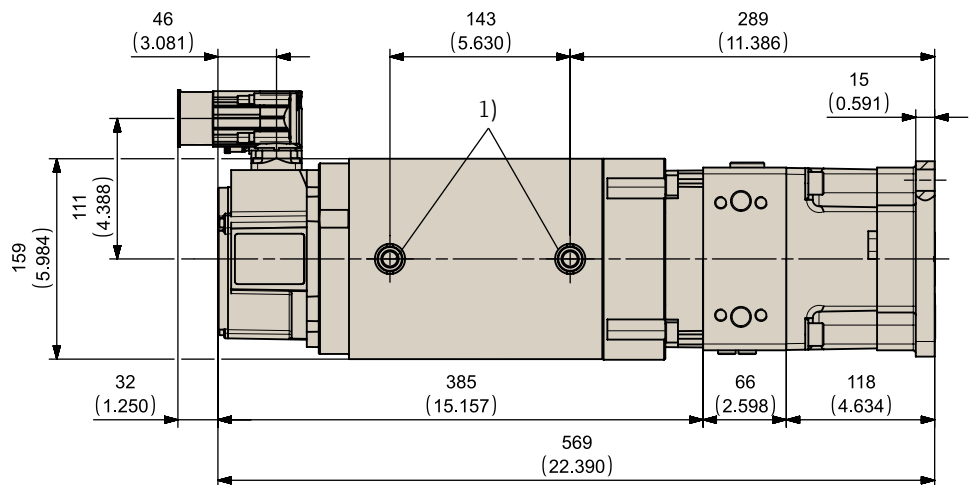

1) Cooler outlet G3/8" (thread depth max. 7 mm)

Note: Dimensions mm (inch)

EPU-G SIZE 20

Natural Cooling, S EPU 020 x D GP xx C

Characteristics Table

Performance class		Small	Medium	High
S EPU 020 x D GP		S0 C	M0 C	H0 C
Pump				
Displacement	V_{max}	20 cm ³ /rev (1.22 in ³ /rev)		
Maximum pump speed	n_{max}	4,000 rpm		
Maximum pump acceleration	\dot{n}_{max}	85,900 rpm/s		
Maximum housing pressure ¹⁾	p_{Lmax}, p_F	Refer to speed/pressure curve		
Maximum flow	Q_{max}	83 l/min (21.9 gpm)		
Maximum pressure ports A and B	p_A, p_B	345 bar (5,004 psi)		
Flushing flow rate ⁴⁾	Q_F	2 to 3 l/min (0.53 to 0.79 gpm)		
Motor				
Continuous stall torque ³⁾	M_0	39 Nm (345 lbf in)	77 Nm (682 lbf in)	124 Nm (1,097 lbf in)
Rated torque ³⁾	M_n	21 Nm (186 lbf in)	41 Nm (363 lbf in)	58 Nm (513 lbf in)
Maximum torque	M_{max}	225 Nm (1,991 lbf in)	267 Nm (2,363 lbf in)	448 Nm (3,965 lbf in)
Rated speed	n_n	2,100 rpm	1,200 rpm	1,000 rpm
Maximum speed	n_{max}	Maximum speed see $M = f(n)$ performance curve		
Continuous stall current	I_0	24.77 A _{rms}	48.74 A _{rms}	69.94 A _{rms}
Maximum current	I_{max}	158 A _{rms}	211 A _{rms}	317 A _{rms}
Torque constant	k_t	1.56 Nm/A _{rms} (13.8 lbf in/A _{rms})	1.59 Nm/A _{rms} (14.1 lbf in/A _{rms})	1.78 Nm/A _{rms} (15.8 lbf in/A _{rms})
Voltage constant	k_e	110.33 V _{rms} /1,000 rpm	105.89 V _{rms} /1,000 rpm	118.47 V _{rms} /1,000 rpm
Thermal time constant	t_{th}	4,333 s	2,550 s	3,300 s
Winding resistance at +25 °C	R_{tt}	0.287 Ω	0.121 Ω	0.076 Ω
Winding inductance	L_{tt}	2.515 mH	1.387 mH	0.978 mH
Power connector		Size 1.5 rotatable		
Feedback connector		Signal resolver connector rotatable		
Thermal sensor		NTC 220 kOhm, Pt1000		
EPU unit				
Inertia	J	48.48 kg cm ² (429 10 ⁻⁴ lbf in s ²)	264.29 kg cm ² (2,339 10 ⁻⁴ lbf in s ²)	431.29 kg cm ² (3,817 10 ⁻⁴ lbf in s ²)
Weight	m	57.8 kg (127.4 lb)	95.1 kg (209.7 lb)	127.1 kg (280.2 lb)
Tightening torque 4xM16x45 -10.9 cylinder head screw		310 Nm (2,744 lbf in)		
Servo drive				
Recommended drive size ²⁾		G392-045 size 5	G392-072 size 5	

- 1) See diagram "Housing Pressure (p_r)" on page 4.
- 2) See catalog "Modular Multi-Axis Servo Drive Systems (MSD)".
- 3) Operation in still air with ambient temperatures up to +40 °C (+104 °F). Winding temperature measure up to +110 °C (+230 °F) over ambient.
- 4) Optional via F port (flushing port).

EPU-G SIZE 20

Natural Cooling, S EPU 020 x D GP xx C

Motor Performance Curves

50 C

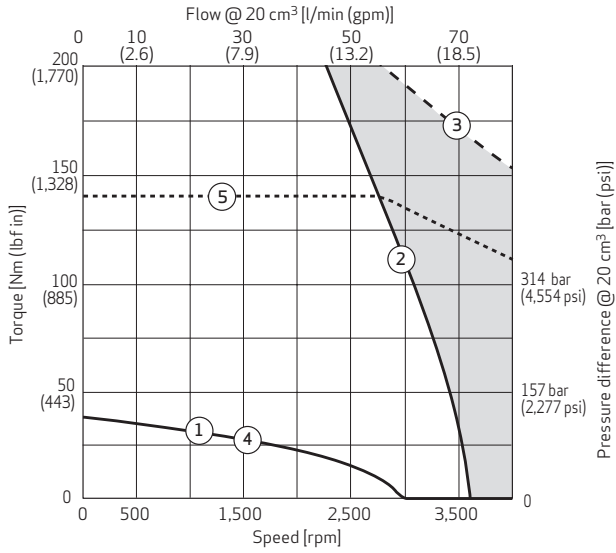

M0 C

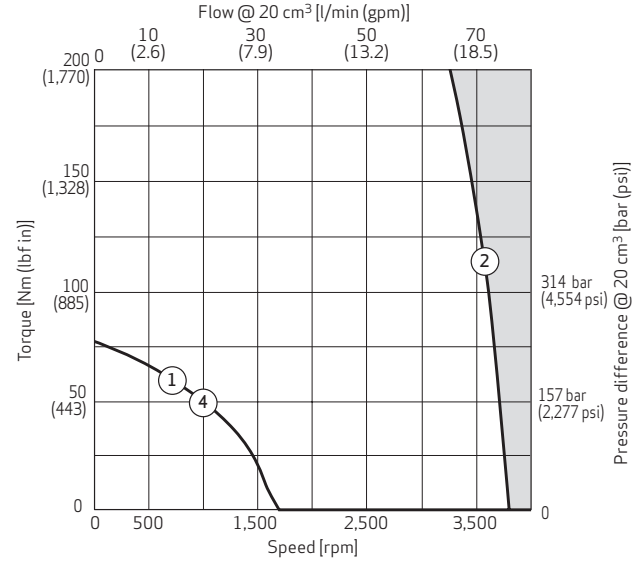

H0 C

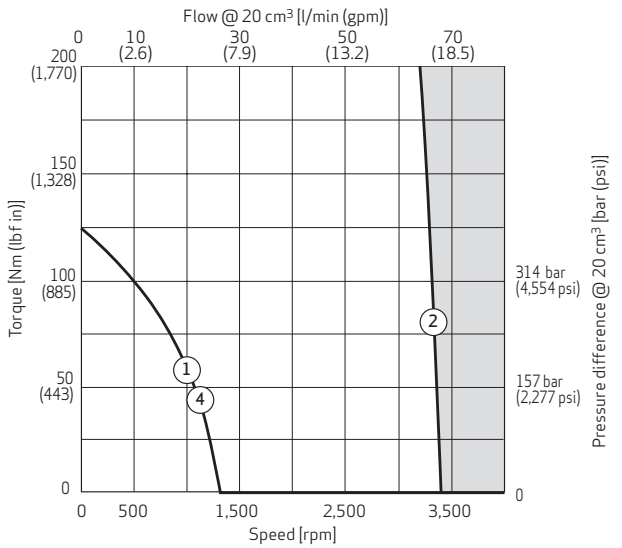

- ① Continuous torque at 110 K temperature difference over ambient, max. winding temperature 150 °C (302 °F)
- ② Maximum torque without field weakening
- ③ Maximum torque with field weakening
- ④ Continuous torque if recommended drive size is used
- ⑤ Maximum torque with field weakening if recommended drive size is used

Notes:

Motor performance with 565 V_{DC} link voltage

Motor performance does not take the pump efficiency into account

Pressure difference $\Delta p = p_A - p_B$

EPU-G SIZE 20

Natural Cooling, S EPU 020 x D GP xx C

Installation Drawings

S0 C

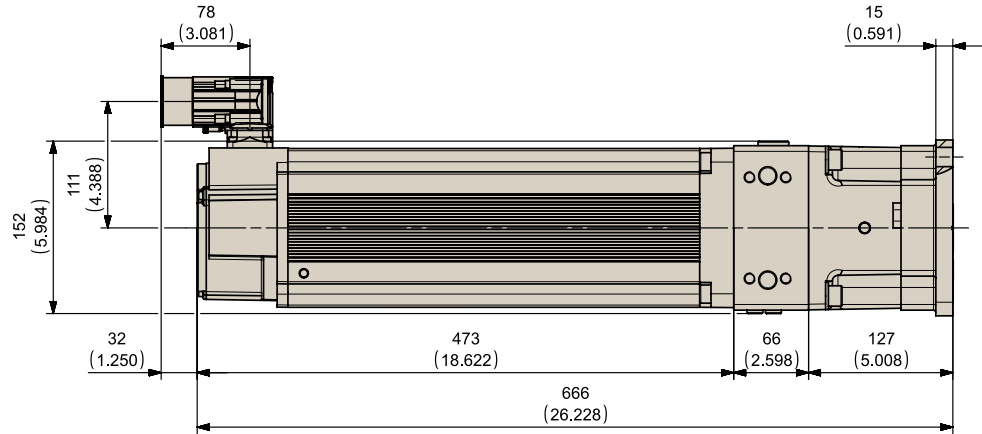

M0 C

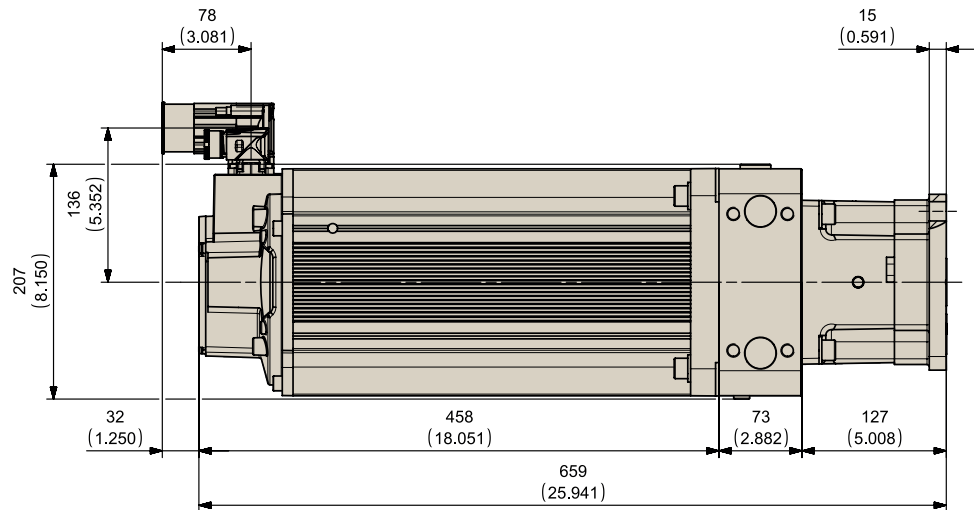

H0 C

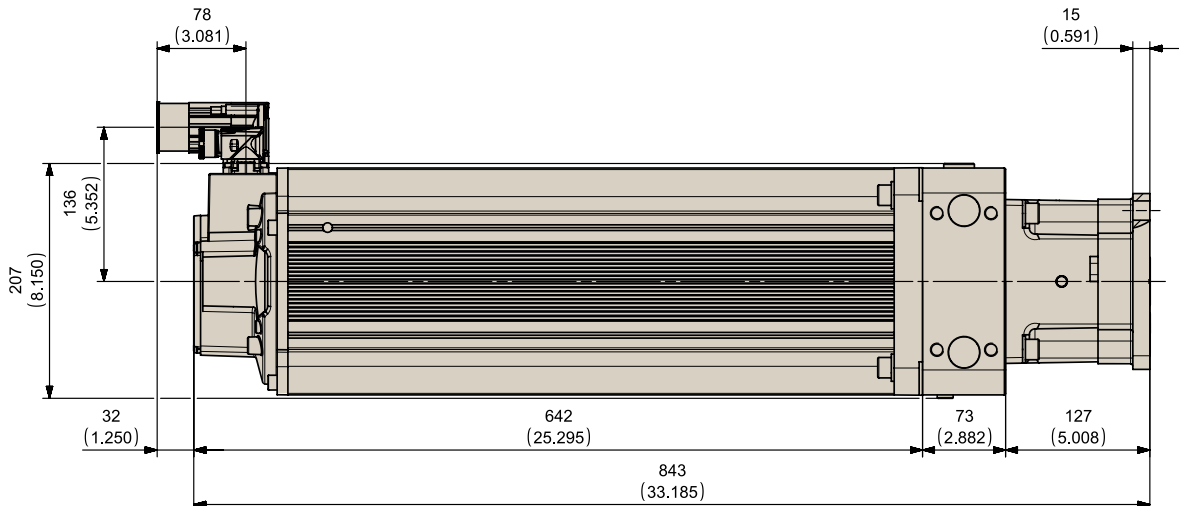

Note: Dimensions mm (inch)

EPU-G SIZE 20

Fan Cooling, S EPU 020 x D GP xx F

Characteristics Table

Performance class		Small	Medium	High
S EPU 020 x D GP		S0 F	M0 F	H0 F
Pump				
Displacement	V_{max}	20 cm ³ /rev (1.22 in ³ /rev)		
Maximum pump speed	n_{max}	4,000 rpm		
Maximum pump acceleration	\dot{n}_{max}	85,900 rpm/s		
Maximum housing pressure ¹⁾	$p_{L,max}, p_F$	Refer to speed/pressure curve		
Maximum flow	Q_{max}	83 l/min (21.9 gpm)		
Maximum pressure ports A and B	p_A, p_B	345 bar (5,004 psi)		
Flushing flow rate ⁴⁾	Q_F	2 to 3 l/min (0.53 to 0.79 gpm)		
Motor				
Continuous stall torque ³⁾	M_0	34 Nm (301 lbf in)	61 Nm (540 lbf in)	105 Nm (929 lbf in)
Rated torque ³⁾	M_n	24 Nm (212 lbf in)	40 Nm (354 lbf in)	45 Nm (398 lbf in)
Maximum torque	M_{max}	134 Nm (1,186 lbf in)	225 Nm (1,991 lbf in)	267 Nm (2,363 lbf in)
Rated speed	n_n	3,400 rpm	2,600 rpm	2,400 rpm
Maximum speed	n_{max}	Maximum speed see $M = f(n)$ performance curve		
Continuous stall current	I_0	28.81 A _{rms}	38.8 A _{rms}	66.83 A _{rms}
Maximum current	I_{max}	126 A _{rms}	158 A _{rms}	211 A _{rms}
Torque constant	k_t	1.17 Nm/A _{rms} (10.4 lbf in/A _{rms})	1.57 Nm/A _{rms} (13.9 lbf in/A _{rms})	1.57 Nm/A _{rms} (13.9 lbf in/A _{rms})
Voltage constant	k_e	82.93 V _{rms} /1,000 rpm	110.33 V _{rms} /1,000 rpm	105.89 V _{rms} /1,000 rpm
Thermal time constant	t_{th}	2,600 s	4,333 s	1,800 s
Winding resistance at +25 °C	R_{tt}	0.296 Ω	0.287 Ω	0.121 Ω
Winding inductance	L_{tt}	2.356 mH	2.501 mH	1.400 mH
Power connector		Size 1.5 rotatable		
Feedback connector		Signal resolver connector rotatable		
Fan connector		Size 1 rotatable		
Thermal sensor		NTC 220 kOhm, Pt1000		
EPU unit				
Inertia	J	31.69 kg cm ² (280 10 ⁻⁴ lbf in s ²)	48.48 kg cm ² (429 10 ⁻⁴ lbf in s ²)	264.29 kg cm ² (2,339 10 ⁻⁴ lbf in s ²)
Weight	m	50.7 kg (111.7 lb)	61.1 kg (134.7 lb)	99.5 kg (219.4 lb)
Tightening torque 4xM16x45 -10.9 cylinder head screw		310 Nm (2,744 lbf in)		
Servo drive				
Recommended drive size ²⁾		G392-045 size 5		G392-072 size 5

1) See diagram "Housing Pressure (p_r)" on page 4.

2) See catalog "Modular Multi-Axis Servo Drive Systems (MSD)".

3) Operation in still air with ambient temperatures up to +40 °C (+104 °F). Winding temperature measure up to +110 °C (+230 °F) over ambient.

4) Optional via F port (flushing port).

EPU-G SIZE 20

Fan Cooling, S EPU 020 x D GP xx F

Motor Performance Curves

S0 F

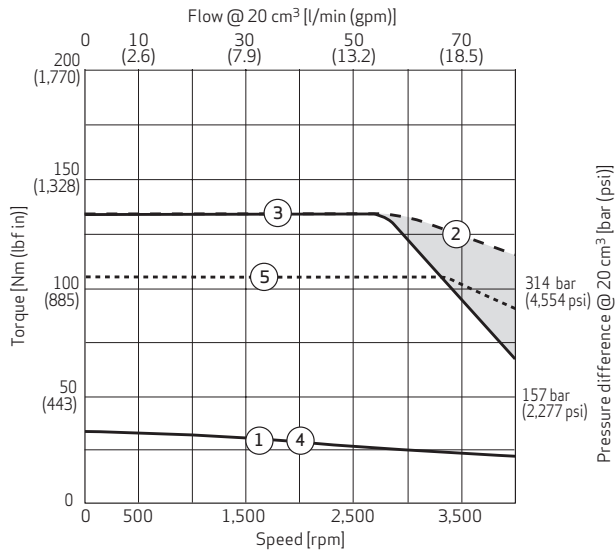

M0 F

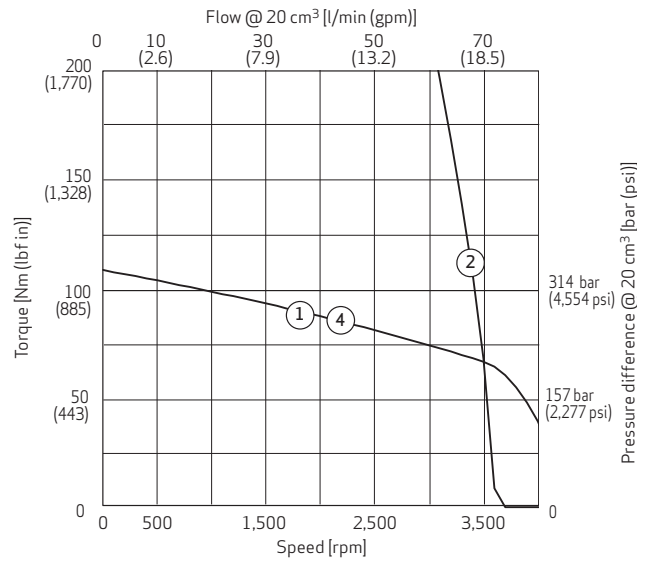

H0 F

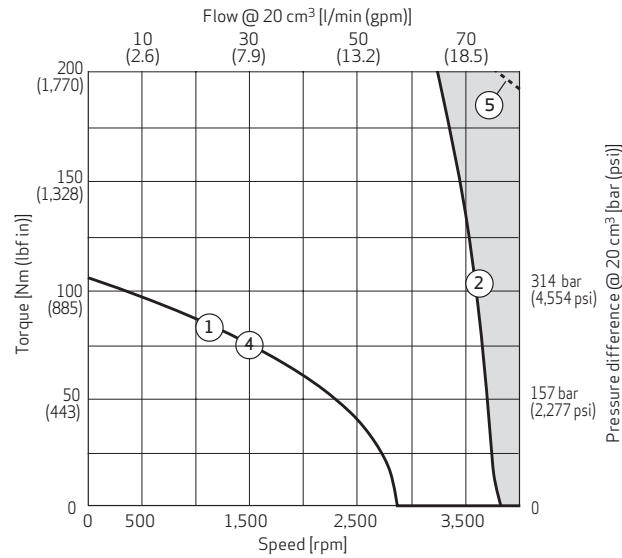

- ① Continuous torque at 110 K temperature difference over ambient, max. winding temperature 150 °C (302 °F)
- ② Maximum torque without field weakening
- ③ Maximum torque with field weakening
- ④ Continuous torque if recommended drive size is used
- ⑤ Maximum torque with field weakening if recommended drive size is used

Notes:

Motor performance with 565 V_{DC} link voltage

Motor performance does not take the pump efficiency into account

Pressure difference $\Delta p = p_A - p_B$

EPU-G SIZE 20

Fan Cooling, S EPU 020 x D GP xx F

Installation Drawings

S0 F

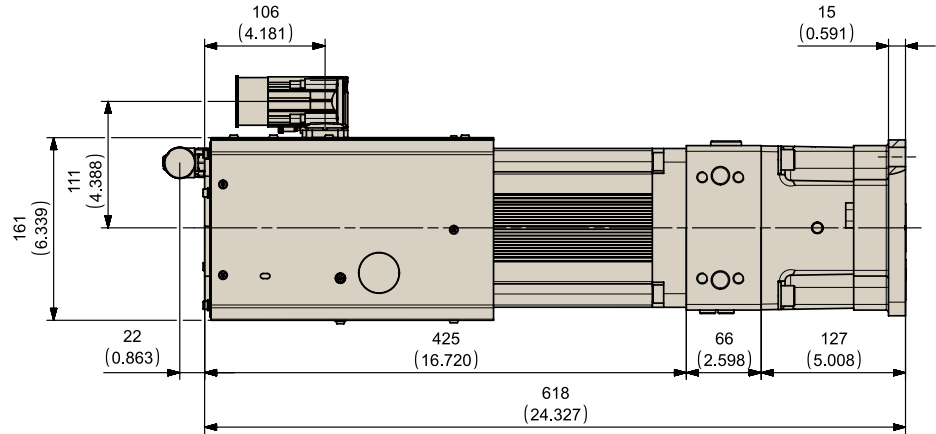

M0 F

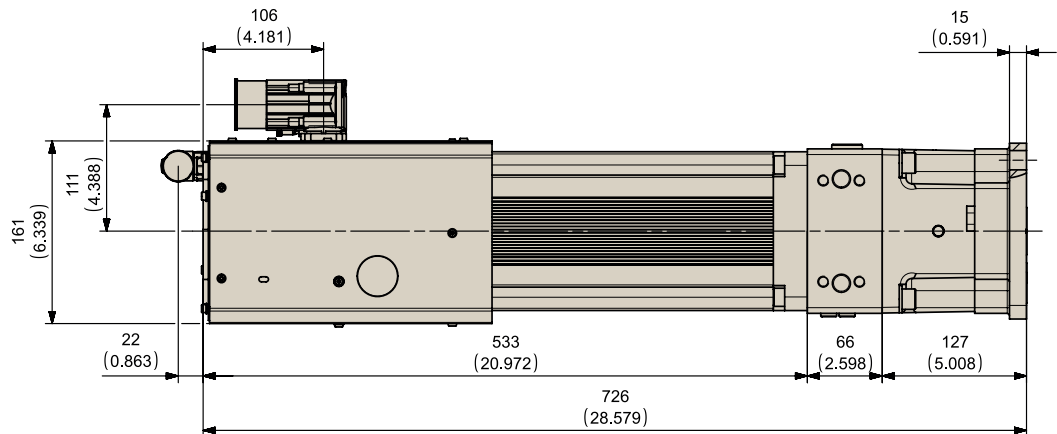

H0 F

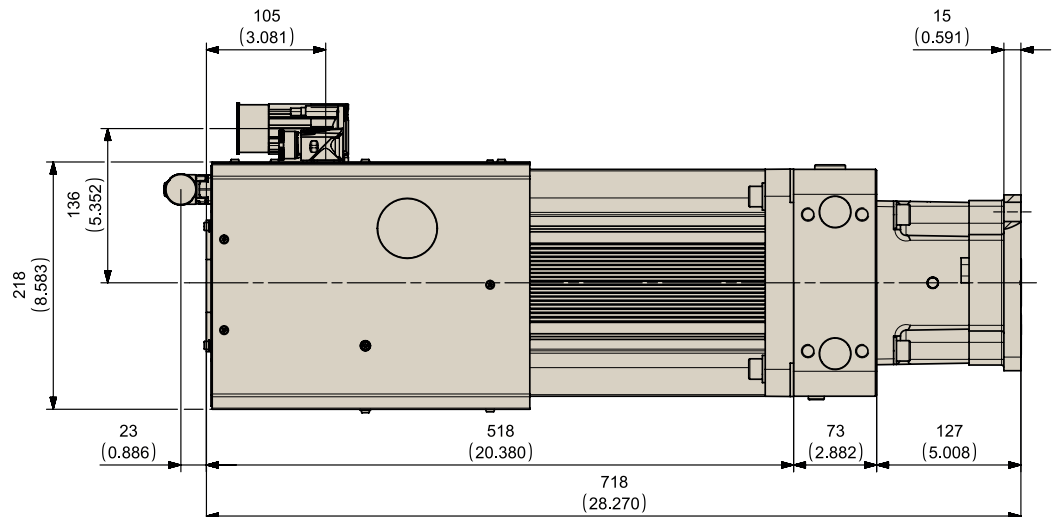

Note: Dimensions mm (inch)

EPU-G SIZE 20

Liquid Cooling, S EPU 020 x D GP xx W

Characteristics Table

Performance class		Small	Medium	High
S EPU 020 x D GP		S0W	M0W	H0W
Pump				
Displacement	V_{max}	20 cm ³ /rev (1.22 in ³ /rev)		
Maximum pump speed	n_{max}	4,000 rpm		
Maximum pump acceleration	\dot{n}_{max}	85,900 rpm/s		
Maximum housing pressure ¹⁾	p_{Lmax}, p_F	Refer to speed/pressure curve		
Maximum flow	Q_{max}	83 l/min (21.9 gpm)		
Maximum pressure ports A and B	p_A, p_B	345 bar (5,004 psi)		
Flushing flow rate ⁴⁾	Q_F	2 to 3 l/min (0.53 to 0.79 gpm)		
Motor				
Continuous stall torque ³⁾	M_0	40 Nm (354 lbf in)	60 Nm (531 lbf in)	99 Nm (876 lbf in)
Rated torque ³⁾	M_n	37 Nm (327 lbf in)	54 Nm (478 lbf in)	90 Nm (797 lbf in)
Maximum torque	M_{max}	95 Nm (841 lbf in)	135 Nm (1,195 lbf in)	225 Nm (1,991 lbf in)
Rated speed	n_n	3,000 rpm	3,400 rpm	3,000 rpm
Maximum speed	n_{max}	Maximum speed see $M = f(n)$ performance curve		
Continuous stall current	I_0	31.9 A _{rms}	51.08 A _{rms}	63.06 A _{rms}
Maximum current	I_{max}	85 A _{rms}	126 A _{rms}	158 A _{rms}
Torque constant	k_t	1.24 Nm/A _{rms} (11.0 lbf in/A _{rms})	1.17 Nm/A _{rms} (10.4 lbf in/A _{rms})	1.57 Nm/A _{rms} (13.9 lbf in/A _{rms})
Voltage constant	k_e	88.12 V _{rms} /1,000 rpm	82.93 V _{rms} /1,000 rpm	110.33 V _{rms} /1,000 rpm
Thermal time constant	t_{th}	234 s	353 s	588 s
Winding resistance at +25 °C	R_{tt}	0.576 Ω	0.296 Ω	0.287 Ω
Winding inductance	L_{tt}	3.972 mH	2.357 mH	2.501 mH
Power connector		Size 1.5 rotatable		
Feedback connector		Signal resolver connector rotatable		
Thermal sensor		NTC 220 kΩ, Pt1000		
Cooling water flow rate	Q_w	8 l/min (2.1 gpm)		
EPU unit				
Inertia	J	23.3 kg cm ² (206 10 ⁻⁴ lbf in s ²)	31.7 kg cm ² (280 10 ⁻⁴ lbf in s ²)	48.5 kg cm ² (429 10 ⁻⁴ lbf in s ²)
Weight	m	44.6 kg (98.3 lb)	50.1 kg (110.5 lb)	63.4 kg (139.8 lb)
Tightening torque 4xM16x45 -10.9 cylinder head screw		310 Nm (2,744 lbf in)		
Servo drive				
Recommended drive size ²⁾		G392-045 size 5	G392-060 size 5	G392-072 size 5

1) See diagram "Housing Pressure (p_r)" on page 4.

2) See catalog "Modular Multi-Axis Servo Drive Systems (MSD)".

3) Operation in still air with water temperatures from +25 °C (+77 °F) up to +40 °C (+104 °F). Winding temperature measure up to +110 °C (+230 °F) over water.

4) Optional via F port (flushing port).

EPU-G SIZE 20

Liquid Cooling, S EPU 020 x D GP xx W

Motor Performance Curves

50 W

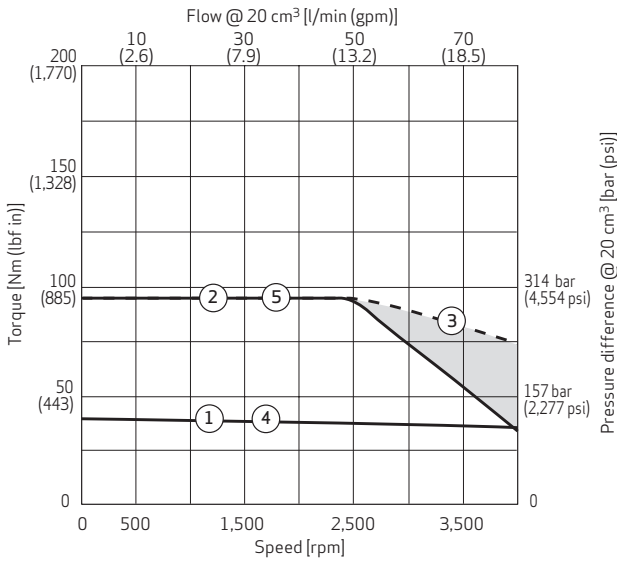

M0 W

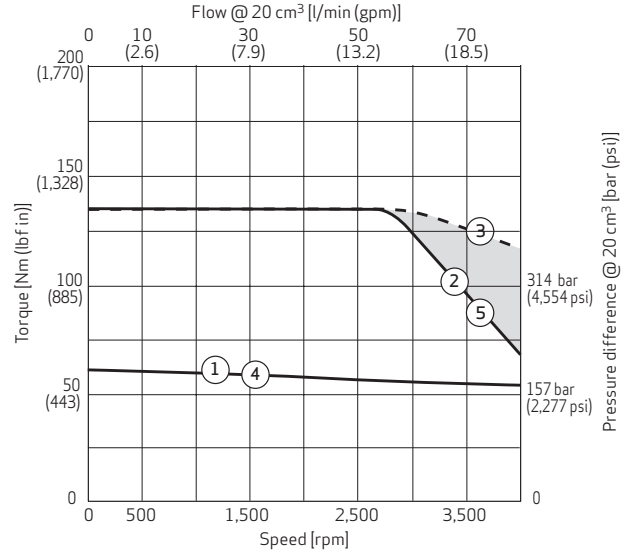

H0 W

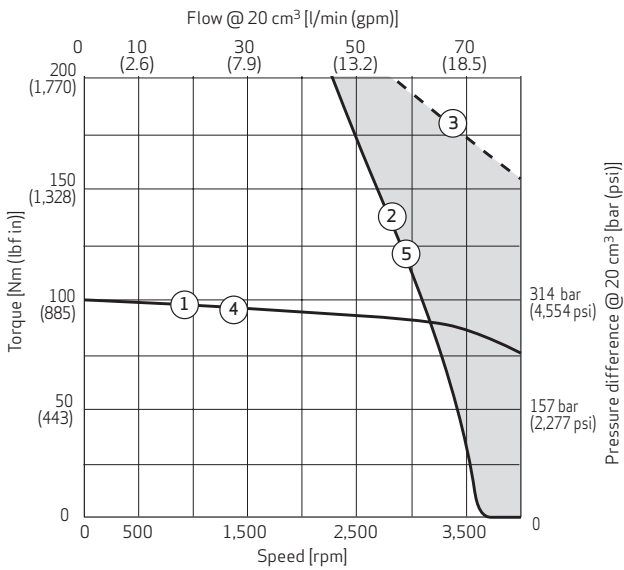

- ① Continuous torque at 110 K temperature difference over water, max. winding temperature 150 °C (302 °F)
- ② Maximum torque without field weakening
- ③ Maximum torque with field weakening
- ④ Continuous torque if recommended drive size is used
- ⑤ Maximum torque with field weakening if recommended drive size is used

Notes:

Motor performance with 565 V_{DC} link voltage

Motor performance does not take the pump efficiency into account

Motor performance determined with respective max. cooling water flow rate, see characteristic table

Pressure difference $\Delta p = p_A - p_B$

EPU-G SIZE 20

Liquid Cooling, S EPU 020 x D GP xx W

Installation Drawings

50 W

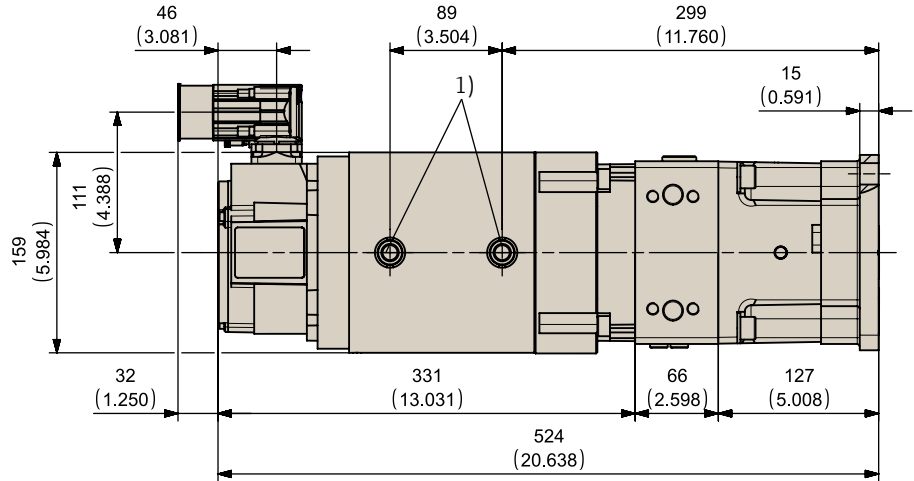

M0 W

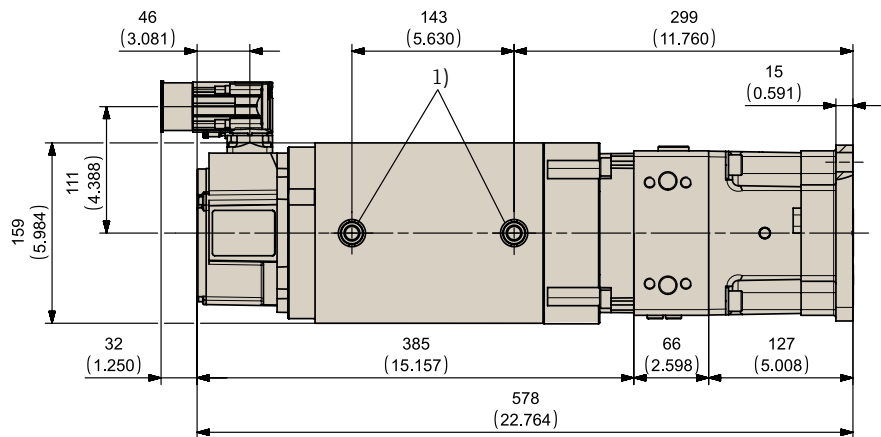

H0 W

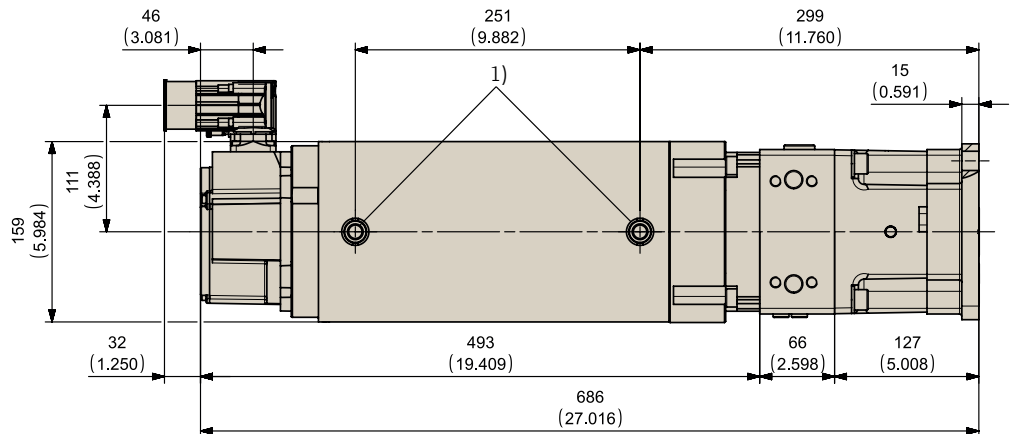

1) Cooler outlet G3/8" (thread depth max. 7 mm)

Note: Dimensions mm (inch)

EPU-G SIZE 13 AND 20 - MOUNTING PATTERN AND PUMP FRONT VIEW

Mounting Pattern and Pump Front View

Mounting Pattern

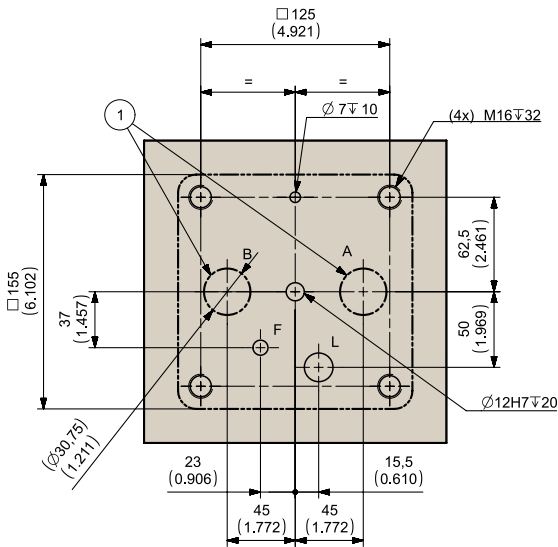

① Place holes inside marked circle

Port	d
A+B	15 to 26 mm
F	10 mm
L	19 mm

Pump Front View

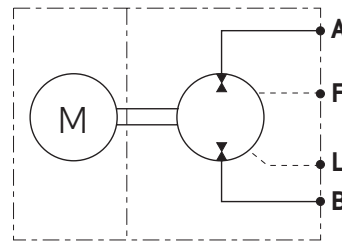
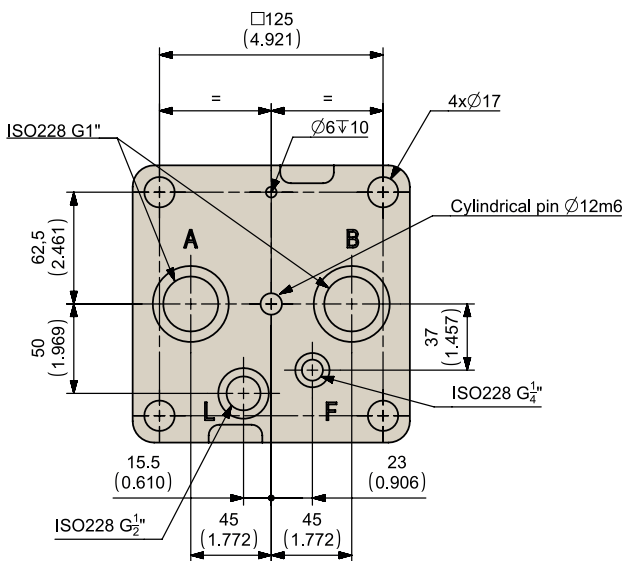

Port	Designation	Pressure [bar (psi)]	Port dimension in counter surface	
			Minimum Ø [mm (in)]	Maximum Ø [mm (in)]
A, B	Operating ports	345 bar (5,004 psi)	15 (0.59)	26 (1.02)
F	Flushing port	See diagram on page 4	10 (0.39)	
L	Leakage port		19 (0.75)	

EPU SIZE 19

Natural Cooling, S EPU 019 A D xx xx C

Characteristics Table

Performance class		Small	Medium	High
S EPU 019 A D xx		S0 C	M0 C	H0 C
Pump				
Displacement	V_{max}	19 cm ³ /rev (1.16 in ³ /rev)		
Maximum pump speed at 3.6 bar (abs)	n_{max}	4,500 rpm		
Maximum pump acceleration	\dot{n}_{max}	112,500 rpm/s		
Maximum housing pressure ¹⁾	p_{Lmax}, p_{Sp}	10 bar (145 psi)		
Maximum flow	Q_{max}	85 l/min (22.5 gpm)		
Maximum pressure ports A and B	p_A, p_B	350 bar (5,076 psi)		
Flushing flow rate ⁴⁾	Q_{Sp}	2 to 3 l/min (0.5 to 0.8 gpm)		
Motor				
Continuous stall torque ³⁾	M_0	40 Nm (354 lbf in)	93 Nm (823 lbf in)	137 Nm (1,213 lbf in)
Rated torque ³⁾	M_n	22 Nm (195 lbf in)	45 Nm (398 lbf in)	52 Nm (460 lbf in)
Maximum torque	M_{max}	141 Nm (1,248 lbf in)	391 Nm (3,461 lbf in)	595 Nm (5,266 lbf in)
Rated speed	n_n	3,000 rpm	2,500 rpm	
Maximum speed	n_{max}	Maximum speed see $M = f(n)$ performance curve		
Continuous stall current	I_0	23.08 A _{rms}	52.61 A _{rms}	69.17 A _{rms}
Maximum current	I_{max}	101 A _{rms}	250 A _{rms}	340.5 A _{rms}
Torque constant	k_t	1.72 Nm/A _{rms} (15.2 lbf in/A _{rms})	1.77 Nm/A _{rms} (15.7 lbf in/A _{rms})	1.98 Nm/A _{rms} (17.5 lbf in/A _{rms})
Voltage constant	k_e	103.67 V _{rms} /1,000 _{rpm}	106.63 V _{rms} /1,000 _{rpm}	119.96 V _{rms} /1,000 _{rpm}
Thermal time constant	t_{th}	3,882 s	4,200 s	5,200 s
Winding resistance at +25 °C	R_{tt}	0.351 Ω	0.096 Ω	0.074 Ω
Winding inductance	L_{tt}	4.254 mH	1.719 mH	1.433 mH
Power connector		Size 1 rotatable	Size 1.5 rotatable	
Feedback connector		Signal resolver connector rotatable		
Thermal sensor		NTC 220 kOhm, Pt1000		
EPU unit				
Inertia	J	38 kg cm ² (336 10 ⁻⁴ lbf in s ²)	121.52 kg cm ² (1,076 10 ⁻⁴ lbf in s ²)	172.37 kg cm ² (1,526 10 ⁻⁴ lbf in s ²)
Weight	m	50.1 kg (110.3 lb)	82.7 kg (182.2 lb)	105.4 kg (232.4 lb)
Tightening torque 8x M12x45 -12.9 cylinder head screw		120 Nm + 10 Nm (1,062 lbf in + 89 lbf in)		
Servo drive				
Recommended drive size ²⁾		G392-024 size 4	G392-032 size 4	G392-045 size 5

1) See diagram "Maximum housing pressure $p_{Lmax}, p_{Sp} = f(n)$ " and "Installation note" on page 5.

2) See catalog "Modular Multi-Axis Servo Drive Systems (MSD)".

3) Operation in still air with ambient temperatures up to +40 °C (+104 °F). Winding temperature measure up to +110 °C (+230 °F) over ambient.

4) Optional via Sp port (flushing port).

EPU SIZE 19

Natural Cooling, S EPU 019 A D xx xx C

Motor Performance Curves

50 C

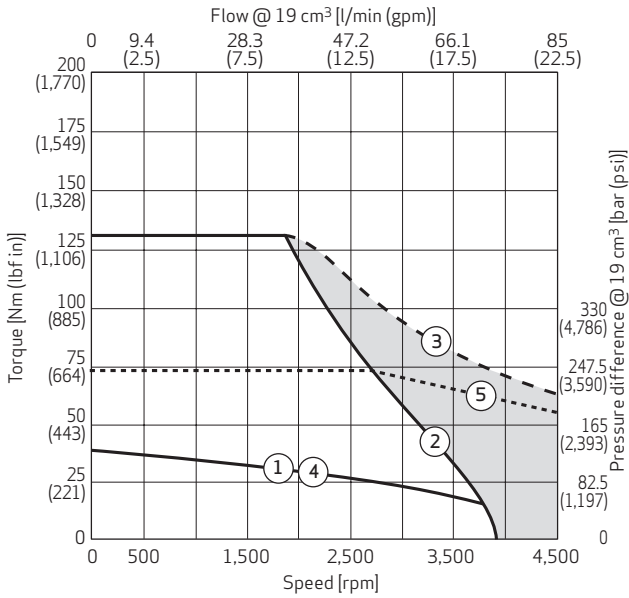

M0 C

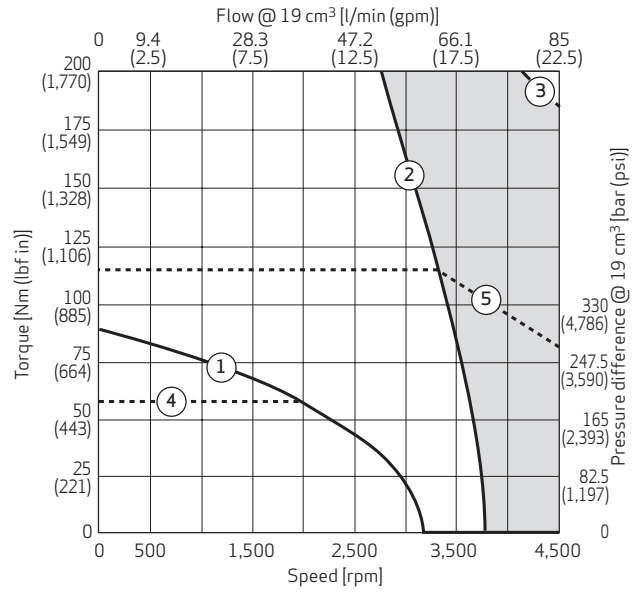

H0 C

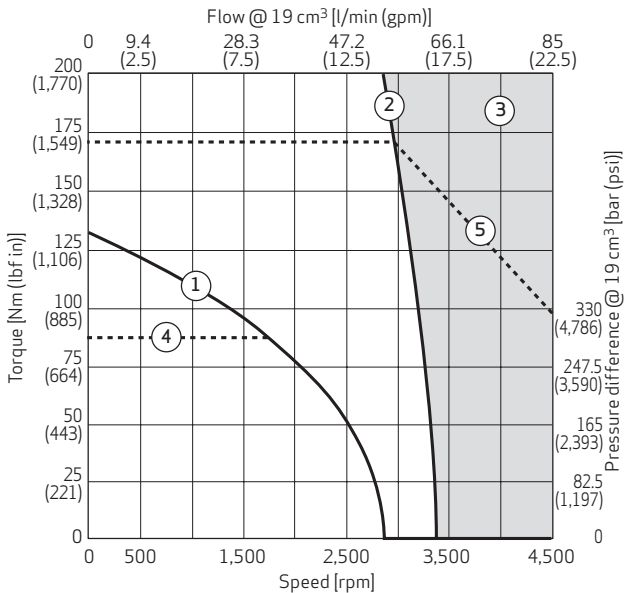

- ① Continuous torque at 110 K temperature difference over ambient, max. winding temperature 150 °C (302 °F)
- ② Maximum torque without field weakening
- ③ Maximum torque with field weakening
- ④ Continuous torque if recommended drive size is used
- ⑤ Maximum torque with field weakening if recommended drive size is used

Notes:

Motor performance with 565 V_{DC} link voltage

Motor performance does not take the pump efficiency into account

Pressure difference $\Delta p = p_A - p_B$

EPU SIZE 19

Natural Cooling, S EPU 019 A D xx xx C

Installation Drawings

S0 C

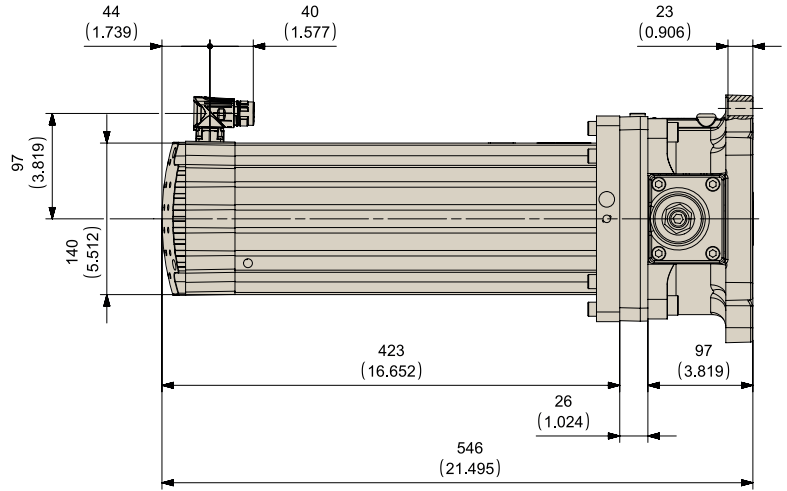

M0 C

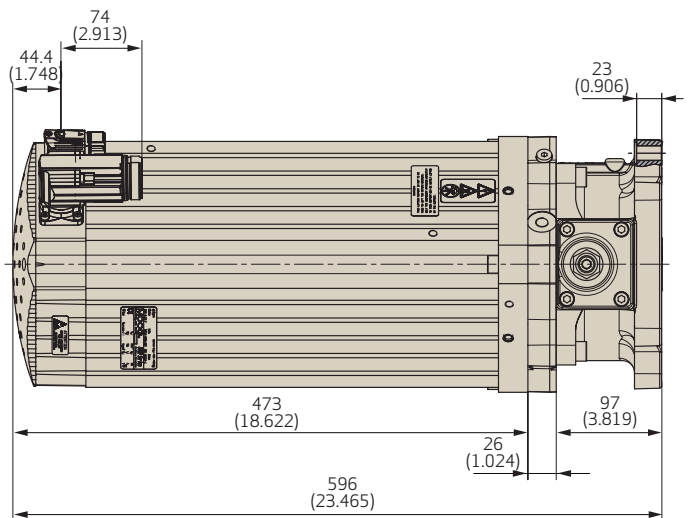

H0 C

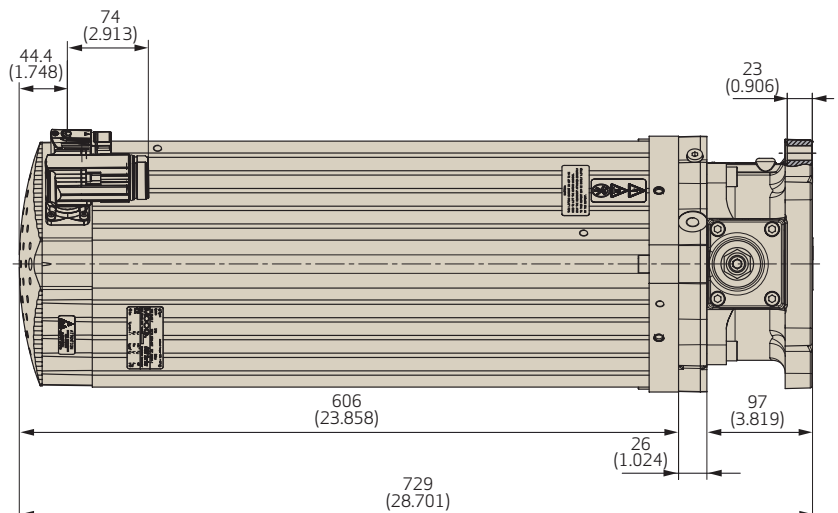

Note: Dimensions mm (inch)

EPU SIZE 19

Fan Cooling, S EPU 019 A D xx xx F

Characteristics Table

Performance class		Small	Medium	High
S EPU 019 A D xx		S0 F	M0 F	H0 F
Pump				
Displacement	V_{max}	19 cm ³ /rev (1.16 in ³ /rev)		
Maximum pump speed at 3.6 bar (abs)	n_{max}	4,500 rpm		
Maximum pump acceleration	\dot{n}_{max}	112,500 rpm/s		
Maximum housing pressure ¹⁾	p_{Lmax}, p_{Sp}	10 bar (145 psi)		
Maximum flow	Q_{max}	85 l/min (22.5 gpm)		
Maximum pressure ports A and B	p_A, p_B	350 bar (5,076 psi)		
Flushing flow rate ⁴⁾	Q_{Sp}	2 to 3 l/min (0.5 to 0.8 gpm)		
Motor				
Continuous stall torque ³⁾	M_0	33.5 Nm (296 lbf in)	47.5 Nm (420 lbf in)	111.5 Nm (987 lbf in)
Rated torque ³⁾	M_n	25.8 Nm (228 lbf in)	34.2 Nm (398 lbf in)	76.7 Nm (678 lbf in)
Maximum torque	M_{max}	88 Nm (779 lbf in)	132 Nm (3,461 lbf in)	391 Nm (3,461 lbf in)
Rated speed	n_n	3,000 rpm	3,000 rpm	2,500 rpm
Maximum speed	n_{max}	Maximum speed see $M = f(n)$ performance curve		
Continuous stall current	I_0	25.62 A _{rms}	27.69 A _{rms}	69.21 A _{rms}
Maximum current	I_{max}	80 A _{rms}	92 A _{rms}	250 A _{rms}
Torque constant	k_t	1.31 Nm/A _{rms} (11.6 lbf in/A _{rms})	1.72 Nm/A _{rms} (15.2 lbf in/A _{rms})	1.76 Nm/A _{rms} (15.6 lbf in/A _{rms})
Voltage constant	k_e	78.71 V _{rms} /1,000 _{rpm}	103.30 V _{rms} /1,000 _{rpm}	106.63 V _{rms} /1,000 _{rpm}
Thermal time constant	t_{th}	3,400 s	3,882 s	4,200 s
Winding resistance at +25 °C	R_{tt}	0.326 Ω	0.351 Ω	0.096 Ω
Winding inductance	L_{tt}	3.843 mH	4.386 mH	1.721 mH
Power connector		Size 1 rotatable	Size 1.5 rotatable	
Feedback connector		Signal resolver connector rotatable		
Fan connector		Size 1 rotatable		
Thermal sensor		NTC 220 kOhm, Pt1000		
EPU unit				
Inertia	J	31.7 kg cm ² (281 10 ⁻⁴ lbf in s ²)	38 kg cm ² (336 10 ⁻⁴ lbf in s ²)	121.5 kg cm ² (1,076 10 ⁻⁴ lbf in s ²)
Weight	m	49.3 kg (108.7 lb)	56.1 kg (123.7 lb)	93.2 kg (205.5 lb)
Tightening torque 8x M12x45 -12.9 cylinder head screw		120 Nm + 10 Nm (1,062 lbf in + 89 lbf in)		
Servo drive				
Recommended drive size ²⁾		G392-032 size 4		G392-060 size 5

1) See diagram "Maximum housing pressure $p_{Lmax}, p_{Sp} = f(n)$ " and "Installation note" on page 5.

2) See catalog "Modular Multi-Axis Servo Drive Systems (MSD)".

3) Operation in still air with ambient temperatures up to +40 °C (+104 °F). Winding temperature measure up to +110 °C (+230 °F) over ambient.

4) Optional via Sp port (flushing port).

EPU SIZE 19

Fan Cooling, S EPU 019 A D xx xx F

Motor Performance Curves

S0 F

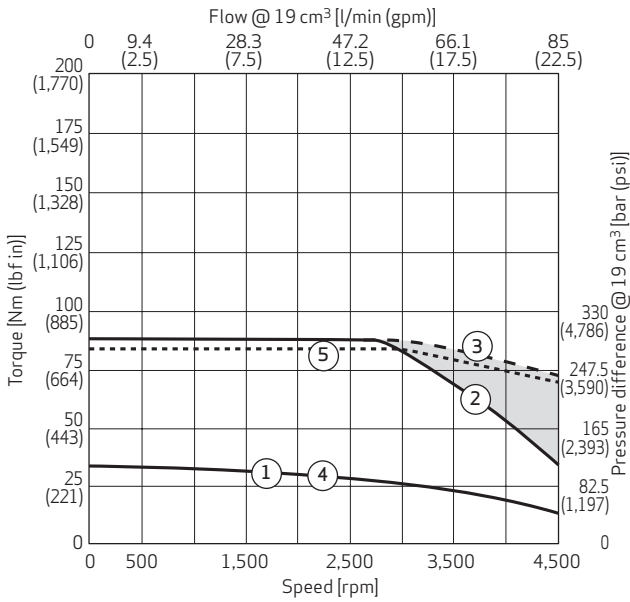

M0 F

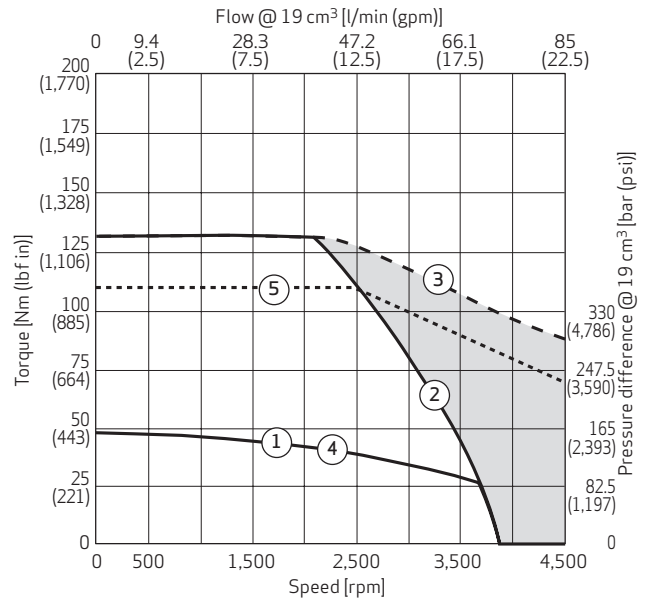

H0 F

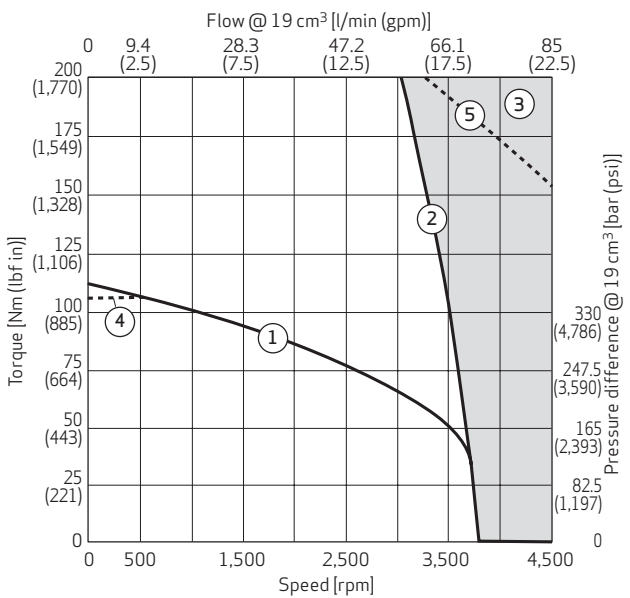

- ① Continuous torque at 110 K temperature difference over ambient, max. winding temperature 150 °C (302 °F)
- ② Maximum torque without field weakening
- ③ Maximum torque with field weakening
- ④ Continuous torque if recommended drive size is used
- ⑤ Maximum torque with field weakening if recommended drive size is used

Notes:

Motor performance with 565 V_{DC} link voltage

Motor performance does not take the pump efficiency into account

Pressure difference $\Delta p = p_A - p_B$

EPU SIZE 19

Fan Cooling, S EPU 019 A D xx xx F

Installation Drawings

S0 F

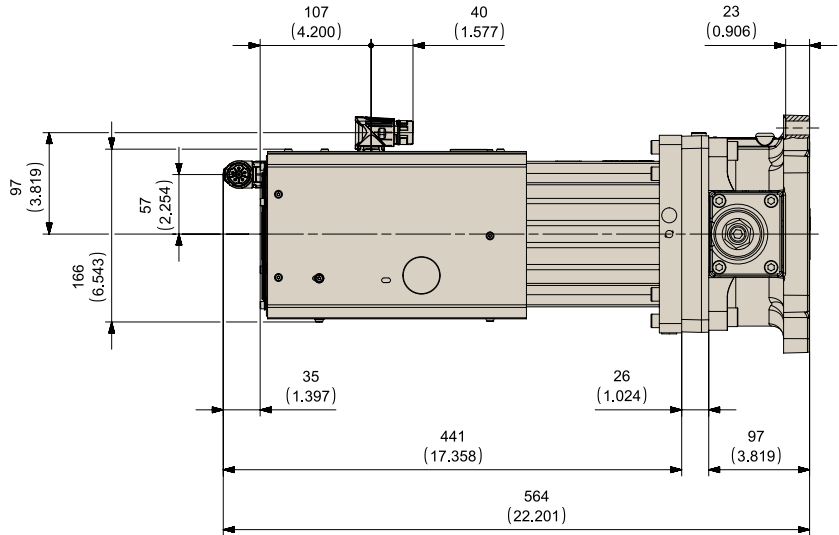

M0 F

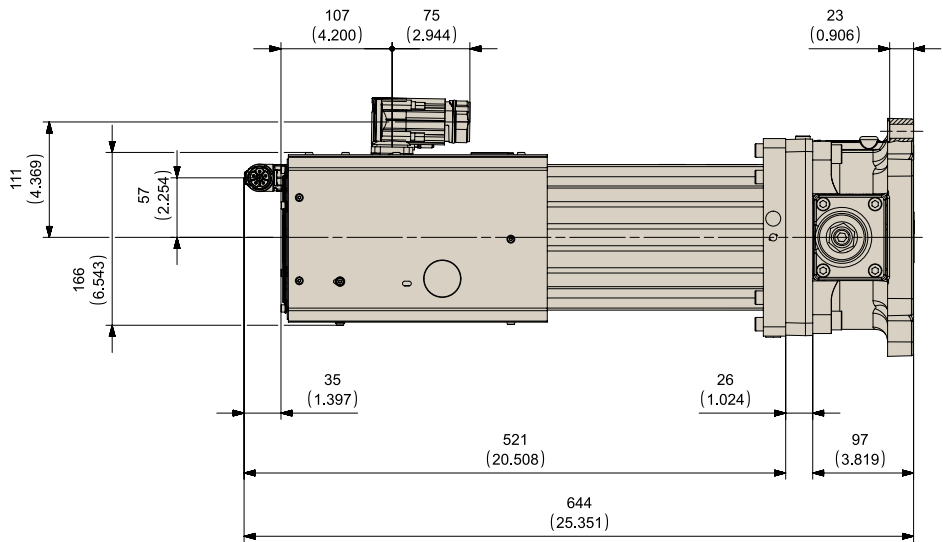

H0 F

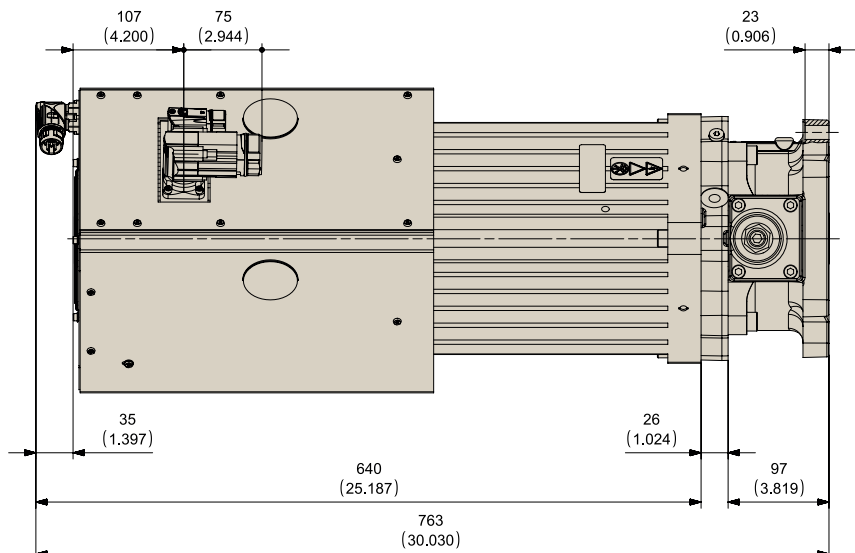

Note: Dimensions mm (inch)

EPU SIZE 19

Liquid Cooling, S EPU 019 A D xx xx W

Characteristics Table

Performance class		Medium	High
S EPU 019 A D xx		M0 W	H0 W
Pump			
Displacement	V_{max}	19 cm ³ /rev (1.16 in ³ /rev)	
Maximum pump speed at 3.6 bar (abs.)	n_{max}	4,500 rpm	
Maximum pump acceleration	\dot{n}_{max}	112,500 rpm/s	
Maximum housing pressure ¹⁾	p_{Lmax}, p_{Sp}	10 bar (145 psi)	
Maximum flow	Q_{max}	85 l/min (22.5 gpm)	
Maximum pressure ports A and B	p_A, p_B	350 bar (5,076 psi)	
Flushing flow rate ⁴⁾	Q_{Sp}	2 to 3 l/min (0.5 to 0.8 gpm)	
Motor			
Continuous stall torque ³⁾	M_0	62 Nm (549 lbf in)	91 Nm (805 lbf in)
Rated torque ³⁾	M_n	58 Nm (513 lbf in)	85 Nm (752 lbf in)
Maximum torque	M_{max}	94 Nm (832 lbf in)	140 Nm (1,239 lbf in)
Rated speed	n_n	3,000 rpm	
Maximum speed	n_{max}	Maximum speed see $M = f(n)$ performance curve	
Continuous stall current	I_0	48.45 A _{rms}	54.22 A _{rms}
Maximum current	I_{max}	88 A _{rms}	100 A _{rms}
Torque constant	k_t	1.27 Nm/A _{rms} (11.2 lbf in/A _{rms})	1.68 Nm/A _{rms} (14.9 lbf in/A _{rms})
Voltage constant	k_e	78.49 V _{rms} /1,000 _{rpm}	103.67 V _{rms} /1,000 _{rpm}
Thermal time constant	t_{th}	460 s	525 s
Winding resistance at +25 °C	R_{tt}	0.319 Ω	0.345 Ω
Winding inductance	L_{tt}	3.551 mH	4.047 mH
Power connector		Size 1.5 rotatable	
Feedback connector		Signal resolver connector rotatable	
Thermal sensor		NTC 220 kOhm, Pt1000	
Cooling water flow rate	Q_W	3 to 5 l/min (0.8 to 1.3 gpm)	
EPU unit			
Inertia	J	31.7 kg cm ² (281 10 ⁻⁴ lbf in s ²)	37.9 kg cm ² (335 10 ⁻⁴ lbf in s ²)
Weight	m	47.5 kg (104.7 lb)	56.3 kg (124.1 lb)
Tightening torque 8x M12x45 -12.9 cylinder head screw		120 Nm + 10 Nm (1,062 lbf in + 89 lbf in)	
Servo drive			
Recommended drive size ²⁾		G392-045 size 5	G392-060 size 5

1) See diagram "Maximum housing pressure $p_{Lmax}, p_{Sp} = f(n)$ " and "Installation note" on page 5.

2) See catalog "Modular Multi-Axis Servo Drive Systems (MSD)".

3) Operation in still air with water temperatures from +25 °C (+77 °F) up to +40 °C (+104 °F). Winding temperature measure up to +110 °C (+230 °F) over water.

4) Optional via Sp port (flushing port).

EPU SIZE 19

Liquid Cooling, S EPU 019 A D xx xx W

Motor Performance Curves

M0 W

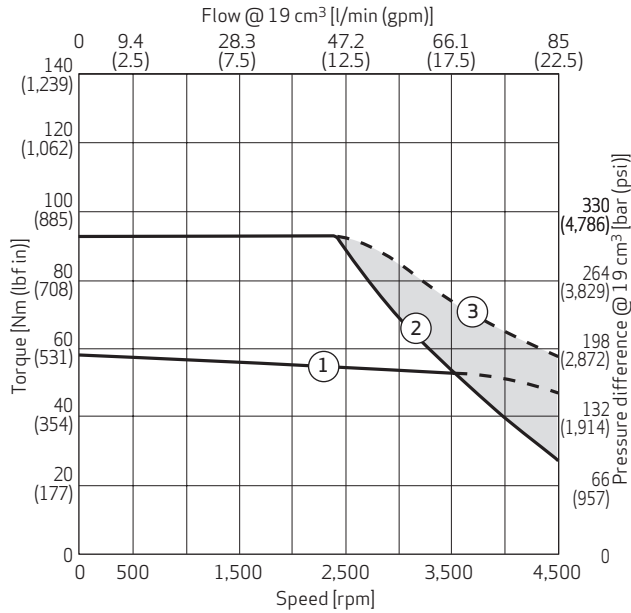

H0 W

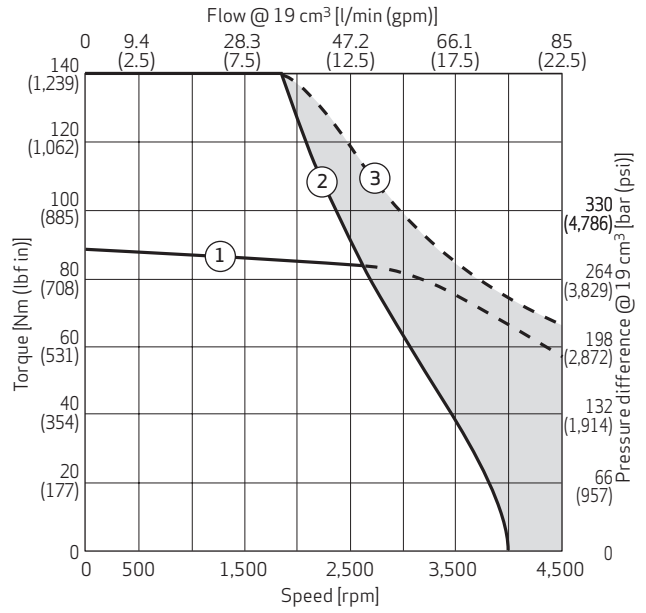

- ① Continuous torque at 110 K temperature difference over water, max. winding temperature 150 °C (302 °F)
- ② Maximum torque without field weakening
- ③ Maximum torque with field weakening

Notes:

Motor performance with 565 V_{DC} link voltage

Motor performance does not take the pump efficiency into account

Pressure difference $\Delta p = p_A - p_B$

Motor performance determined with respective max. cooling water flow rate, see characteristic table

EPU SIZE 19

Liquid Cooling, S EPU 019 A D xx xx W

Installation Drawings

M0 W

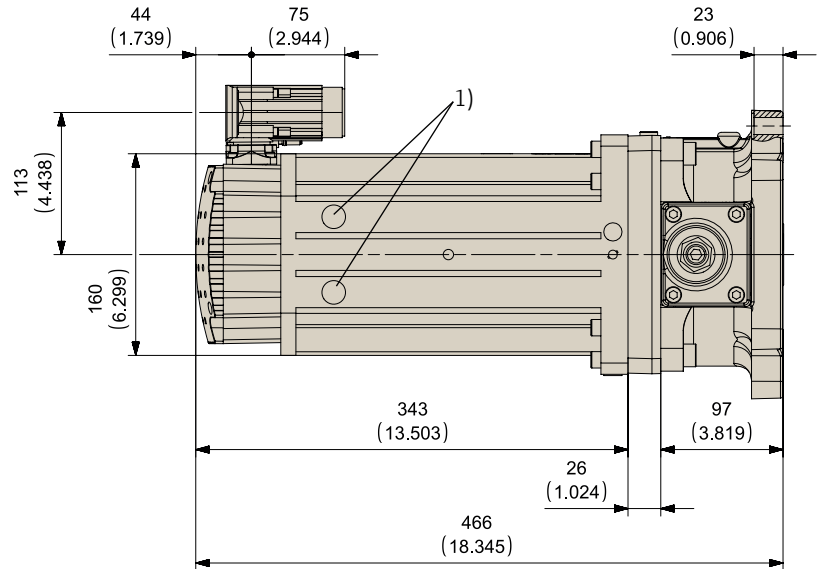

H0 W

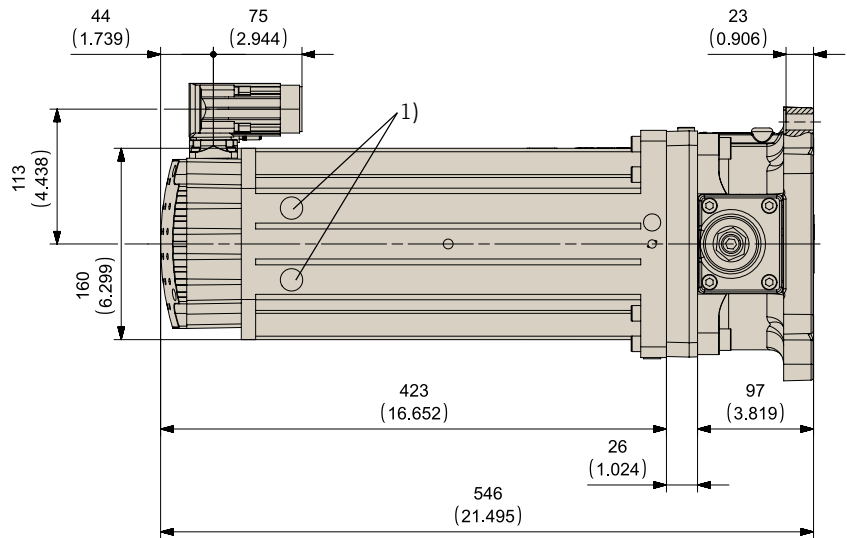

1) Cooler outlet G3/8" (thread depth max. 7 mm)

Note: Dimensions mm (inch)

EPU SIZE 19

Mounting Pattern and Pump Front View

Mounting Pattern

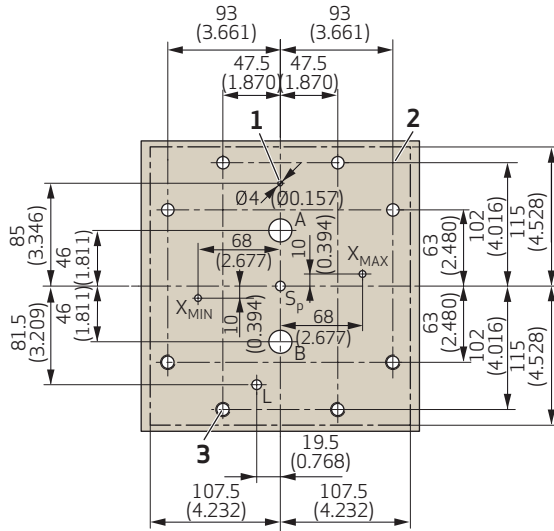

1. Use a spring-type pin with nominal diameter of 4 mm (0.16 in) (e.g. 4x12) according to ISO 13337
2. Area of
 - surface flatness: $\square 0.02$
 - surface roughness: $\sqrt{Rz4}$
3. M12, minimum 25 mm (0.98 in) deep.
Recommended: Use 8 cylinder head screws M12 (property class 12.9, minimum length 45 mm (1.8 in)) according to ISO 4762. Tightening torque 120 + 10 Nm (1,062 lbf in + 89 lbf in).

Note: Dimensions mm (inch)

Pump Front View

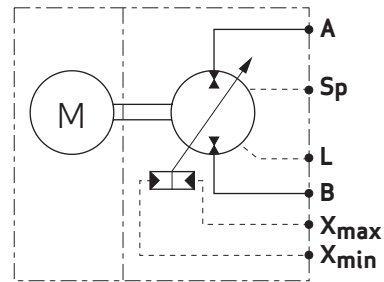
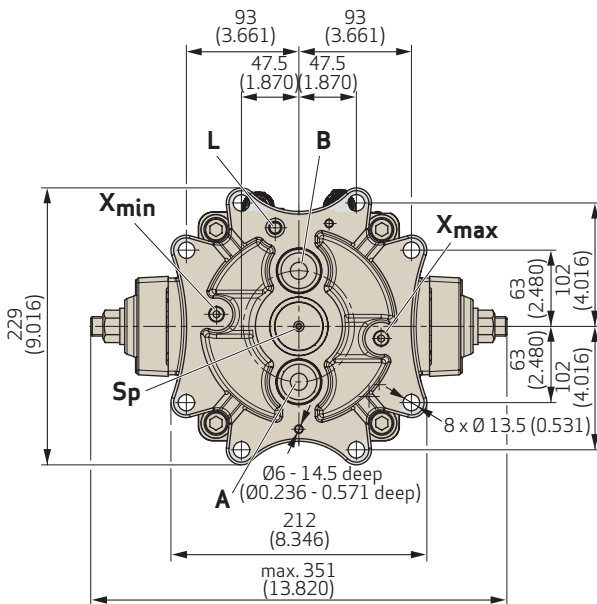

Port	Designation	Pressure [bar (psi)]	Port dimension in counter surface	
			Minimum Ø [mm (in)]	Maximum Ø [mm (in)]
A, B	Operating ports	350 (5,076)	14 (0.55)	20 (0.79)
Sp	Flushing port	10 (145)	5 (0.20)	15 (0.60)
L	Leakage port	10 (145)	8 (0.31)	9 (0.35)
X _{max}	Control port for maximum displacement (option N1 only)	350 (5,076)	5 (0.20)	5.5 (0.22)
X _{min}	Control port for minimum displacement (option N1 only)	350 (5,076)	5 (0.20)	5.5 (0.22)

EPU SIZE 32

Natural Cooling, S EPU 032 A D xx xx C

Characteristics Table

Performance class		Small	Medium
S EPU 032 A D xx		S0 C	M0 C
Pump			
Displacement	V_{max}	32 cm ³ /rev (1.95 in ³ /rev)	
Maximum pump speed at 2.7 bar (abs.)	n_{max}	3,700 rpm	
Maximum pump acceleration	\dot{n}_{max}	80,400 rpm/s	
Maximum housing pressure ¹⁾	p_{Lmax}, p_{Sp}	10 bar (145 psi)	
Maximum flow	Q_{max}	118 l/min (31.2 gpm)	
Maximum pressure ports A and B	p_A, p_B	350 bar (5,076 psi)	
Flushing flow rate ⁴⁾	Q_{Sp}	3 to 4 l/min (0.8 to 1.1 gpm)	
Motor			
Continuous stall torque ³⁾	M_0	93 Nm (823 lbf in)	137 Nm (1,213 lbf in)
Rated torque ³⁾	M_n	45 Nm (398 lbf in)	52 Nm (460 lbf in)
Maximum torque	M_{max}	391 Nm (3,461 lbf in)	595 Nm (5,266 lbf in)
Rated speed	n_n	2,500 rpm	
Maximum speed	n_{max}	Maximum speed see $M = f(n)$ performance curve	
Continuous stall current	I_0	52.61 A _{rms}	69.17 A _{rms}
Maximum current	I_{max}	250 A _{rms}	340.5 A _{rms}
Torque constant	k_t	1.77 Nm/A _{rms} (15.7 lbf in/A _{rms})	1.98 Nm/A _{rms} (17.5 lbf in/A _{rms})
Voltage constant	k_e	106.63 V _{rms} /1,000 _{rpm}	119.96 V _{rms} /1,000 _{rpm}
Thermal time constant	t_{th}	4,200 s	5,200 s
Winding resistance at +25 °C	R_{tt}	0.096 Ω	0.074 Ω
Winding inductance	L_{tt}	1.719 mH	1.433 mH
Power connector		Size 1.5 rotatable	
Feedback connector		Signal resolver connector rotatable	
Thermal sensor		NTC 220 kOhm, Pt1000	
EPU unit			
Inertia	J	164.8 kg cm ² (1,459 10 ⁻⁴ lbf in s ²)	215.7 kg cm ² (1,909 10 ⁻⁴ lbf in s ²)
Weight	m	100.3 kg (221.0 lb)	123 kg (271.2 lb)
Tightening torque 8x M12x45 -12.9 cylinder head screw		120 Nm + 10 Nm (1,062 lbf in + 89 lbf in)	
Servo drive			
Recommended drive size ²⁾		G392-045 size 5	

1) See diagram "Maximum housing pressure $p_{Lmax}, p_{Sp} = f(n)$ " and "Installation note" on page 5.

2) See catalog "Modular Multi-Axis Servo Drive Systems (MSD)".

3) Operation in still air with ambient temperatures up to +40 °C (+104 °F). Winding temperature measure up to +110 °C (+230 °F) over ambient.

4) Optional via Sp port (flushing port).

EPU SIZE 32

Natural Cooling, S EPU 032 A D xx xx C

Motor Performance Curves

50 C

M0 C

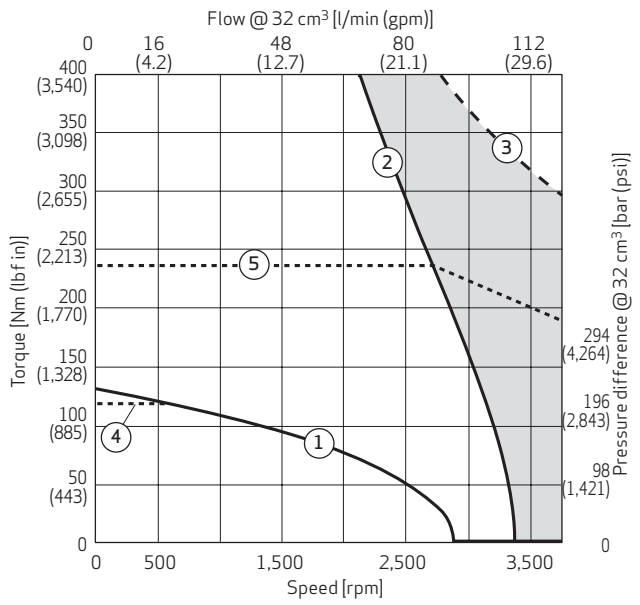
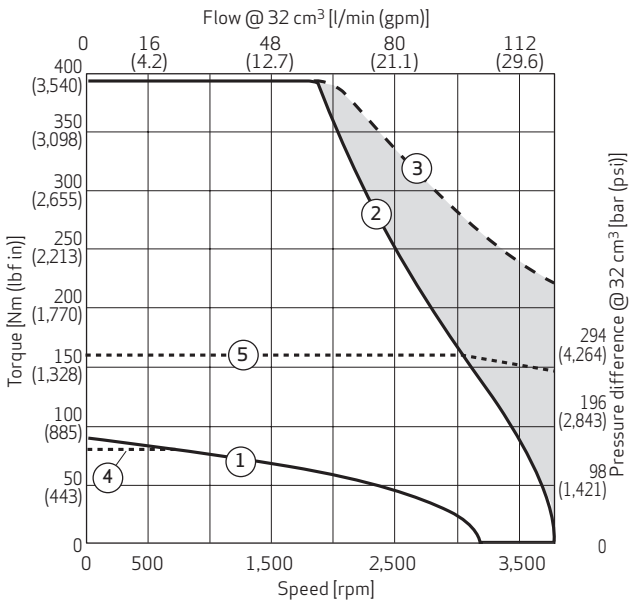

- ① Continuous torque at 110 K temperature difference over ambient, max. winding temperature 150 °C (302 °F)
- ② Maximum torque without field weakening
- ③ Maximum torque with field weakening
- ④ Continuous torque if recommended drive size is used
- ⑤ Maximum torque with field weakening if recommended drive size is used

Notes:

Motor performance with 565 V_{DC} link voltage

Motor performance does not take the pump efficiency into account

Pressure difference $\Delta p = p_A - p_B$

EPU SIZE 32

Natural Cooling, S EPU 032 A D xx xx C

Installation Drawings

S0 C

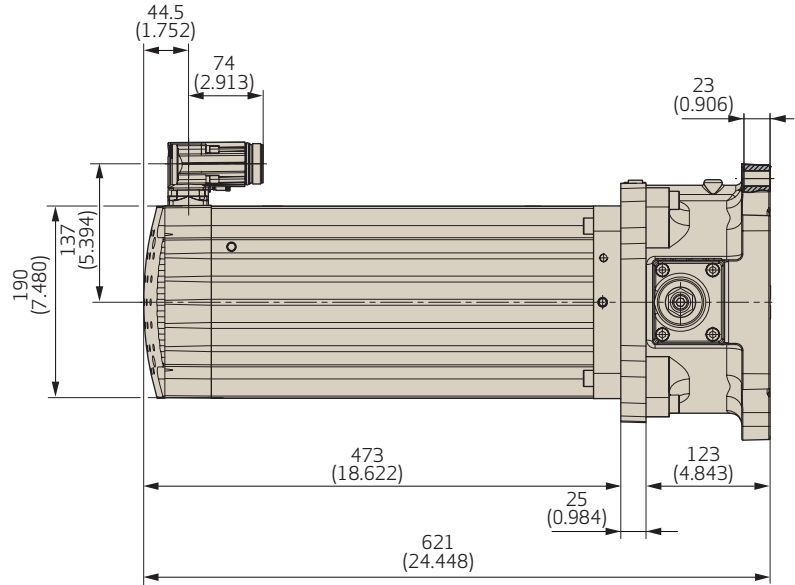

M0 C

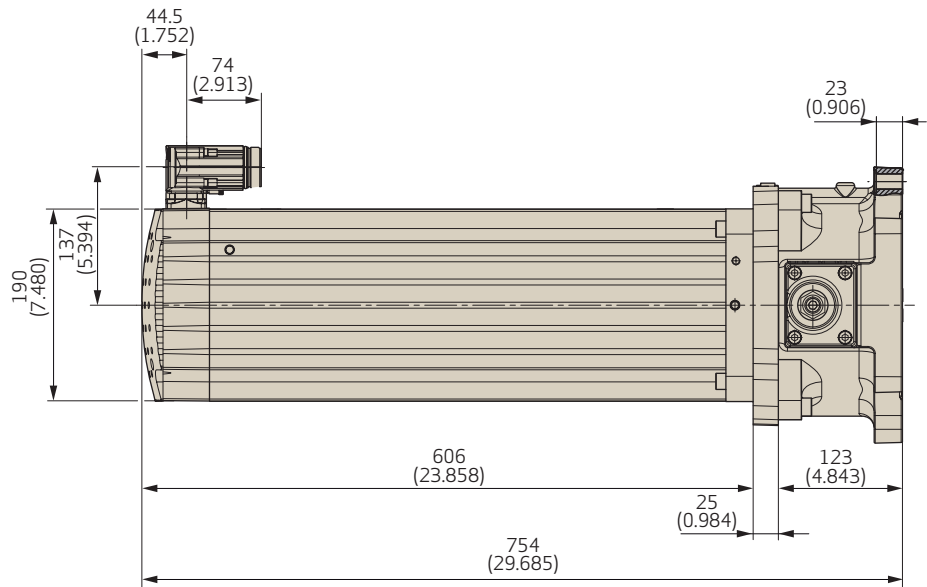

Note: Dimensions mm (inch)

EPU SIZE 32

Fan Cooling, S EPU 032 A D xx xx F

Characteristics Table

Performance class		Small	Medium	High
S EPU 032 A D xx		S0 F	M0 F	H0 F
Pump				
Displacement	V_{max}	32 cm ³ /rev (1.95 in ³ /rev)		
Maximum pump speed at 2.7 bar (abs.)	n_{max}	3,700 rpm		
Maximum pump acceleration	\dot{n}_{max}	80,400 rpm/s		
Maximum housing pressure ¹⁾	p_{Lmax}, p_{Sp}	10 bar (145 psi)		
Maximum flow	Q_{max}	118 l/min (31.2 gpm)		
Maximum pressure ports A and B	p_A, p_B	350 bar (5,076 psi)		
Flushing flow rate ⁴⁾	Q_{Sp}	3 to 4 l/min (0.8 to 1.1 gpm)		
Motor				
Continuous stall torque ³⁾	M_0	47.5 Nm (420.5 lbf in)	111.5 Nm (986.9 lbf in)	165 Nm (1,460.4 lbf in)
Rated torque ³⁾	M_n	34.2 Nm (302.8 lbf in)	76.7 Nm (678.4 lbf in)	105.6 Nm (934.6 lbf in)
Maximum torque	M_{max}	132 Nm (1,168.3 lbf in)	391 Nm (3,460.6 lbf in)	595 Nm (5,266.2 lbf in)
Rated speed	n_n	3,000 rpm	2,500 rpm	2,500 rpm
Maximum speed	n_{max}	Max. speed see M=f(n) performance curve		
Continuous stall current	I_0	27.7 A _{rms}	63.2 A _{rms}	83.2 A _{rms}
Maximum current	I_{max}	92 A _{rms}	250 A _{rms}	340 A _{rms}
Torque constant	k_t	1.7 Nm/A _{rms} (15.2 lbf in/Arms)	1.8 Nm/A _{rms} (15.6 lbf in/A)	2.0 Nm/A _{rms} (17.5 lbf in/Arms)
Voltage constant	k_e	103.3 V	106.6 V	120 V
Thermal time constant	t_{th}	3,882 s	4,200 s	5,200 s
Winding resistance at +25 °C	R_{tt}	0.35 Ohm	0.10 Ohm	0.07 Ohm
Winding inductance	L_{tt}	4.4 mH	1.7 mH	1.4 mH
Power connector		Size 1.5 rotatable		
Feedback connector		Signal resolver connector rotatable		
Fan connector		Size 1 rotatable		
Thermal sensor		NTC 220 kOhm, Pt1000		
EPU unit				
Inertia	J	81.3 kg cm ² (720 10 ⁻⁴ lbf in s ²)	164.8 kg cm ² (1,459 10 ⁻⁴ lbf in s ²)	215.7 kg cm ² (1,909 10 ⁻⁴ lbf in s ²)
Weight	m	73.7 kg (162.5 lb)	110.8 kg (244.3 lb)	134.5 kg (296.5 lb)
Tightening torque: 8x M12x45 -12.9 cylinder head screw		120 Nm + 10 Nm (1,062 lbf in + 89 lbf in)		
Servo drive				
Recommended drive size ²⁾		G392-045 size 5	G392-060 size 5	G392-072 BG5

1) See diagram "Maximum housing pressure $p_{Lmax}, p_{Sp} = f(n)$ " and "Installation note" on page 5.

2) See catalog "Modular Multi-Axis Servo Drive Systems (MSD)".

3) Operation in still air with ambient temperatures up to +40 °C (+104 °F). Winding temperature measure up to +110 °C (+230 °F) over ambient.

4) Optional via Sp port (flushing port).

EPU SIZE 32

Fan Cooling, S EPU 032 A D xx xx F

Motor Performance Curves

S0 F

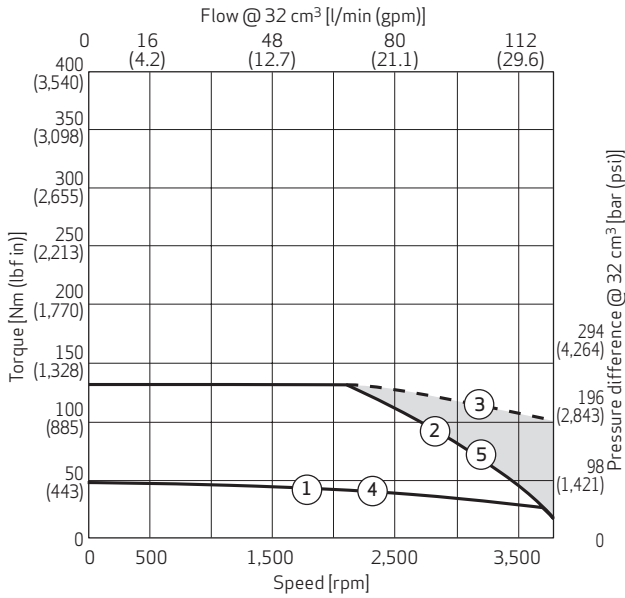

M0 F

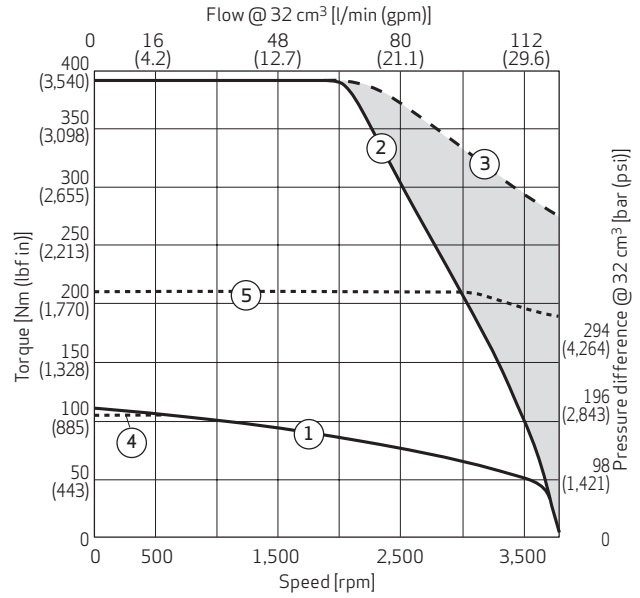

H0 F

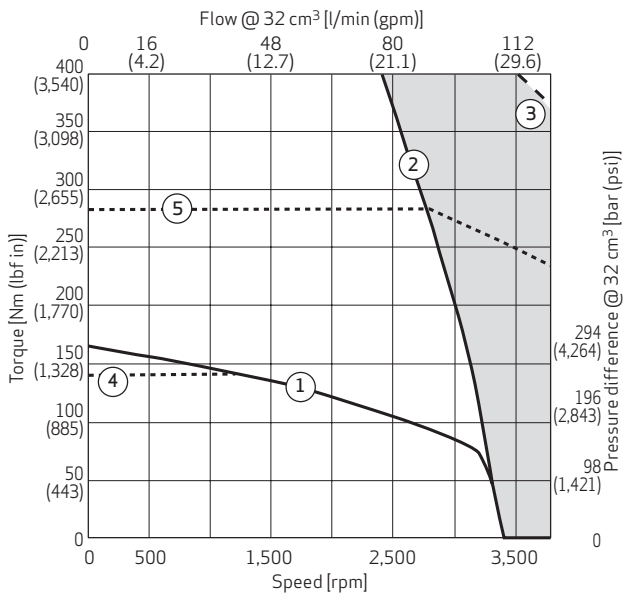

- ① Continuous torque at 110 K temperature difference over ambient, max. winding temperature 150 °C (302 °F)
- ② Maximum torque without field weakening
- ③ Maximum torque with field weakening
- ④ Continuous torque if recommended drive size is used
- ⑤ Maximum torque with field weakening if recommended drive size is used

Notes:

Motor performance with 565 V_{DC} link voltage

Motor performance does not take the pump efficiency into account

Pressure difference $\Delta p = p_A - p_B$

EPU SIZE 32

Fan Cooling, S EPU 032 A D xx xx F

Installation Drawings

S0 F

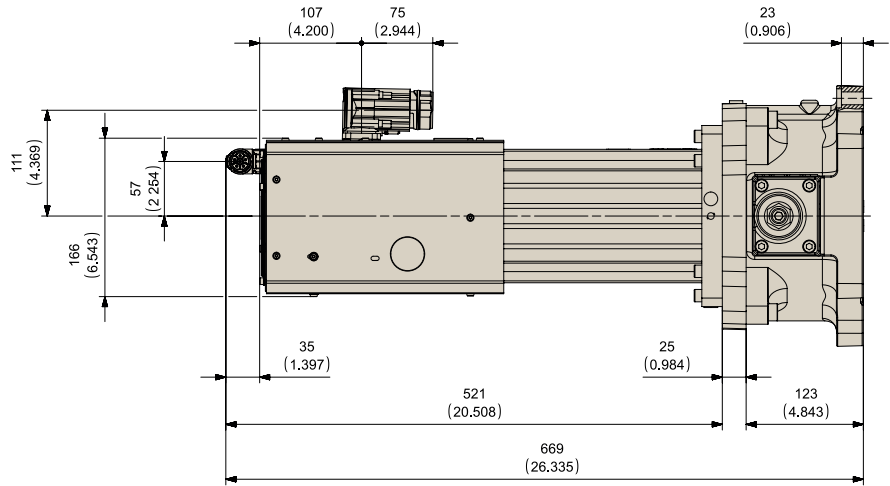

M0 F

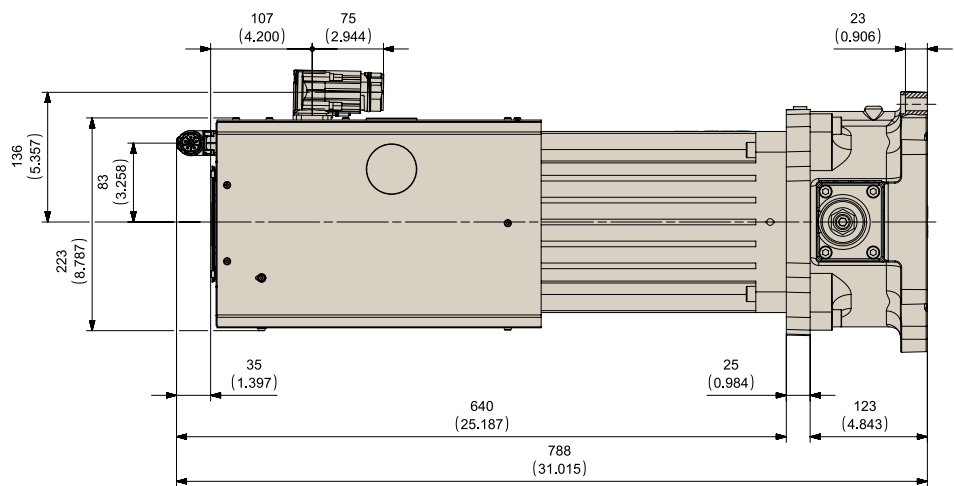

H0 F

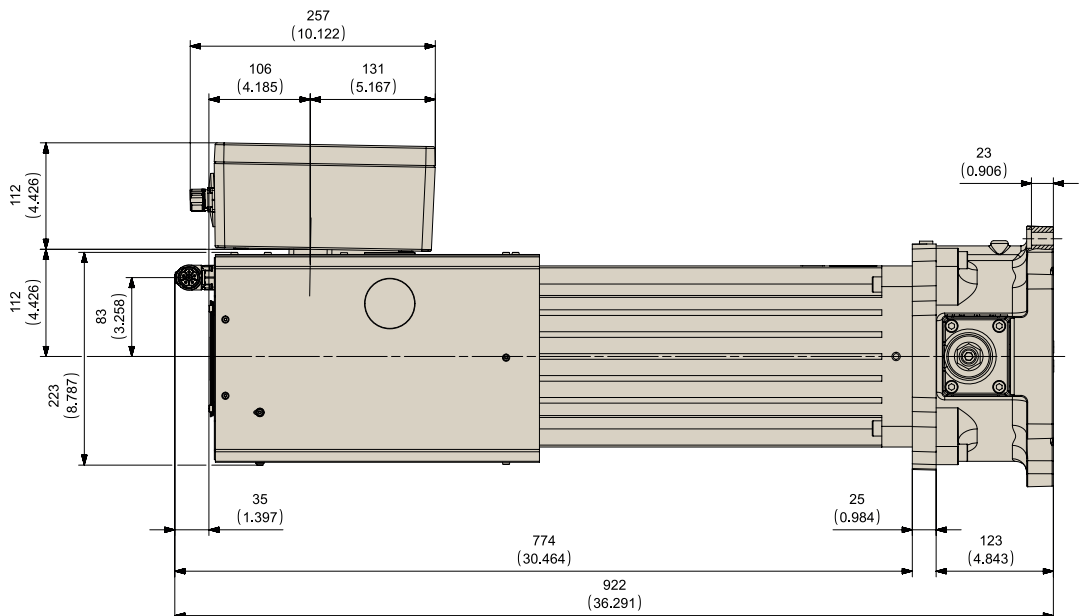

Note: Dimensions mm (inch)

EPU SIZE 32

Liquid Cooling, S EPU 032 A D xx xx W

Characteristics Table

Performance class		Small	Medium	High
S EPU 032 A D xx		S0 W	M0 W	H0 W
Pump				
Displacement	V_{max}	32 cm ³ /rev (1.95 in ³ /rev)		
Maximum pump speed at 2.7 bar (abs.)	n_{max}	3,700 rpm		
Maximum pump acceleration	\dot{n}_{max}	80,400 rpm/s		
Maximum housing pressure ¹⁾	p_{Lmax}, p_{Sp}	10 bar (145 psi)		
Maximum flow	Q_{max}	118 l/min (31.2 gpm)		
Maximum pressure ports A and B	p_A, p_B	350 bar (5,076 psi)		
Flushing flow rate ⁴⁾	Q_{Sp}	3 to 4 l/min (0.8 to 1.1 gpm)		
Motor				
Continuous stall torque ³⁾	M_0	62 Nm (549 lbf in)	91 Nm (805 lbf in)	151 Nm (1,336 lbf in)
Rated torque ³⁾	M_n	58 Nm (513 lbf in)	85 Nm (752 lbf in)	128 Nm (1,133 lbf in)
Maximum torque	M_{max}	94 Nm (832 lbf in)	140 Nm (1,239 lbf in)	391 Nm (3,461 lbf in)
Rated speed	n_n	3,000 rpm		2,500 rpm
Maximum speed	n_{max}	Maximum speed see $M = f(n)$ performance curve		
Continuous stall current	I_0	48.45 A _{rms}	54.22 A _{rms}	85.95 A _{rms}
Maximum current	I_{max}	88 A _{rms}	100 A _{rms}	250 A _{rms}
Torque constant	k_t	1.27 Nm/A _{rms}	1.68 Nm/A _{rms}	1.76 Nm/A _{rms}
Voltage constant	k_e	78.49 V _{rms} /1,000 rpm	103.67 V _{rms} /1,000 rpm	106.63 V _{rms} /1,000 rpm
Thermal time constant	t_{th}	460 s	525 s	568 s
Winding resistance at +25 °C	R_{tt}	0.319 Ω	0.345 Ω	0.096 Ω
Winding inductance	L_{tt}	3.551 mH	4.047 mH	1.727 mH
Power connector		Size 1.5 rotatable		Cable box A1
Feedback connector		Signal resolver connector rotatable		Signal resolver connector
Thermal sensor		NTC 220 kOhm, Pt1000		
Cooling water flow rate	Q_w	3 to 5 l/min (0.8 to 1.3 gpm)	3 to 5 l/min (0.8 to 1.3 gpm)	6 to 8 l/min (1.6 to 2.1 gpm)
EPU unit				
Inertia	J	75 kg cm ² (664 10 ⁻⁴ lbf in s ²)	81.2 kg cm ² (719 10 ⁻⁴ lbf in s ²)	170.5 kg cm ² (1,509 10 ⁻⁴ lbf in s ²)
Weight	m	65.1 kg (143.5 lb)	73.9 kg (162.9 lb)	107.9 kg (237.9 lb)
Tightening torque 8x M12x45 -12.9 cylinder head screw		120 Nm + 10 Nm (1,062 lbf in + 89 lbf in)		
Servo drive				
Recommended drive size ²⁾		G392-045 size 5	G392-060 size 5	G392-072 size 5

1) See diagram "Maximum housing pressure $p_{Lmax}, p_{Sp} = f(n)$ " and "Installation note" on page 5.

2) See catalog "Modular Multi-Axis Servo Drive Systems (MSD)".

3) Operation in still air with water temperatures from +25°C (+77°F) up to +40°C (+104°F). Winding temperature measure up to +110°C (+230°F) over water.

4) Optional via Sp port (flushing port).

EPU SIZE 32

Liquid Cooling, S EPU 032 A D xx xx W

Motor Performance Curves

50 W

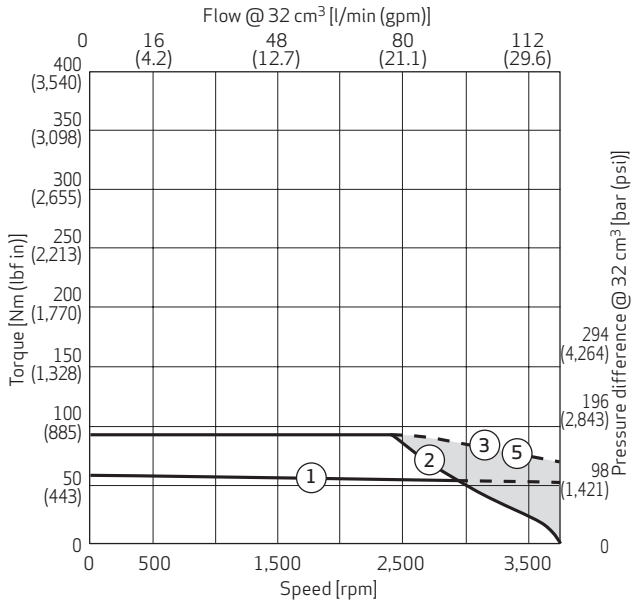

M0 W

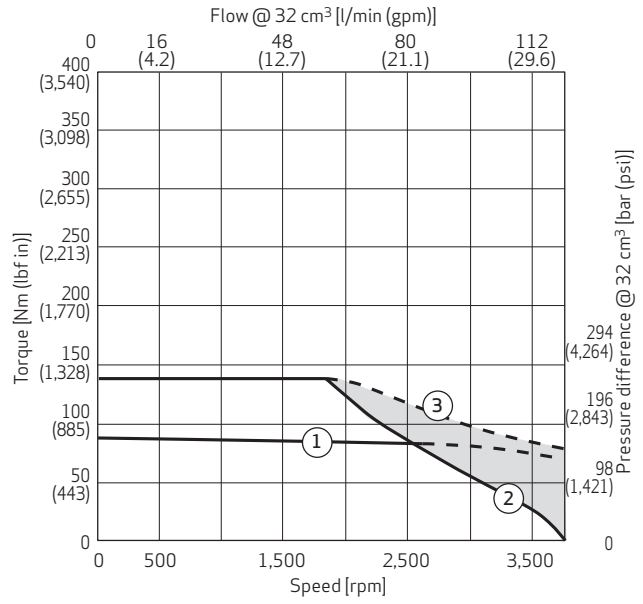

H0 W

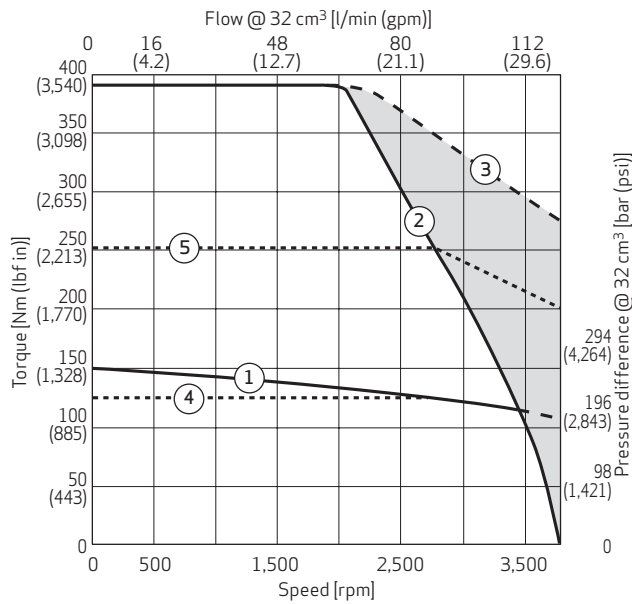

- ① Continuous torque at 110 K temperature difference over water, max. winding temperature 150 °C (302 °F)
- ② Maximum torque without field weakening
- ③ Maximum torque with field weakening
- ④ Continuous torque if recommended drive size is used
- ⑤ Maximum torque with field weakening if recommended drive size is used

Notes:

Motor performance with 565 V_{DC} link voltage

Motor performance does not take the pump efficiency into account

Pressure difference $\Delta p = p_A - p_B$

Motor performance determined with respective max. cooling water flow rate, see characteristic table

EPU SIZE 32

Liquid Cooling, S EPU 032 A D xx xx W

Installation Drawings

50 W

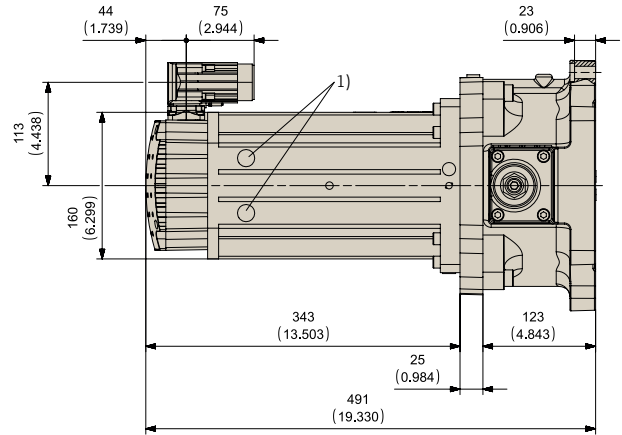

M0 W

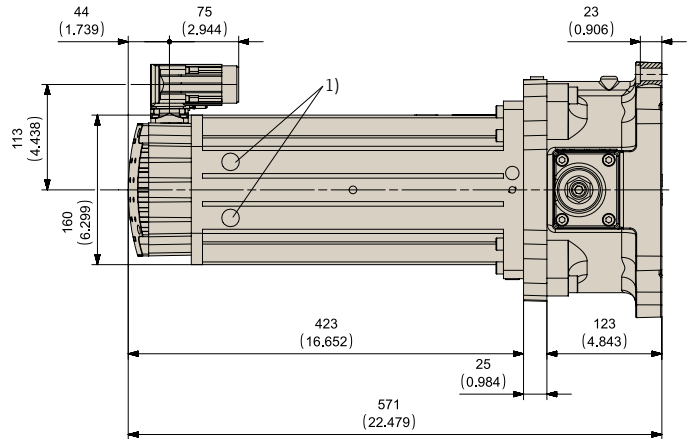

H0 W

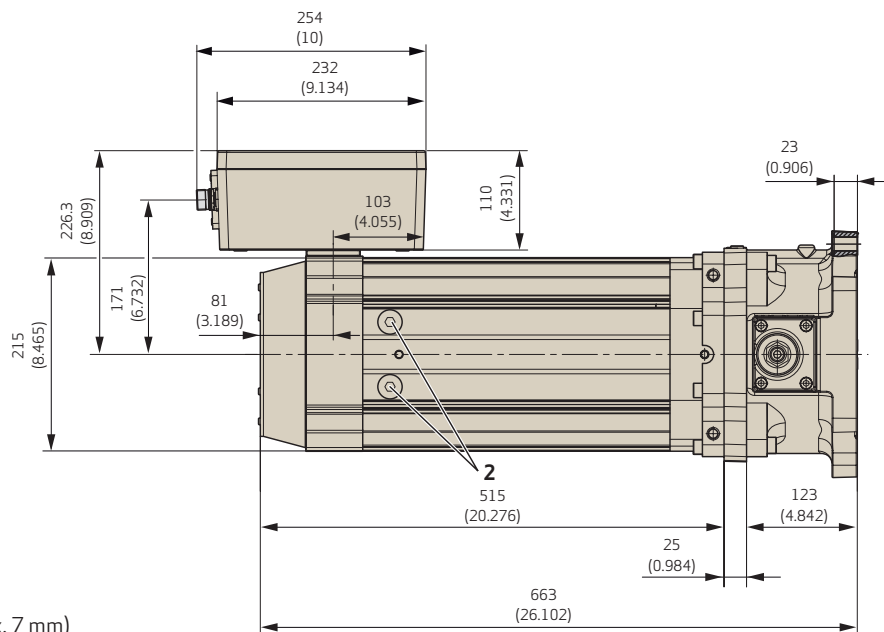

- 1) Cooler outlet G3/8" (thread depth max. 7 mm)
- 2) Cooler outlet G1/2" (thread depth max. 7 mm)

Note: Dimensions mm (inch)

EPU SIZE 80

Natural Cooling, S EPU 080 A D xx xx C

Characteristics Table

Performance class		Small	Medium	High
S EPU 080 A D xx		S0 C	M0 C	H0 C
Pump				
Displacement	V_{max}	80 cm ³ /rev (4.88 in ³ /rev)		
Maximum pump speed at 2.4 bar (abs.)	n_{max}	2,700 rpm		
Maximum pump acceleration	\dot{n}_{max}	45,000 rpm/s		
Maximum housing pressure ¹⁾	p_{Lmax}, p_{Sp}	10 bar (145 psi)		
Maximum flow	Q_{max}	216 l/min (57.1 gpm)		
Maximum pressure ports A and B	p_A, p_B	350 bar (5,076 psi)		
Flushing flow rate ⁴⁾	Q_{Sp}	4 to 6 l/min (1.1 to 1.6 gpm)		
Motor				
Continuous stall torque ³⁾	M_0	137 Nm (1,213 lbf in)	235 Nm (2,080 lbf in)	298 Nm (2,638 lbf in)
Rated torque ³⁾	M_n	52 Nm (460 lbf in)	169 Nm (1,496 lbf in)	230 Nm (2,036 lbf in)
Maximum torque	M_{max}	595 Nm (5,266 lbf in)	1,477 Nm (13,073 lbf in)	1,972 Nm (17,454 lbf in)
Rated speed	n_n	2,500 rpm	900 rpm	700 rpm
Maximum speed	n_{max}	Maximum speed see $M = f(n)$ performance curve		
Continuous stall current	I_0	69.17 A _{rms}	106.32 A _{rms}	100.63 A _{rms}
Maximum current	I_{max}	340.5 A _{rms}	795 A _{rms}	795 A _{rms}
Torque constant	k_t	1.98 Nm/A _{rms} (17.5 lbf in A _{rms})	2.21 Nm/A _{rms} (19.6 lbf in A _{rms})	2.96 Nm/A _{rms} (26.2 lbf in A _{rms})
Voltage constant	k_e	119.96 V _{rms} /1,000 _{rpm}	148.09 V _{rms} /1,000 _{rpm}	197.70 V _{rms} /1,000 _{rpm}
Thermal time constant	t_{th}	5,200 s	5,900 s	6,850 s
Winding resistance at +25 °C	R_{tt}	0.074 Ω	0.024 Ω	0.03 Ω
Winding inductance	L_{tt}	1.433 mH	0.583 mH	0.778 mH
Power connector		Size 1.5 rotatable	Cable box A2	
Feedback connector		Signal resolver connector rotatable	Signal resolver connector	
Thermal sensor		NTC 220 kOhm, Pt1000		
EPU unit				
Inertia	J	340.97 kg cm ² (3,018 10 ⁻⁴ lbf in s ²)	1207.69 kg cm ² (10,689 10 ⁻⁴ lbf in s ²)	1528.3 kg cm ² (13,527 10 ⁻⁴ lbf in s ²)
Weight	m	159.4 kg (351.4 lb)	198.6 kg (437.8 lb)	249.5 kg (550.1 lb)
Tightening torque 8x M12x45 -12.9 cylinder head screw		120 Nm + 10 Nm (1,062 lbf in + 89 lbf in)		
Servo drive				
Recommended drive size ²⁾		G392-072 size 5	G392-090 size 6	

1) See diagram "Maximum housing pressure $p_{Lmax}, p_{Sp} = f(n)$ " and "Installation note" on page 5.

2) See catalog "Modular Multi-Axis Servo Drive Systems (MSD)".

3) Operation in still air with ambient temperatures up to +40 °C (+104 °F). Winding temperature measure up to +110 °C (+230 °F) over ambient.

4) Optional via Sp port (flushing port).

EPU SIZE 80

Natural Cooling, S EPU 080 A D xx xx C

Motor Performance Curves

50 C

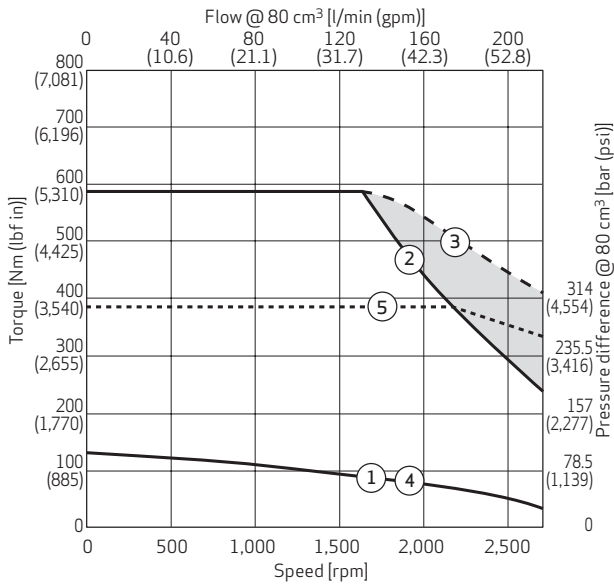

M0 C

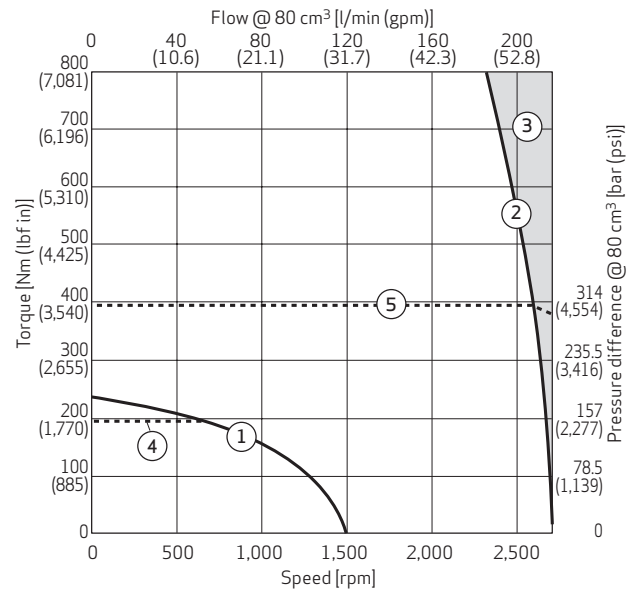

H0 C

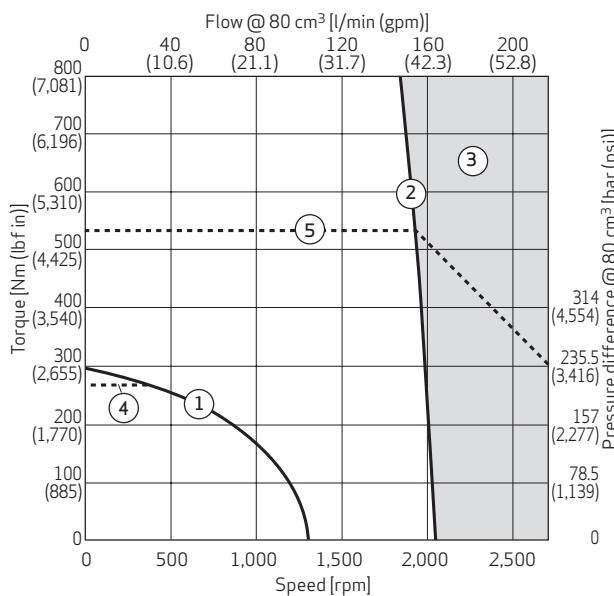

- ① Continuous torque at 110 K temperature difference over ambient, max. winding temperature 150 °C (302 °F)
- ② Maximum torque without field weakening
- ③ Maximum torque with field weakening
- ④ Continuous torque if recommended drive size is used
- ⑤ Maximum torque with field weakening if recommended drive size is used

Notes:

Motor performance with 565 V_{DC} link voltage

Motor performance does not take the pump efficiency into account

Pressure difference $\Delta p = p_A - p_B$

EPU SIZE 80

Natural Cooling, S EPU 080 A D xx xx C

Installation Drawings

S0 C

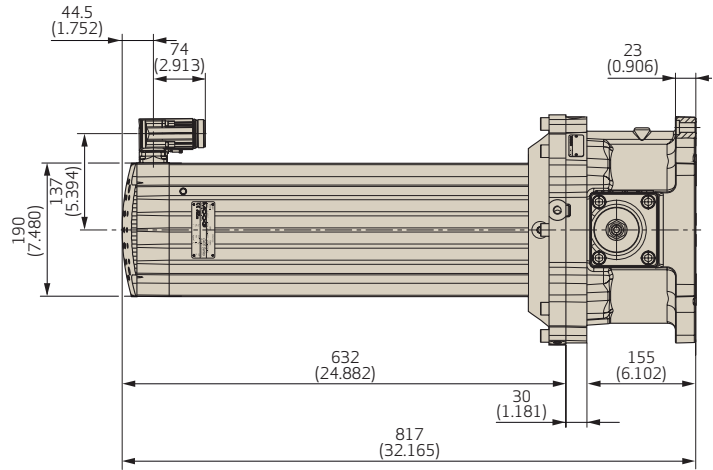

M0 C

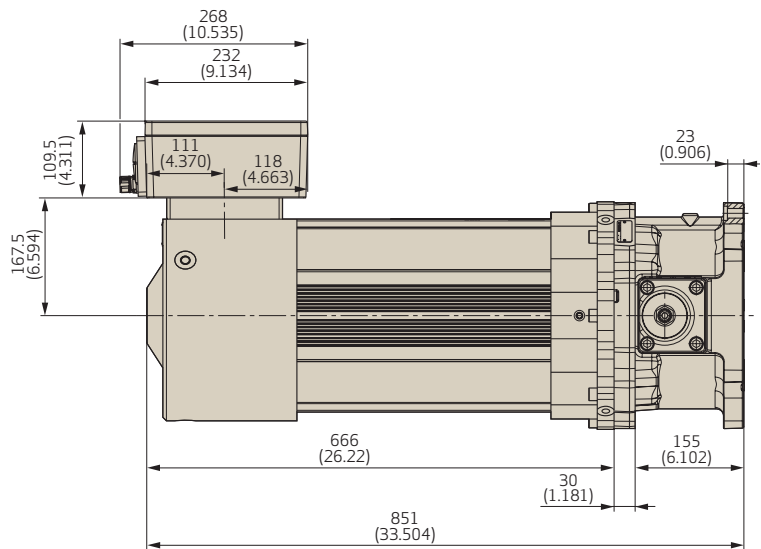

H0 C

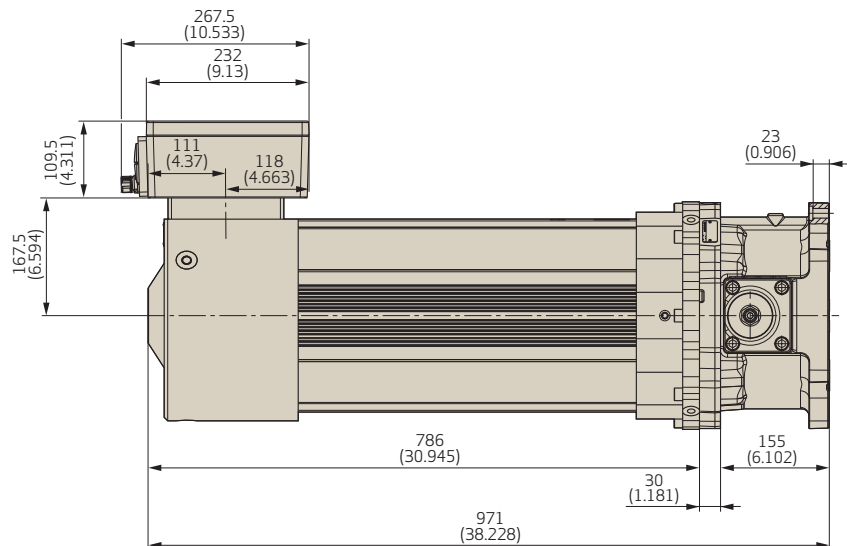

Note: Dimensions mm (inch)

EPU SIZE 80

Fan Cooling, S EPU 080 A D xx xx F

Characteristics Table

Performance class		Small	Medium	High
S EPU 080 A D xx		S0 F	M0 F	H0 F
Pump				
Displacement	V_{max}	80 cm ³ /rev (4.88 in ³ /rev)		
Maximum pump speed at 2.4 bar (abs.)	n_{max}	2,700 rpm		
Maximum pump acceleration	\dot{n}_{max}	45,000 rpm/s		
Maximum housing pressure ¹⁾	p_{Lmax}, p_{Sp}	10 bar (145 psi)		
Maximum flow	Q_{max}	216 l/min (57.1 gpm)		
Maximum pressure ports A and B	p_A, p_B	350 bar (5,076 psi)		
Flushing flow rate ⁴⁾	Q_{Sp}	4 to 6 l/min (1.1 to 1.6 gpm)		
Motor				
Continuous stall torque ³⁾	M_0	111.5 Nm (987 lbf in)	165 Nm (1,460 lbf in)	359.1 Nm (3,178 lbf in)
Rated torque ³⁾	M_n	76.7 Nm (678 lbf in)	105.6 Nm (935 lbf in)	304.5 Nm (2,695 lbf in)
Maximum torque	M_{max}	391 Nm (3,461 lbf in)	595 Nm (5,266 lbf in)	1,972 Nm (17,454 lbf in)
Rated speed	n_n	2,500 rpm		700 rpm
Maximum speed	n_{max}	Maximum speed see M = f(n) performance curve		
Continuous stall current	I_0	63.21 A _{rms}	83.2 A _{rms}	121.42 A _{rms}
Maximum current	I_{max}	250 A _{rms}	340 A _{rms}	795 A _{rms}
Torque constant	k_t	1.76 Nm/A _{rms} (15.6 lbf in A _{rms})	1.98 Nm/A _{rms} (17.5 lbf in A _{rms})	2.96 Nm/A _{rms} (26.2 lbf in A _{rms})
Voltage constant	k_e	106.63 V _{rms} /1,000 _{rpm}	119.96 V _{rms} /1,000 _{rpm}	197.48 V _{rms} /1,000 _{rpm}
Thermal time constant	t_{th}	4,200 s	5,200 s	6,850 s
Winding resistance at +25 °C	R_{tt}	0.096 Ω	0.074 Ω	0.03 Ω
Winding inductance	L_{tt}	1.721 mH	1.434 mH	0.778 mH
Power connector		Size 1.5 rotatable	Cable box A1	Cable box A2
Feedback connector		Signal resolver connector rotatable	Signal resolver connector	
Thermal sensor		NTC 220 kOhm, Pt1000		
EPU unit				
Inertia	J	290.1 kg cm ² (2,568 10 ⁻⁴ lbf in s ²)	340.9 kg cm ² (3,018 10 ⁻⁴ lbf in s ²)	1,528.3 kg cm ² (13,527 10 ⁻⁴ lbf in s ²)
Weight	m	147.2 kg (324.5 lb)	170.9 kg (437.8 lb)	256.5 kg (565.5 lb)
Tightening torque 8x M12x45 -12.9 cylinder head screw		120 Nm + 10 Nm (1,062 lbf in + 89 lbf in)		
Servo drive				
Recommended drive size ²⁾		G392-110 size 6		

1) See diagram "Maximum housing pressure $p_{Lmax}, p_{Sp} = f(n)$ " and "Installation note" on page 5.

2) See catalog "Modular Multi-Axis Servo Drive Systems (MSD)".

3) Operation in still air with ambient temperatures up to +40 °C (+104 °F). Winding temperature measure up to +110 °C (+230 °F) over ambient.

4) Optional via Sp port (flushing port).

EPU SIZE 80

Fan Cooling, S EPU 080 A D xx xx F

Motor Performance Curves

S0 F

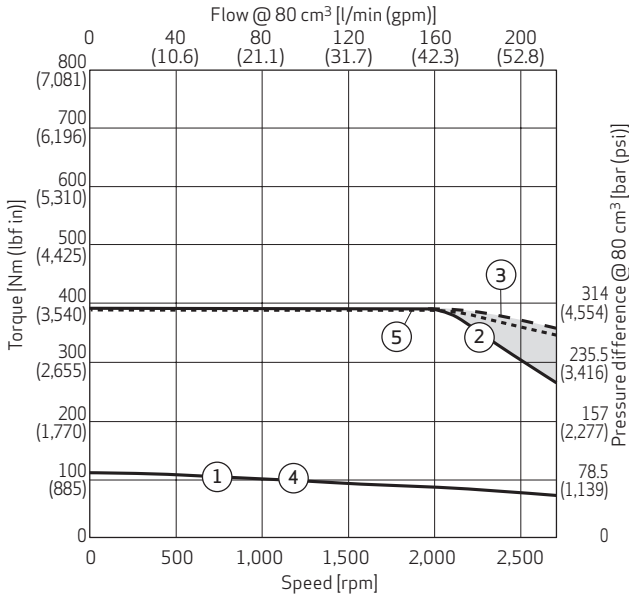

M0 F

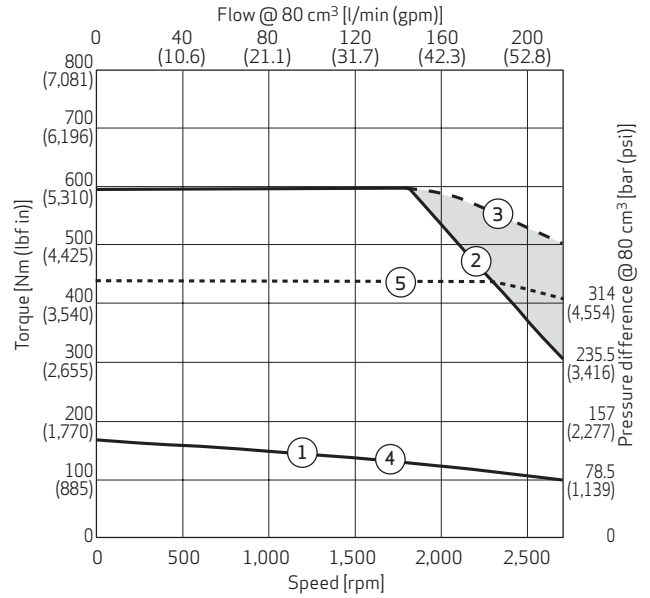

H0 F

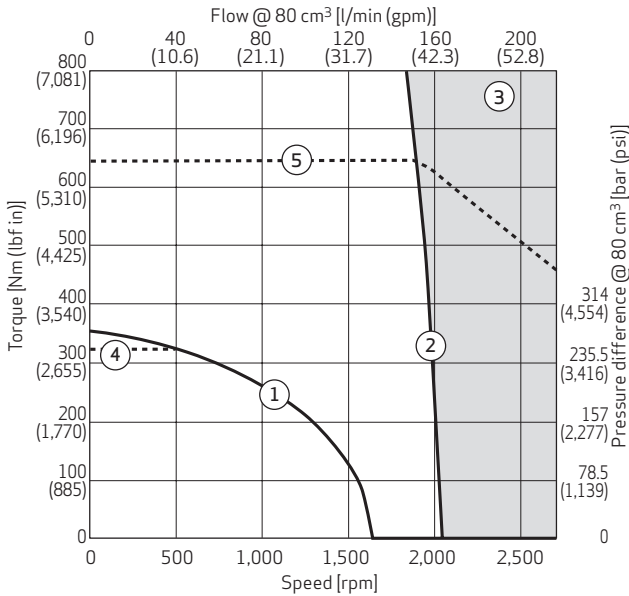

- ① Continuous torque at 110 K temperature difference over ambient, max. winding temperature 150 °C (302 °F)
- ② Maximum torque without field weakening
- ③ Maximum torque with field weakening
- ④ Continuous torque if recommended drive size is used
- ⑤ Maximum torque with field weakening if recommended drive size is used

Notes:

Motor performance with 565 V_{DC} link voltage

Motor performance does not take the pump efficiency into account

Pressure difference $\Delta p = p_A - p_B$

EPU SIZE 80

Fan Cooling, S EPU 080 A D xx xx F

Installation Drawings

S0 F

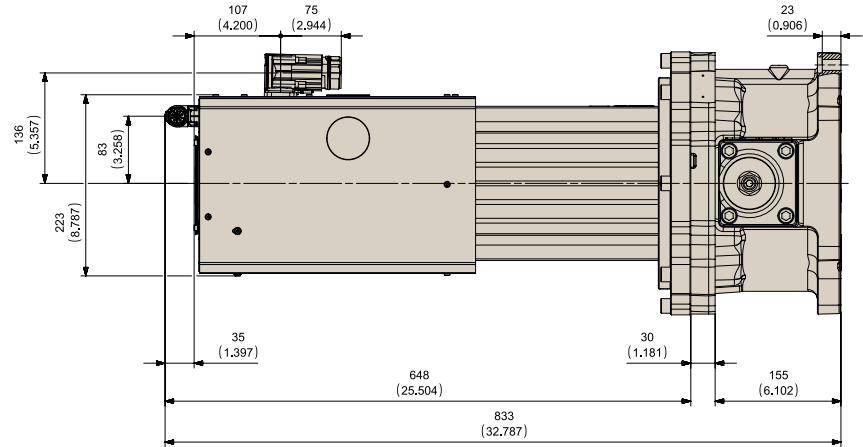

M0 F

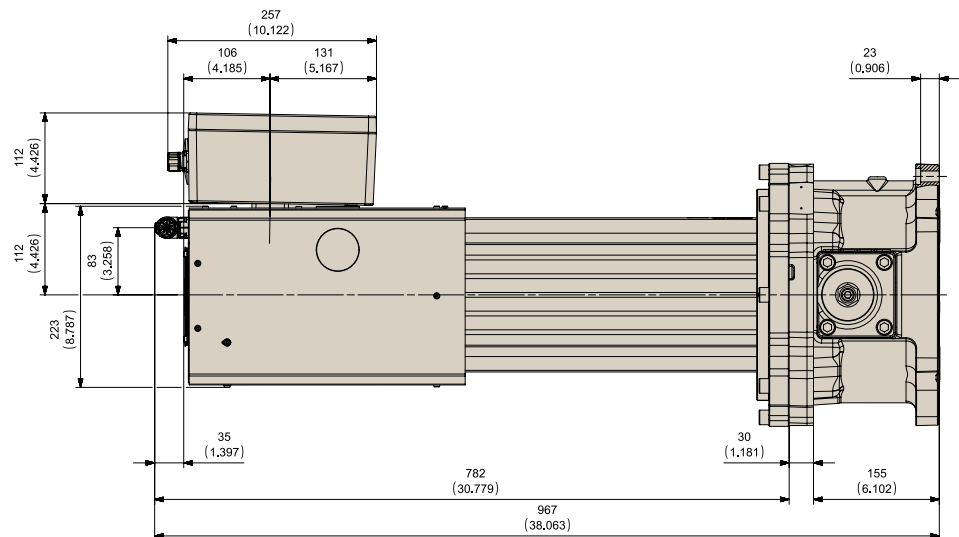

H0 F

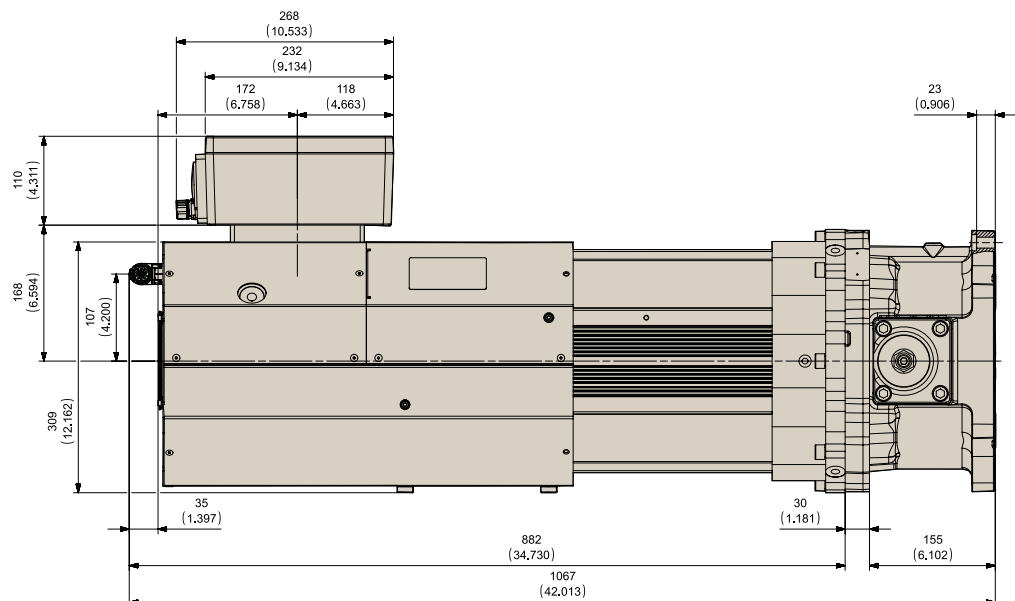

Note: Dimensions mm (inch)

EPU SIZE 80

Liquid Cooling, S EPU 080 A D xx xx W

Characteristics Table

Performance class		Small	Medium	High
S EPU 080 A D xx		SO W	MO W	HO W
Pump				
Displacement	V_{max}	80 cm ³ /rev (4.88 in ³ /rev)		
Maximum pump speed at 2.4 bar (abs.)	n_{max}	2,700 rpm		
Maximum pump acceleration	\dot{n}_{max}	45,000 rpm/s		
Maximum housing pressure ¹⁾	$p_{Lmax} \cdot p_{Sp}$	10 bar (145 psi)		
Maximum flow	Q_{max}	216 l/min (57.1 gpm)		
Maximum pressure ports A and B	p_A, p_B	350 bar (5,076 psi)		
Flushing flow rate ⁴⁾	Q_{Sp}	4 to 6 l/min (1.1 to 1.6 gpm)		
Motor				
Continuous stall torque ³⁾	M_0	151 Nm (1,336 lbf in)	227 Nm (2,009 lbf in)	498 Nm (4,408 lbf in)
Rated torque ³⁾	M_n	128 Nm (1,133 lbf in)	189 Nm (1,673 lbf in)	347 Nm (3,071 lbf in)
Maximum torque	M_{max}	391 Nm (3,461 lbf in)	595 Nm (5,266 lbf in)	1,387 Nm (12,276 lbf in)
Rated speed	n_n	2,500 rpm		1,800 rpm
Maximum speed	n_{max}	Maximum speed see $M = f(n)$ performance curve		
Continuous stall current	I_0	85.95 A _{rms}	114.87 A _{rms}	235.21 A _{rms}
Maximum current	I_{max}	250 A _{rms}	340 A _{rms}	750 A _{rms}
Torque constant	k_t	1.76 Nm/A _{rms} (15.6 lbf in/A _{rms})	1.97 Nm/A _{rms} (17.4 lbf in/A _{rms})	2.12 Nm/A _{rms} (18.8 lbf in/A _{rms})
Voltage constant	k_e	106.63 V _{rms} /1,000 _{rpm}	119.96 V _{rms} /1,000 _{rpm}	145.87 V _{rms} /1,000 _{rpm}
Thermal time constant	t_{th}	568 s	704 s	1,680 s
Winding resistance at +25 °C	R_{tt}	0.096 Ω	0.074 Ω	0.024 Ω
Winding inductance	L_{tt}	1.727 mH	1.44 mH	0.608 mH
Power connector		Cable box A1		Cable box A2
Feedback connector		Signal resolver connector		
Thermal sensor		NTC 220 kOhm, Pt1000		
Cooling water flow rate	Q_w	6 to 8 l/min (1.6 to 2.1 gpm)	6 to 8 l/min (1.6 to 2.1 gpm)	8 l/min (2.1 gpm)
EPU unit				
Inertia	J	295.8 kg cm ² (2,618 10 ⁻⁴ lbf in s ²)	346.3 kg cm ² (3,065 10 ⁻⁴ lbf in s ²)	1,207.3 kg cm ² (10,686 10 ⁻⁴ lbf in s ²)
Weight	m	144.3 kg (318.1 lb)	168.1 kg (370.6 lb)	227.5 kg (501.6 lb)
Tightening torque 8x M12x45 -12.9 cylinder head screw		120 Nm + 10 Nm (1,062 lbf in + 89 lbf in)		
Servo drive				
Recommended drive size ²⁾		G392-110 size 6		G392-143 size 6A

1) See diagram "Maximum housing pressure $p_{Lmax} \cdot p_{Sp} = f(n)$ " and "Installation note" on page 5.

2) See catalog "Modular Multi-Axis Servo Drive Systems (MSD)".

3) Operation in still air with water temperatures from +25 °C (+77 °F) up to +40 °C (+104 °F). Winding temperature measure up to +110 °C (+230 °F) over water.

4) Optional via Sp port (flushing port).

EPU SIZE 80

Liquid Cooling, S EPU 080 A D xx xx W

Motor Performance Curves

50 W

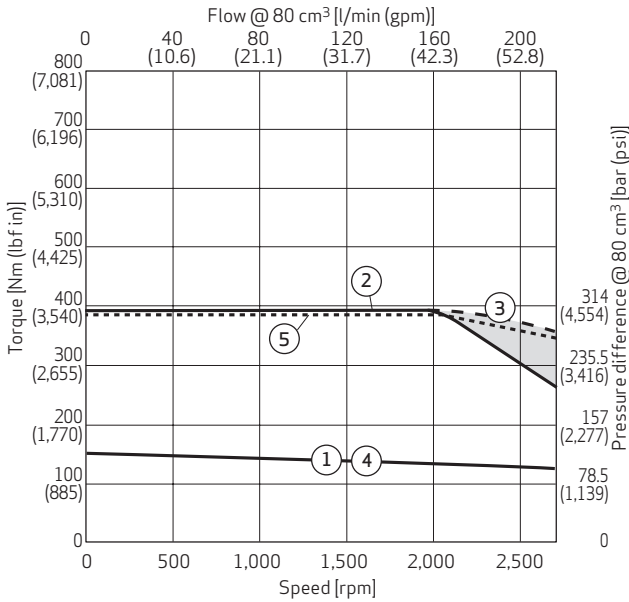

M0 W

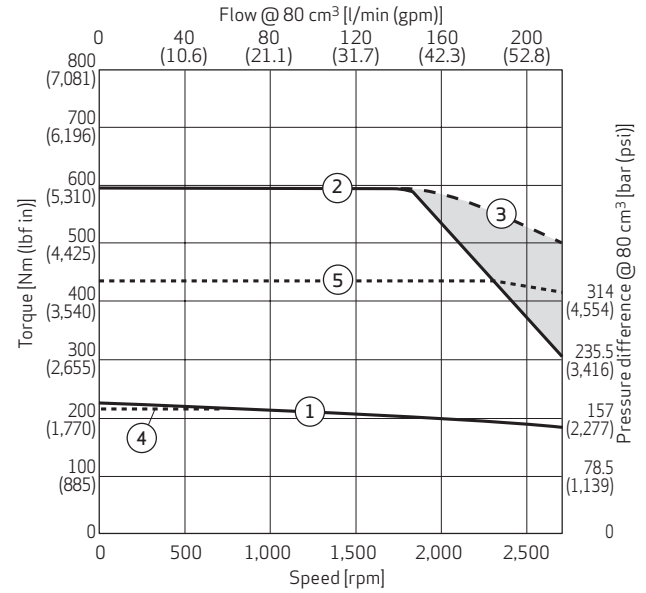

H0 W

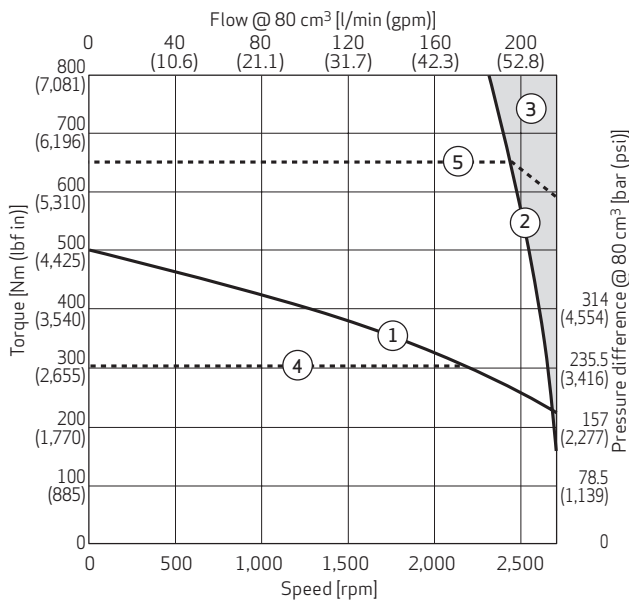

- ① Continuous torque at 110 K temperature difference over water, max. winding temperature 150 °C (302 °F)
- ② Maximum torque without field weakening
- ③ Maximum torque with field weakening
- ④ Continuous torque if recommended drive size is used
- ⑤ Maximum torque with field weakening if recommended drive size is used

Notes:

Motor performance with 565 V_{DC} link voltage

Motor performance does not take the pump efficiency into account

Pressure difference $\Delta p = p_A - p_B$

Motor performance determined with respective max. cooling water flow rate, see characteristic table

EPU SIZE 80

Liquid Cooling, S EPU 080 A D xx xx W

Installation Drawings

50 W

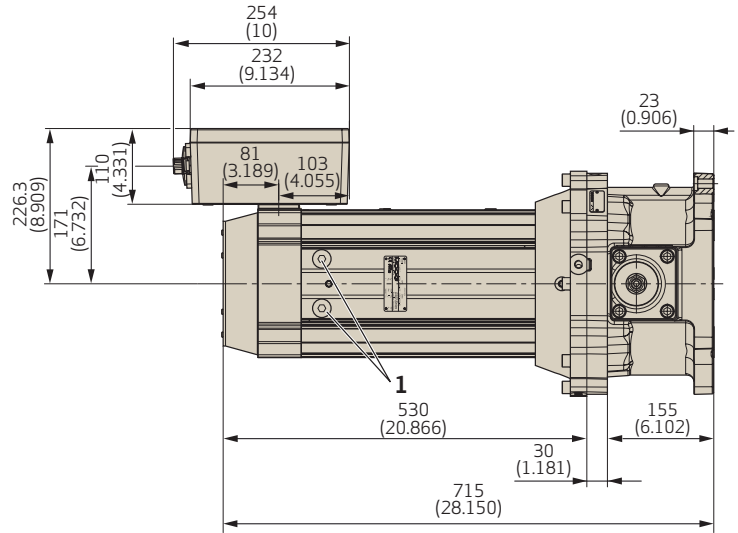

M0 W

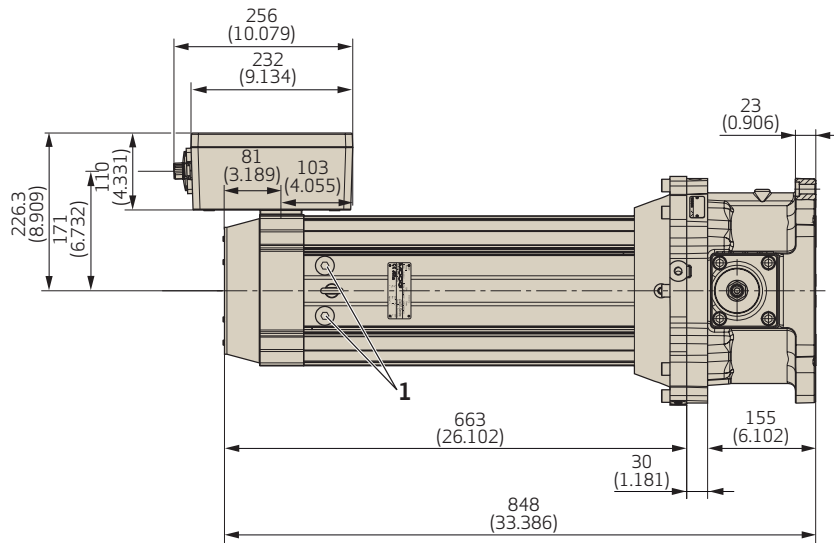

H0 W

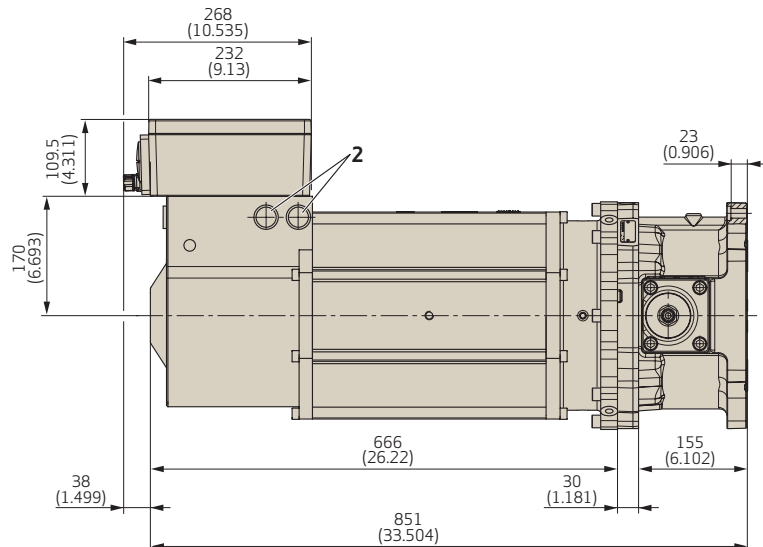

- 1) Cooler outlet G1/2" (thread depth max. 7 mm)
 - 2) Cooler outlet G3/4" (thread depth max. 16 mm)
- Note: Dimensions mm (inch)

EPU SIZE 80

Mounting Pattern and Pump Front View

Mounting Pattern

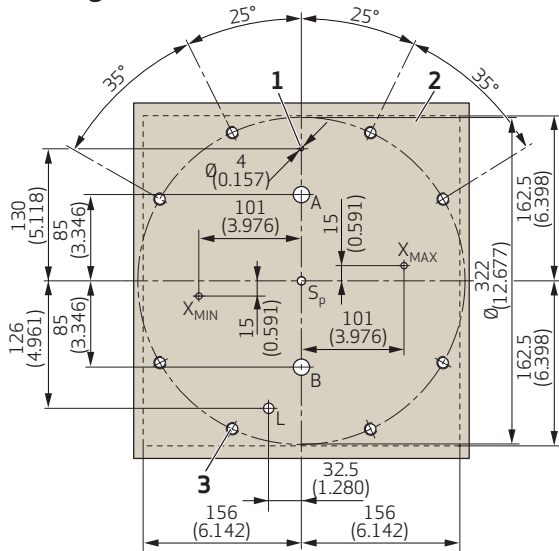

1. Use a spring-type pin with nominal diameter of 4 mm (0.16 in) (e.g. 4x12) according to ISO 13337
2. Area of
 - surface flatness: $\square 0.02$
 - surface roughness: $\sqrt{Rz4}$
3. M12, minimum 25 mm (0.9 in) deep.
Recommended: Use 8 cylinder head screws M12 (property class 12.9, minimum length 45 mm (1.8 in)) according to ISO 4762. Tightening torque 120 + 10 Nm (1,062 lbf in + 89 lbf in).

Note: Dimensions mm (inch)

Pump Front View

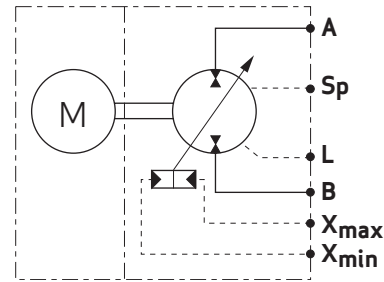
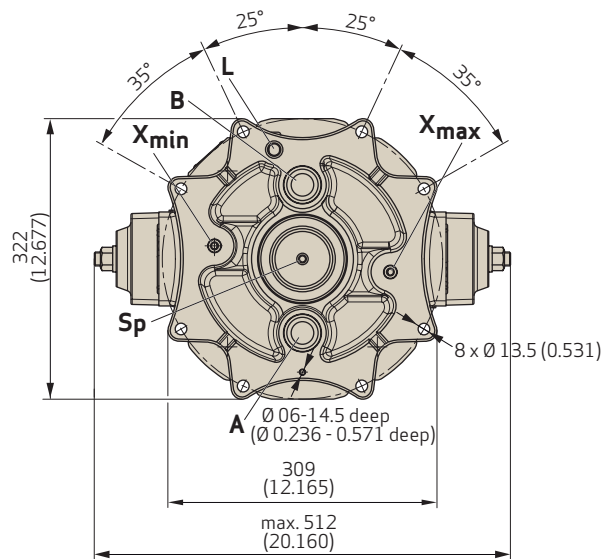

Port	Designation	Pressure [bar (psi)]	Port dimension in counter surface	
			Minimum Ø [mm (in)]	Maximum Ø [mm (in)]
A, B	Operating ports	350 (5,076)	26 (1.02)	32 (1.26)
Sp	Flushing port	10 (145)	10 (0.39)	20 (0.79)
L	Leakage port	10 (145)	16.5 (0.65)	17 (0.67)
X _{max}	Control port for maximum displacement (option N1 only)	350 (5,076)	7 (0.28)	7.5 (0.30)
X _{min}	Control port for minimum displacement (option N1 only)	350 (5,076)	7 (0.28)	7.5 (0.30)

EPU SIZE 140

Natural Cooling, S EPU 140 A D xx xx C

Characteristics Table

Performance class		Small
S EPU 140 A D xx		S0C
Pump		
Displacement	V_{max}	140 cm ³ /rev (8.54 in ³ /rev)
Maximum pump speed at 3.7 bar (abs.)	n_{max}	2,300 rpm
Maximum pump acceleration	\dot{n}_{max}	28,750 rpm/s
Maximum housing pressure ¹⁾	p_{Lmax}, p_{Sp}	10 bar (145 psi)
Maximum flow	Q_{max}	322 l/min (85.1 gpm)
Maximum pressure ports A and B	p_A, p_B	350 bar (5,076 psi)
Flushing flow rate ⁴⁾	Q_{Sp}	6 to 8 l/min (1.6 to 2.1 gpm)
Motor		
Continuous stall torque ³⁾	M_0	298 Nm (2,638 lbf in)
Rated torque ³⁾	M_n	230 Nm (2,036 lbf in)
Maximum torque	M_{max}	1,972 Nm (17,454 lbf in)
Rated speed	n_n	700 rpm
Maximum speed	n_{max}	Maximum speed see $M = f(n)$ performance curve
Continuous stall current	I_0	100.63 A _{rms}
Maximum current	I_{max}	795 A _{rms}
Torque constant	k_t	2.96 Nm/A _{rms} (26.2 lbf in/A _{rms})
Voltage constant	k_e	197.70 V _{rms} /1,000 rpm
Thermal time constant	t_{th}	6,850 s
Winding resistance at +25 °C	R_{tt}	0.03 Ω
Winding inductance	L_{tt}	0.778 mH
Power connector		Cable box A2
Feedback connector		Signal resolver connector
Thermal sensor		NTC 220 kOhm, Pt1000
EPU unit		
Inertia	J	1,722 kg cm ² (15,241 10 ⁻⁴ lbf in s ²)
Weight	m	280.8 kg (619.1 lb)
Tightening torque 12x M12x45 -12.9 cylinder head screw		120 Nm + 10 Nm (1,062 lbf in + 89 lbf in)
Servo drive		
Recommended drive size ²⁾		G392-143 size 6

1) See diagram "Maximum housing pressure $p_{Lmax}, p_{Sp} = f(n)$ " and "Installation note" on page 5.

2) See catalog "Modular Multi-Axis Servo Drive Systems (MSD)".

3) Operation in still air with ambient temperatures up to +40 °C (+104 °F). Winding temperature measure up to +110 °C (+230 °F) over ambient.

4) Optional via Sp port (flushing port).

EPU SIZE 140

Natural Cooling, S EPU 140 A D xx xx C

Motor Performance Curves

50 C

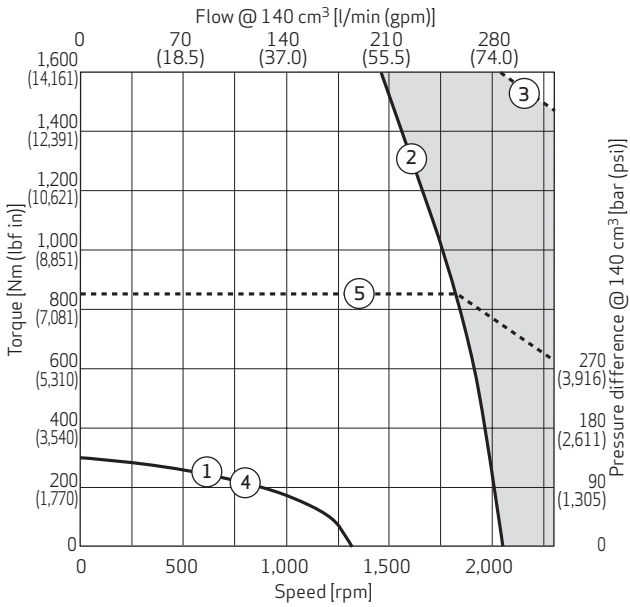

- ① Continuous torque at 110 K temperature difference over ambient, max. winding temperature 150 °C (302 °F)
- ② Maximum torque without field weakening
- ③ Maximum torque with field weakening
- ④ Continuous torque if recommended drive size is used
- ⑤ Maximum torque with field weakening if recommended drive size is used

Notes:

Motor performance with 565 V_{DC} link voltage

Motor performance does not take the pump efficiency into account

Pressure difference $\Delta p = p_A - p_B$

EPU SIZE 140

Natural Cooling, S EPU 140 A D xx xx C

Installation Drawings

S0 C

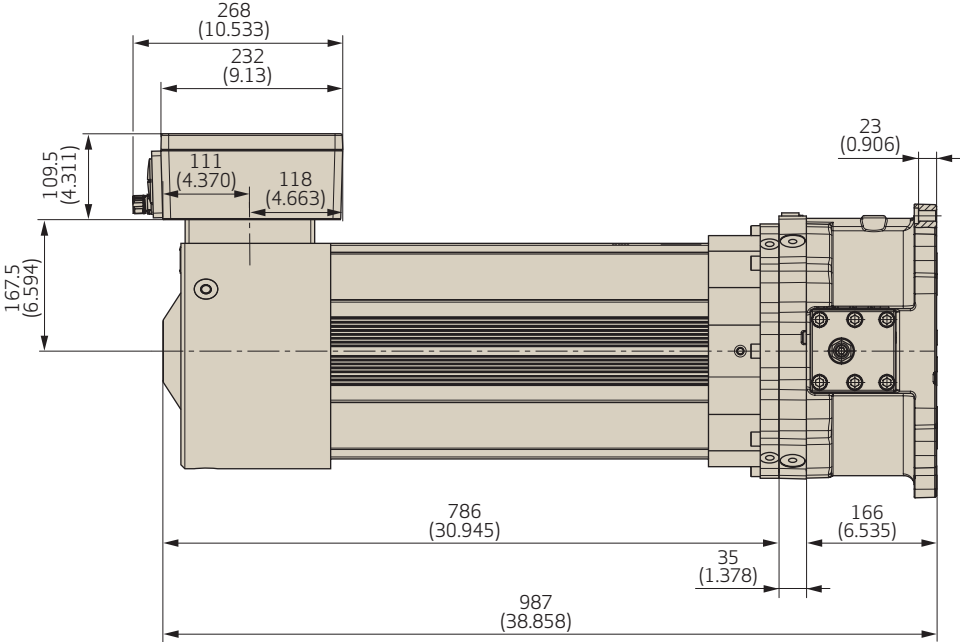

Note: Dimensions mm (inch)

EPU SIZE 140

Fan Cooling, S EPU 140 A D xx xx F

Characteristics Table

Performance class		Small	Medium
S EPU 140 A D xx		S0 F	M0 F
Pump			
Displacement	V_{max}	140 cm ³ /rev (8.54 in ³ /rev)	
Maximum pump speed at 3.7 bar (abs.)	n_{max}	2,300 rpm	
Maximum pump acceleration	\dot{n}_{max}	28,750 rpm/s	
Maximum housing pressure ¹⁾	p_{Lmax}, p_{Sp}	10 bar (145 psi)	
Maximum flow	Q_{max}	322 l/min (85.1 gpm)	
Maximum pressure ports A and B	p_A, p_B	350 bar (5,076 psi)	
Flushing flow rate ⁴⁾	Q_{Sp}	6 to 8 l/min (1.6 to 2.1 gpm)	
Motor			
Continuous stall torque ³⁾	M_0	165 Nm (1,460 lbf in)	359.1 Nm (3,178 lbf in)
Rated torque ³⁾	M_n	105.6 Nm (935 lbf in)	304.5 Nm (2,695 lbf in)
Maximum torque	M_{max}	595 Nm (5,266 lbf in)	1,972 Nm (17,453 lbf in)
Rated speed	n_n	2,500 rpm	700 rpm
Maximum speed	n_{max}	Maximum speed see $M = f(n)$ performance curve	
Continuous stall current	I_0	83.2 A _{rms}	121.42 A _{rms}
Maximum current	I_{max}	340 A _{rms}	795 A _{rms}
Torque constant	k_t	1.98 Nm/A _{rms} (17.5 lbf in/A _{rms})	2.96 Nm/A _{rms} (26.2 lbf in/A _{rms})
Voltage constant	k_e	119.96 V _{rms} /1,000 _{rpm}	197.48 V _{rms} /1,000 _{rpm}
Thermal time constant	t_{th}	5,200 s	6,850 s
Winding resistance at +25 °C	R_{tt}	0.074 Ω	0.03 Ω
Winding inductance	L_{tt}	1.434 mH	0.778 mH
Power connector		Cable box A1	Cable box A2
Feedback connector		Signal resolver connector rotatable	
Fan connector		Size 1 rotatable	
Thermal sensor		NTC 220 kOhm, Pt1000	
EPU unit			
Inertia	J	535 kg cm ² (4,732 10 ⁻⁴ lbf in s ²)	1,722 kg cm ² (15,241 10 ⁻⁴ lbf in s ²)
Weight	m	202.2 kg (445.8 lb)	287.8 kg (634.4 lb)
Tightening torque 12x M12x50 -12.9 cylinder head screw		120 Nm + 10 Nm (1,062 lbf in + 89 lbf in)	
Servo drive			
Recommended drive size ²⁾		G392-143 size 6	G392-110 size 6

1) See diagram "Maximum housing pressure $p_{Lmax}, p_{Sp} = f(n)$ " and "Installation note" on page 5.

2) See catalog "Modular Multi-Axis Servo Drive Systems (MSD)".

3) Operation in still air with ambient temperatures up to +40 °C (+104 °F). Winding temperature measure up to +110 °C (+230 °F) over ambient.

4) Optional via Sp port (flushing port).

EPU SIZE 140

Fan Cooling, S EPU 140 A D xx xx F

Motor Performance Curves

S0 F

M0 F

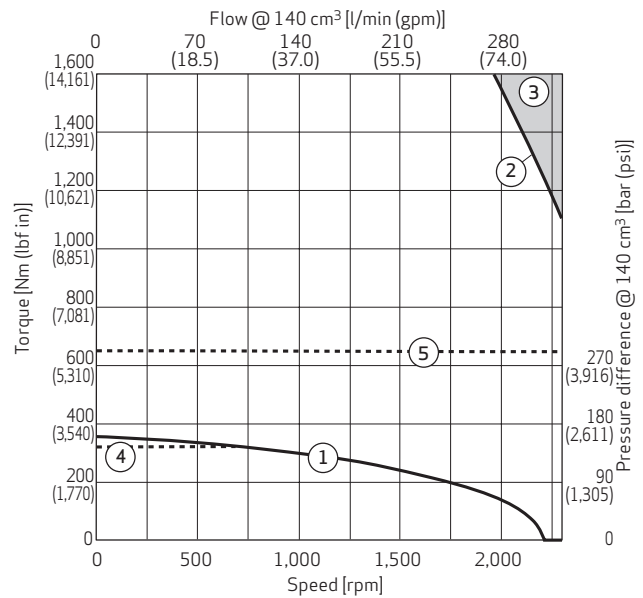
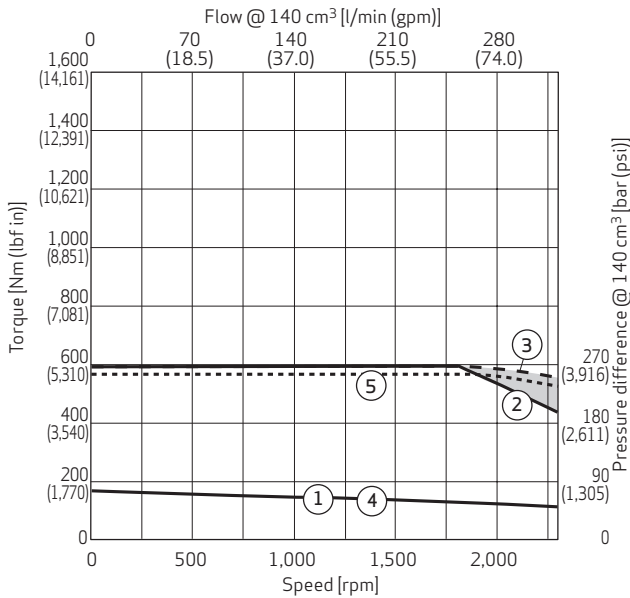

- ① Continuous torque at 110 K temperature difference over ambient, max. winding temperature 150 °C (302 °F)
- ② Maximum torque without field weakening
- ③ Maximum torque with field weakening
- ④ Continuous torque if recommended drive size is used
- ⑤ Maximum torque with field weakening if recommended drive size is used

Notes:

Motor performance with 565 V_{DC} link voltage

Motor performance does not take the pump efficiency into account

Pressure difference $\Delta p = p_A - p_B$

EPU SIZE 140

Fan Cooling, S EPU 140 A D xx xx F

Installation Drawings

S0F

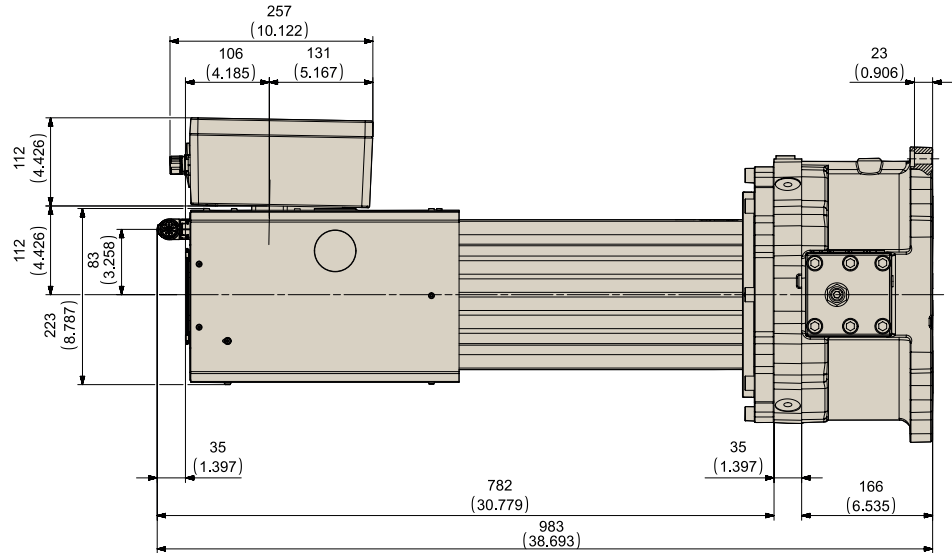

M0F

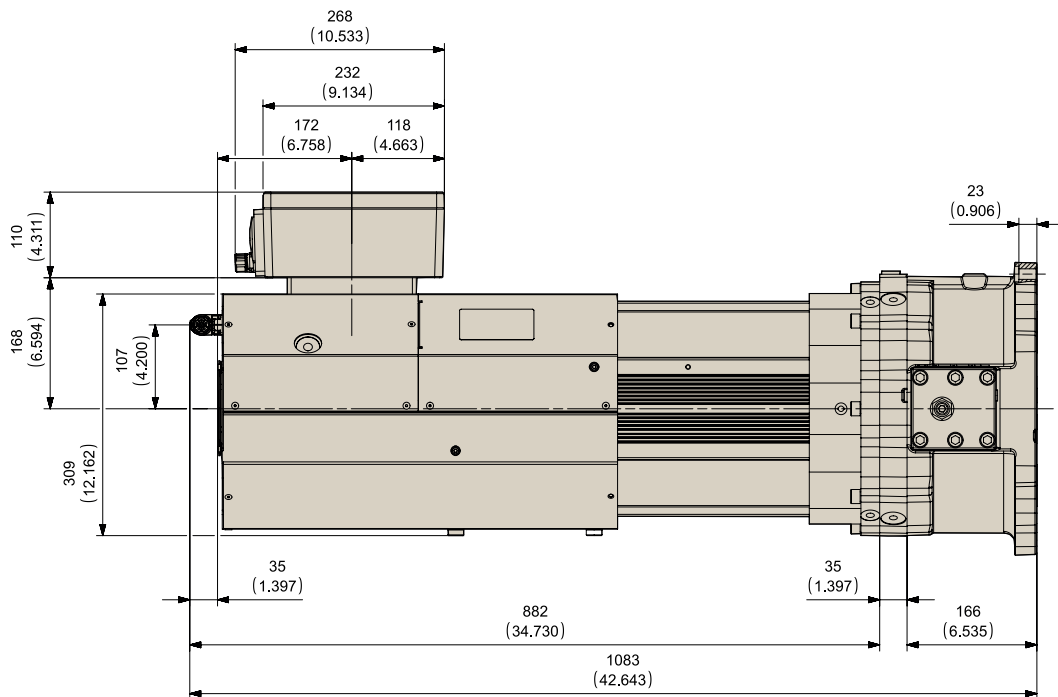

Note: Dimensions mm (inch)

EPU SIZE 140

Liquid Cooling, S EPU 140 A D xx xx W

Characteristics Table

Performance class		Small	Medium	High
S EPU 140 A D xx		SO W	MO W	HO W
Pump				
Displacement	V_{max}	140 cm ³ /rev (8.54 in ³ /rev)		
Maximum pump speed at 3.7 bar (abs.)	n_{max}	2,300 rpm		
Maximum pump acceleration	\dot{n}_{max}	28,750 rpm/s		
Maximum housing pressure ¹⁾	p_{Lmax}, p_{Sp}	10 bar (145 psi)		
Maximum flow	Q_{max}	322 l/min (85.1 gpm)		
Maximum pressure ports A and B	p_A, p_B	350 bar (5,076 psi)		
Flushing flow rate ⁴⁾	Q_{Sp}	6 to 8 l/min (1.6 to 2.1 gpm)		
Motor				
Continuous stall torque ³⁾	M_0	227 Nm (2,009 lbf in)	498 Nm (4,408 lbf in)	654 Nm (5,788 lbf in)
Rated torque ³⁾	M_n	189 Nm (1,673 lbf in)	347 Nm (3,071 lbf in)	427 Nm (3,779 lbf in)
Maximum torque	M_{max}	595 Nm (5,266 lbf in)	1,387 Nm (12,276 lbf in)	1,950 Nm (17,259 lbf in)
Rated speed	n_n	2,500 rpm	1,800 rpm	1,800 rpm
Maximum speed	n_{max}	Maximum speed see $M = f(n)$ performance curve		
Continuous stall current	I_0	114.87 A _{rms}	235.21 A _{rms}	230.9 A _{rms}
Maximum current	I_{max}	340 A _{rms}	750 A _{rms}	795 A _{rms}
Torque constant	k_t	1.97 Nm/A _{rms} (17.4 lbf in/A _{rms})	2.12 Nm/A _{rms} (18.8 lbf in/A _{rms})	2.83 Nm/A _{rms} (25.0 lbf in/A _{rms})
Voltage constant	k_e	119.96 V _{rms} /1,000 _{rpm}	145.87 V _{rms} /1,000 _{rpm}	195.48 V _{rms} /1,000 _{rpm}
Thermal time constant	t_{th}	704 s	1,680 s	1,970 s
Winding resistance at +25 °C	R_{tt}	0.074 Ω	0.024 Ω	0.03 Ω
Winding inductance	L_{tt}	1.44 mH	0.608 mH	0.804 mH
Power connector		Cable box A1	Cable box A2	
Feedback connector		Signal resolver connector		
Thermal sensor		NTC 220 kOhm, Pt1000		
Cooling water flow rate	Q_W	6 to 8 l/min (1.6 to 2.1 gpm)	8 l/min (2.1 gpm)	
EPU unit				
Inertia	J	540 kg cm ² (4,779 10 ⁻⁴ lbf in s ²)	1,401 kg cm ² (12,400 10 ⁻⁴ lbf in s ²)	1,722 kg cm ² (15,241 10 ⁻⁴ lbf in s ²)
Weight	m	199.4 kg (439.6 lb)	258.8 kg (570.6 lb)	295.8 kg (652.1 lb)
Tightening torque 12x M12x45 -12.9 cylinder head screw		120 Nm + 10 Nm (1,062 lbf in + 89 lbf in)		
Servo drive				
Recommended drive size ²⁾		G392-143 size 6A	G395-210 size 6A	

1) See diagram “Maximum housing pressure $p_{Lmax}, p_{Sp} = f(n)$ ” and “Installation note” on page 5.

2) See catalog “Modular Multi-Axis Servo Drive Systems (MSD)”.

3) Operation in still air with water temperatures from +25 °C (+77 °F) up to +40 °C (+104 °F). Winding temperature measure up to +110 °C (+230 °F) over water.

4) Optional via Sp port (flushing port).

EPU SIZE 140

Liquid Cooling, S EPU 140 A D xx xx W

Motor Performance Curves

50 W

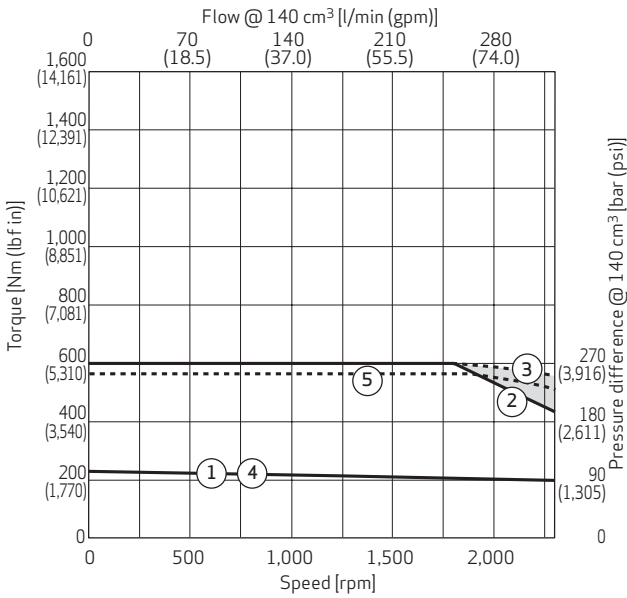

M0 W

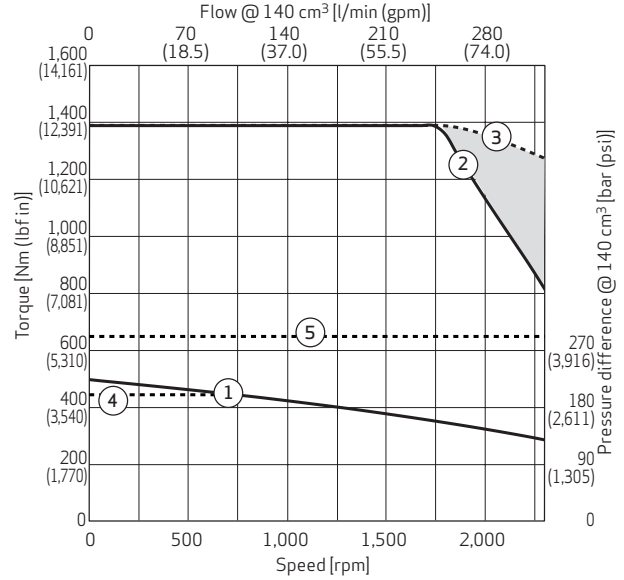

H0 W

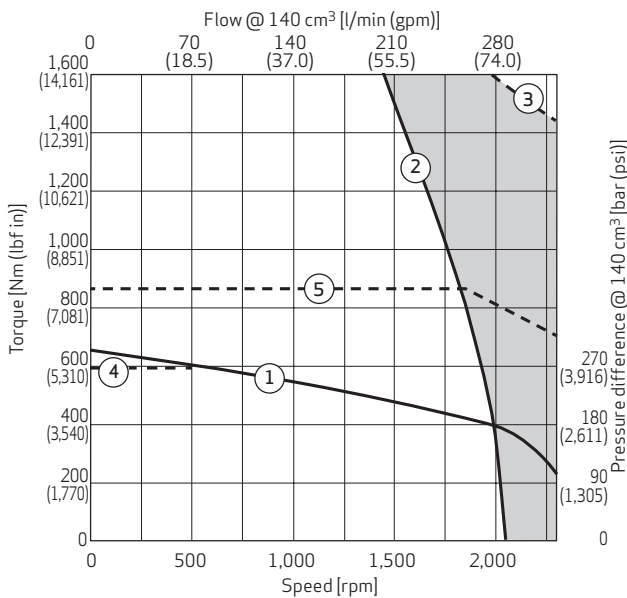

- ① Continuous torque at 110 K temperature difference over water, max. winding temperature 150 °C (302 °F)
- ② Maximum torque without field weakening
- ③ Maximum torque with field weakening
- ④ Continuous torque if recommended drive size is used
- ⑤ Maximum torque with field weakening if recommended drive size is used

Notes:

Motor performance with 565 V_{DC} link voltage

Motor performance does not take the pump efficiency into account

Pressure difference $\Delta p = p_A - p_B$

Motor performance determined with respective max. cooling water flow rate, see characteristic table

EPU SIZE 140

Liquid Cooling, S EPU 140 A D xx xx W

Installation Drawings

50 W

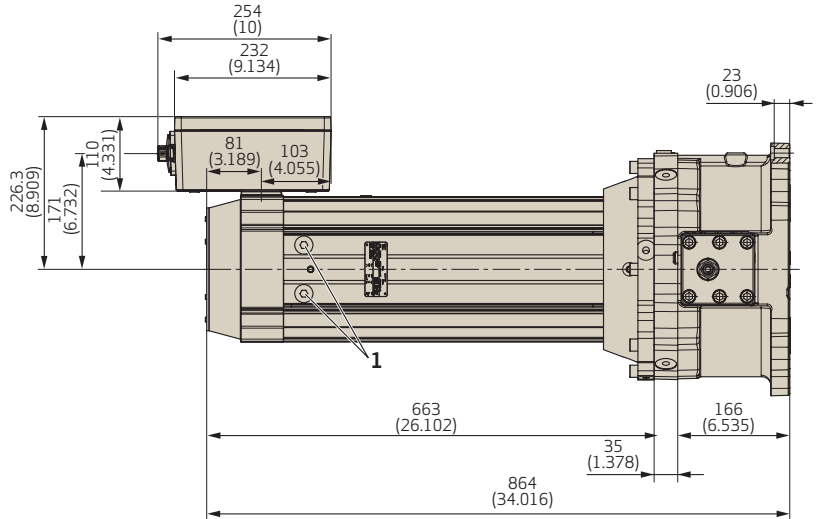

M0 W

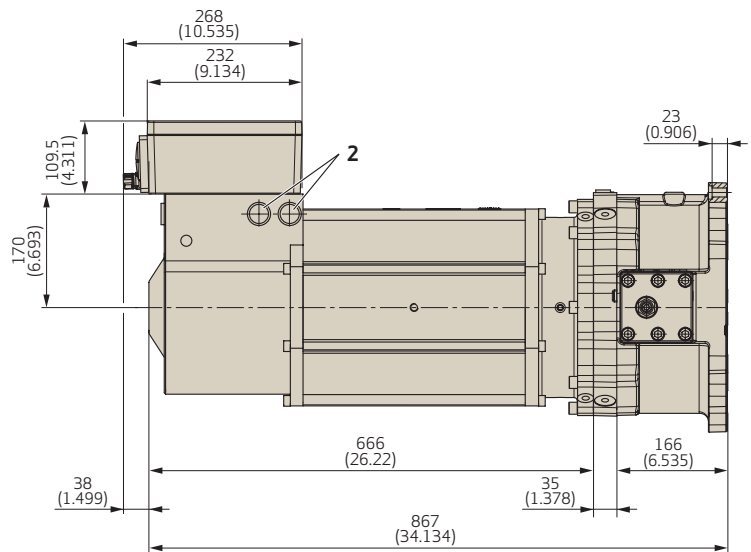

H0 W

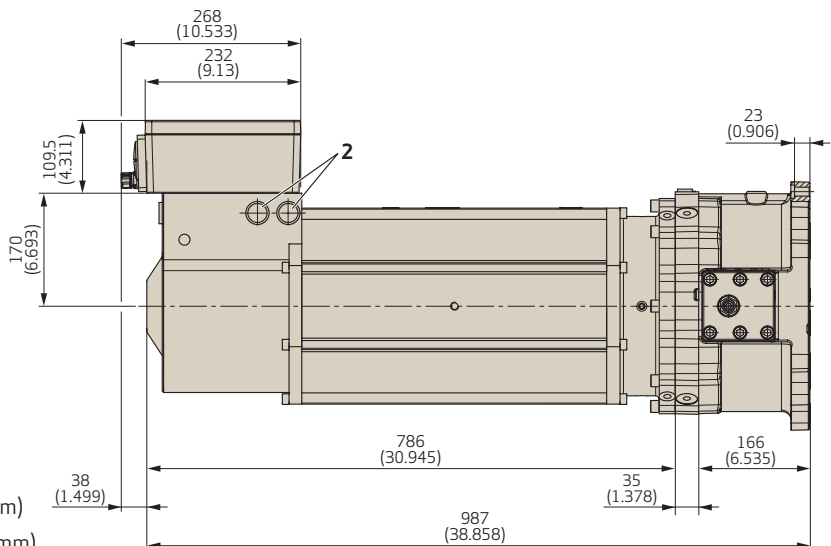

Note: Dimensions mm (inch)

1) Cooler outlet G1/2" (thread depth max. 7 mm)

2) Cooler outlet G3/4" (thread depth max. 16 mm)

ELECTRICAL INTERFACES

Power Connectors

Size 1

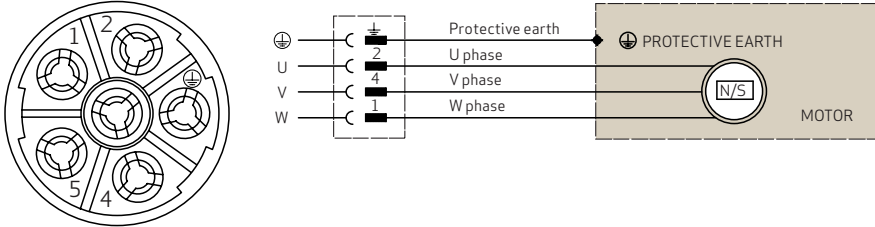

Size 1.5

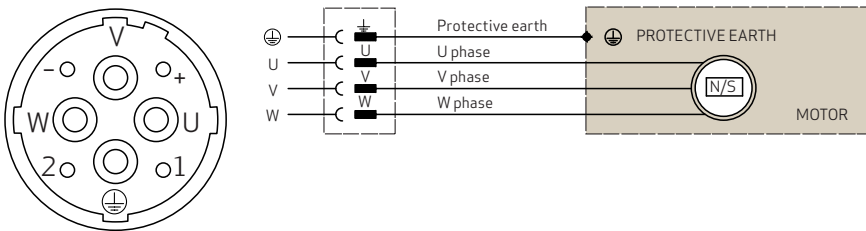

Cable Box A1

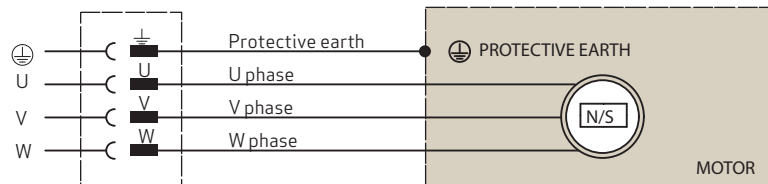
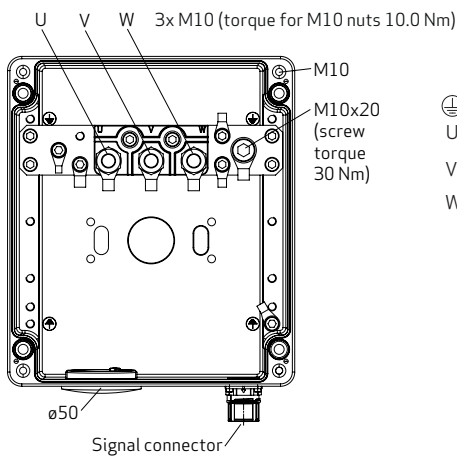

Cable Box A2

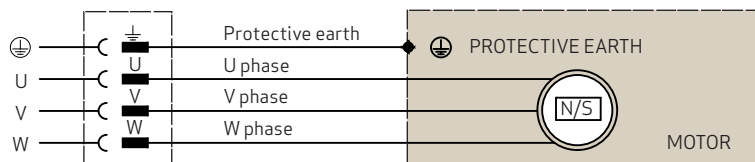
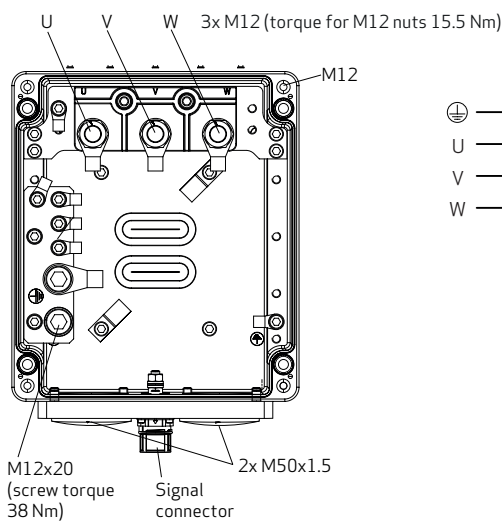

For more information on connectors, please see Moog Maximum Dynamic Brushless Servo Motor User Manual.

ELECTRICAL INTERFACES

Signal Resolver Connector

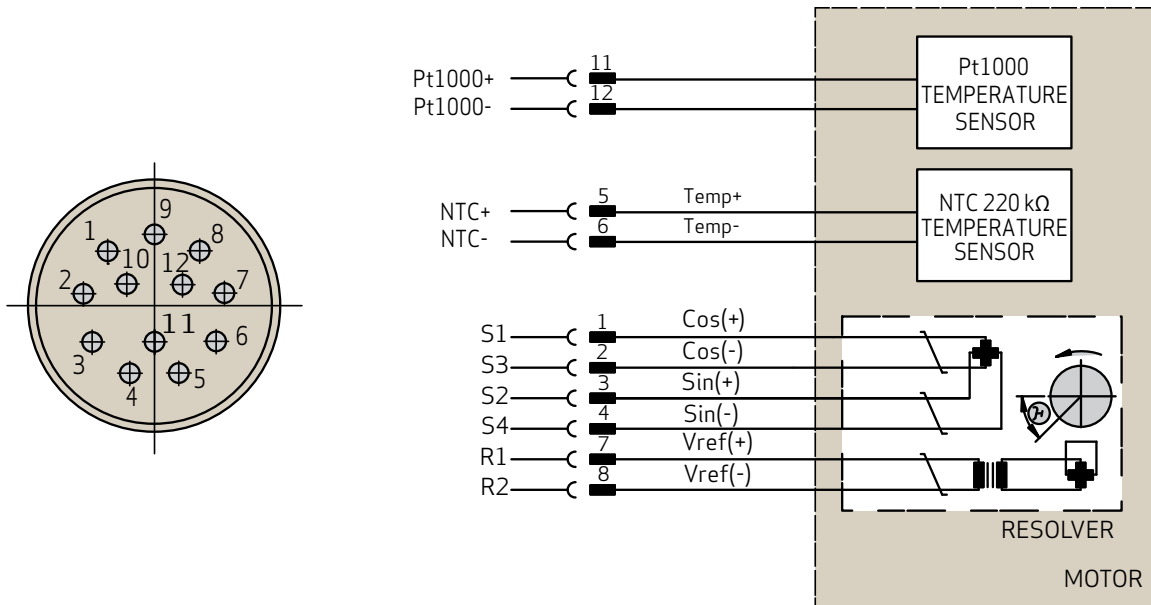

Fan Connector

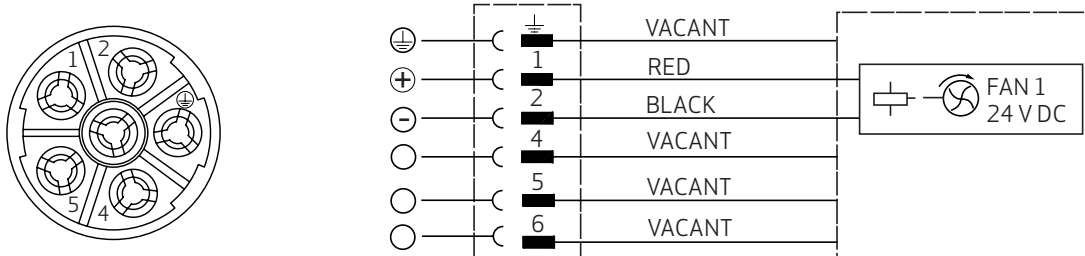

Calculations

$$M = \frac{V \cdot \Delta p}{2\pi \cdot 10}$$

M [Nm] = Torque
 V [cm³] = Displacement
 Δp [bar] = Pressure difference
 P_A - P_B

$$n = \frac{Q \cdot 1,000}{V}$$

n [rpm] = Speed
 Q [l/min] = Flow

ELECTRICAL INTERFACES

Motor Power Cables



Ordering number	CB05708-001-yyy ¹⁾²⁾		CA44958-001-yyy ¹⁾²⁾		CB00076-001-yyy ¹⁾²⁾		CA98676-001-yyy ¹⁾²⁾	
Continuous rated current ³⁾	25 A		44 A		61 A		75 A	
Cable cross-section	4 x 4 mm ² + 2 x 1.5 mm ²		4 x 6 mm ² + 2 x 1.5 mm ²		4 x 10 mm ² + 2 x 1.5 mm ²		4 x 16 mm ² + 2 x 1.5 mm ²	
Temperature range ³⁾	-50 to +80 °C (-58 to 194 °F)		-50 to +80 °C (-58 to 194 °F)		-50 to +80 °C (-58 to 194 °F)		-50 to +80 °C (-58 to 194 °F)	
Wiring	Connector pin	Wiring	Connector pin	Wiring	Connector pin	Wiring	Connector pin	Wiring
	2	U	U	U	U	U	U	U
	4	VV	V	VV	V	VV	V	VV
	1	WWW	W	WWW	W	WWW	W	WWW
	PE	Yellow / green	PE	Yellow / green	PE	Yellow / green	PE	Yellow / green
	5	N. c. / white	+	N. c. / white	+	N. c. / white	+	N. c. / white
	6	N. c. / black	-	N. c. / black	-	N. c. / black	-	N. c. / black
Connector housing	Screen	Connector housing	Screen	Connector housing	Screen	Connector housing	Screen	
Connector type	Size 1		Size 1.5					

Ordering number connector only	C08365-002	CA37698-001	CA37698-002
-----------------------------------	------------	-------------	-------------

- 1) 001 for standard configuration option, others upon request.
- 2) yyy stands for length in meters. Standard length: 1 m, 5 m, 10 m, 15 m, 20 m, 50 m. Further lengths upon request.
- 3) Installation type: fixed. Maximum current carrying capacity at 30 °C (following DIN VDE 0298-4). The final maximum current carrying capacity depends, among other things, on the ambient conditions, the type of installation and the number of loaded cores.

ELECTRICAL INTERFACES

Resolver Feedback Cables



Ordering number	C08335-013-yyy ¹⁾	CC75041-002-yyy ¹⁾
Motor feedback system	Resolver, NTC temperature sensor	Resolver, Pt1000 temperature sensor
Cable-end assignment	Sub-D 9pol	Open end
Configuration		
Capable for energy chains	Yes	
Minimum bend radius	90 mm	
Temperature range	-40 to +85 °C	
Cable diameter approximately	8.8 mm	
Material of outer sheath	Polyurethane	
Resistance	Resistant to oil, hydrolysis and microbic attack (VDE0472)	
Approvals	UL-Style 20233,+80 °C -300 V CSA-C22.2N.210-M90, +75 °C -300 V FT1	

Ordering number connector only	CA46373-001
---------------------------------------	--------------------

1) yyy stands for length in meters. Standard length: 1 m, 5 m, 10 m, 15 m, 20 m, 50 m. Further lengths upon request.

ORIENTATION OF ELECTRICAL CONNECTORS AND LIQUID COOLING PORTS EPU-G Sizes 13 and 20

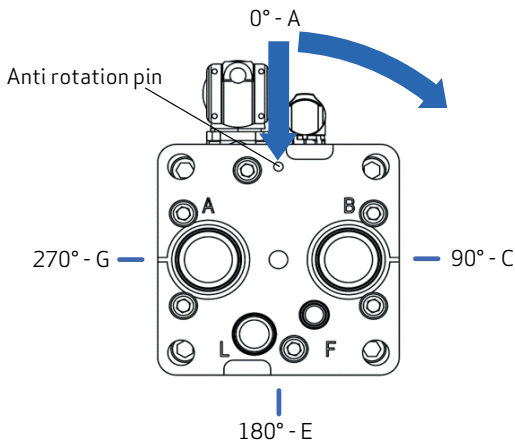

Note:

- Angle starts on anti-rotation pin
- Natural and fan cooled options use Z in model number pos. 12
- Angle between electrical and liquid cooling ports is fixed at -90°

Available Connector Orientations

Convection Cooling

										A	Z	C	Z	E	Z	G	Z		
x	EPU	005	x	x	GP	x0	C	xx		■	■	□	□	□	□	□	□	□	...
x	EPU	008	x	x	GP	x0	C	xx		■	■	□	□	□	□	□	□	□	...
x	EPU	013	x	x	GP	x0	C	xx		■	■	□	□	□	□	□	□	□	...
x	EPU	020	x	x	GP	x0	C	xx		■	■	□	□	□	□	□	□	□	...

Fan Cooling

										A	Z	C	Z	E	Z	G	Z		
x	EPU	005	x	x	GP	x0	F	xx		■	■	□	□	□	□	□	□	□	...
x	EPU	008	x	x	GP	x0	F	xx		■	■	□	□	□	□	□	□	□	...
x	EPU	013	x	x	GP	x0	F	xx		■	■	□	□	□	□	□	□	□	...
x	EPU	020	x	x	GP	x0	F	xx		■	■	□	□	□	□	□	□	□	...

Water Cooling

										A	G	C	A	E	C	G	E		
x	EPU	005	A	x	GP	x0	W	xx		■	■	□	□	□	□	□	□	□	...
x	EPU	008	A	x	GP	x0	W	xx		■	■	□	□	□	□	□	□	□	...
x	EPU	013	A	x	GP	x0	W	xx		■	■	□	□	□	□	□	□	□	...
x	EPU	020	A	x	GP	x0	W	xx		■	■	□	□	□	□	□	□	□	...
x	EPU	005	F	x	GP	x0	W	xx		■	■	□	□	□	□			...	
x	EPU	008	F	x	GP	x0	W	xx		■	■	□	□	□	□			...	
x	EPU	013	F	x	GP	x0	W	xx		■	■	□	□	□	□			...	
x	EPU	020	F	x	GP	x0	W	xx		■	■	□	□	□	□			...	

- Standard option
- Available option

ORIENTATION OF ELECTRICAL CONNECTORS AND LIQUID COOLING PORTS

EPU Sizes 19 to 140

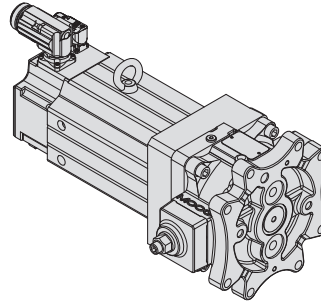
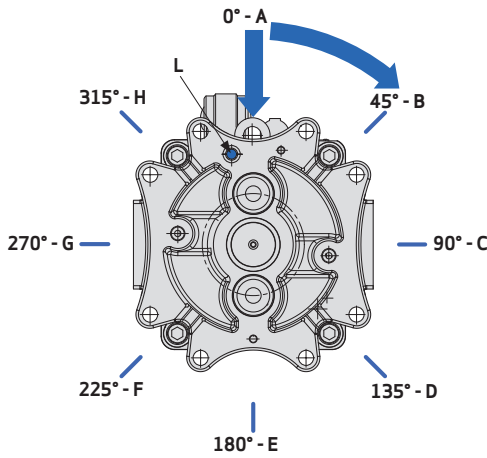

Note: • Angle starts on port L
 • Natural and fan cooled options use Z in model number pos. 12
 • Angle between electrical and liquid cooling ports is fixed at -90°

Example shows:
 Connector orientation = A,
 Cooling connection = G

Available Connector Orientations

Natural Cooling

												A	Z	B	Z	C	Z	D	Z	E	Z	F	Z	G	Z	H	Z	
x	EPU	019	x	x	xx	S0	C	x	x	■	■							□	□								...	
x	EPU	019	x	x	xx	M0	C	x	x			□	□					□	□						■	■	...	
x	EPU	019	x	x	xx	H0	C	x	x			□	□					□	□						■	■	...	
x	EPU	032	x	x	xx	xx	C	x	x	■	■			□	□			□	□					□	□		...	
x	EPU	080	x	x	xx	xx	C	x	x	■	■			□	□			□	□					□	□		...	
x	EPU	140	x	x	xx	xx	C	x	x	■	■			□	□			□	□					□	□		...	

Fan Cooling

												A	Z	B	Z	C	Z	D	Z	E	Z	F	Z	G	Z	H	Z	
x	EPU	019	x	x	xx	S0	F	x	x	■	■							□	□								...	
x	EPU	019	x	x	xx	M0	F	x	x	■	■							□	□								...	
x	EPU	019	x	x	xx	H0	F	x	x			□	□					□	□						■	■	...	
x	EPU	032	x	x	xx	xx	F	x	x	■	■			□	□			□	□					□	□		...	
x	EPU	080	x	x	xx	xx	F	x	x	■	■			□	□			□	□					□	□		...	
x	EPU	140	x	x	xx	xx	F	x	x	■	■			□	□			□	□					□	□		...	

Liquid Cooling

												A	G	C	A	E	C	G	E	
x	EPU	019	x	x	xx	xx	W	x	x	■	■			□	□				...	
x	EPU	032	x	x	xx	xx	W	x	x	■	■			□	□				...	
x	EPU	080	x	x	xx	xx	W	x	x	■	■	□	□	□	□	□	□		...	
x	EPU	140	x	x	xx	xx	W	x	x	■	■	□	□	□	□	□	□		...	

- Standard option
- Available option

ORDERING CODE

Sizes 13 and 20 with Internal Gear Pump

Model Number (assigned at the factory)	Type Designation												
	1	2	3	4	5	6	7	8	9	10	11	12	13
	S	EPU			D	GP			S				1
1 Product division													13 Feedback option
S Standard													1 2-poles resolver
2 Product type													12 Cooling connection (liquid cooling)
EPU Electrohydrostatic Pump Unit with internal gear pump													A 0°
													C 90°
													E 180°
													G 270°
													Z Not liquid cooled
3 Nominal displacement pump													11 Connector orientation
013 13 cm ³ (0.79 in ³)													A 0°
020 20 cm ³ (1.22 in ³)													C 90°
													E 180°
													G 270°
4 Mounting options													10 Electrical connection
A Axial													3 Angle rotatable
F Footbracket													4 Cable box
5 Fluid													9 Motor construction
D Mineral oil. HFD													S Sealing
6 Pump options													8 Cooling
GP Internal gear pump													C Natural cooling
													F Fan cooling
													W Liquid cooling
7 Performance class													
S0 Small performance class													
M0 Medium performance class													
H0 High performance class													

The Electrohydrostatic Pump Unit is delivered with seal kit to the manifold.

ORDERING CODE

Sizes 19 to 140 with Radial Piston Pump

Model Number (assigned at the factory)	Type Designation														
	1	2	3	4	5	6	7	8	9	10	11	12	13	14	15
	S	EPU			D				S				1	-	/
1 Product division															
S Standard															
2 Product type															
EPU Electrohydrostatic Pump Unit															
3 Nominal displacement pump															
019 19 cm ³ (1.16 in ³)															
032 32 cm ³ (1.95 in ³)															
080 80 cm ³ (4.88 in ³)															
140 140 cm ³ (8.54 in ³)															
4 Pump ports															
A 2 operating ports (for half-open system)															
P 2 operating ports (for self-contained system)															
5 Fluid															
D Mineral oil. HFD															
6 Controllers															
B1 Mechanical stroke adjustment (V = constant)															
N1 Dual displacement															
7 Performance class															
S0 Small performance class															
M0 Medium performance class															
H0 High performance class															
8 Cooling															
C Natural cooling															
F Fan cooling															
W Liquid cooling															
9 Motor construction															
S Sealing															
10 Electrical connection															
3 Angle rotatable															
4 Cable box															
11 Connector Orientation															
See chapter "Orientation of Electrical Connectors and Liquid Cooling Ports"															
12 Cooling connection (liquid cooling)															
Z Not liquid cooled															
13 Feedback option															
1 2-poles resolver															
14 Maximum displacement V_{max}															
XXX V _{max} (see table below)															
15 Minimum displacement V_{min}															
YYY V _{min} (see table below)															
000 Controller B1 (V = constant)															

The Electrohydrostatic Pump Unit is delivered with seal kit to the manifold

V_{max} and V_{min} Options for Ordering Code (Positions 14, 15)

Nominal displacement V _n [cm ³]	Maximum displacement V _{max} [cm ³]	Ratio V _n /V _{min}						
		1.5	2	2.5	3	4		
		Minimum displacement V _{min} [cm ³]						
019	019	015	010	013	010	008	006	005
032	032	028	024	021	016	013	011	008
080	080	064	048	053	040	032	027	020
140	140	120	100	093	070	056	047	035

Standard option

NOTES

MORE PRODUCTS. MORE SUPPORT.

Moog designs a range of motion control products to complement those featured in this document. Moog also provides service and support for all of our products. For more information, contact the Moog facility closest to you.

Australia
+61 3 9561 6044
Service + 61 3 8545 2140
info.australia@moog.com
service.australia@moog.com

Brazil
+55 11 3572 0400
info.brazil@moog.com
service.brazil@moog.com

Canada
+1 716 652 2000
info.canada@moog.com

China
+86 512 5350 3600
info.china@moog.com
service.china@moog.com

France
+33 1 4560 7000
Service +33 1 4560 7015
info.france@moog.com
service.france@moog.com

Germany
+49 7031 622 0
Service +49 7031 622 197
info.germany@moog.com
service.germany@moog.com

Hong Kong
+852 2 635 3200
info.hongkong@moog.com

India
+91 80 4057 6666
Service +91 80 4057 6604
info.india@moog.com
service.india@moog.com

Ireland
+353 21 451 9000
info.ireland@moog.com

Italy
+39 0332 421 111
Service 800 815 692
info.italy@moog.com
service.italy@moog.com

Japan
+81 46 355 3767
info.japan@moog.com
service.japan@moog.com

Korea
+82 31 764 6711
info.korea@moog.com
service.korea@moog.com

The Netherlands
+31 252 462 000
info.thenetherlands@moog.com
service.netherlands@moog.com

Singapore
+65 677 36238
Service +65 651 37889
info.singapore@moog.com
service.singapore@moog.com

Spain
+34 902 133 240
info.spain@moog.com

Sweden
+46 31 680 060
info.sweden@moog.com

Turkey
+90 216 663 6020
info.turkey@moog.com

United Kingdom
+44 (0) 1684 858000
Service +44 (0) 1684 278369
info.uk@moog.com
service.uk@moog.com

USA
+1 716 652 2000
info.usa@moog.com
service.usa@moog.com

For product information, visit www.moog.com/industrial

Moog is a registered trademark of Moog Inc. and its subsidiaries.
All trademarks as indicated herein are the property of Moog Inc. and its subsidiaries.
©2026 Moog Inc. All rights reserved. All changes are reserved.

Electrohydrostatic Pump Unit
KEM, Rev. L, February 2026, Id. CDL49052-en