

PROPORTIONAL VALVES

SERIES D941

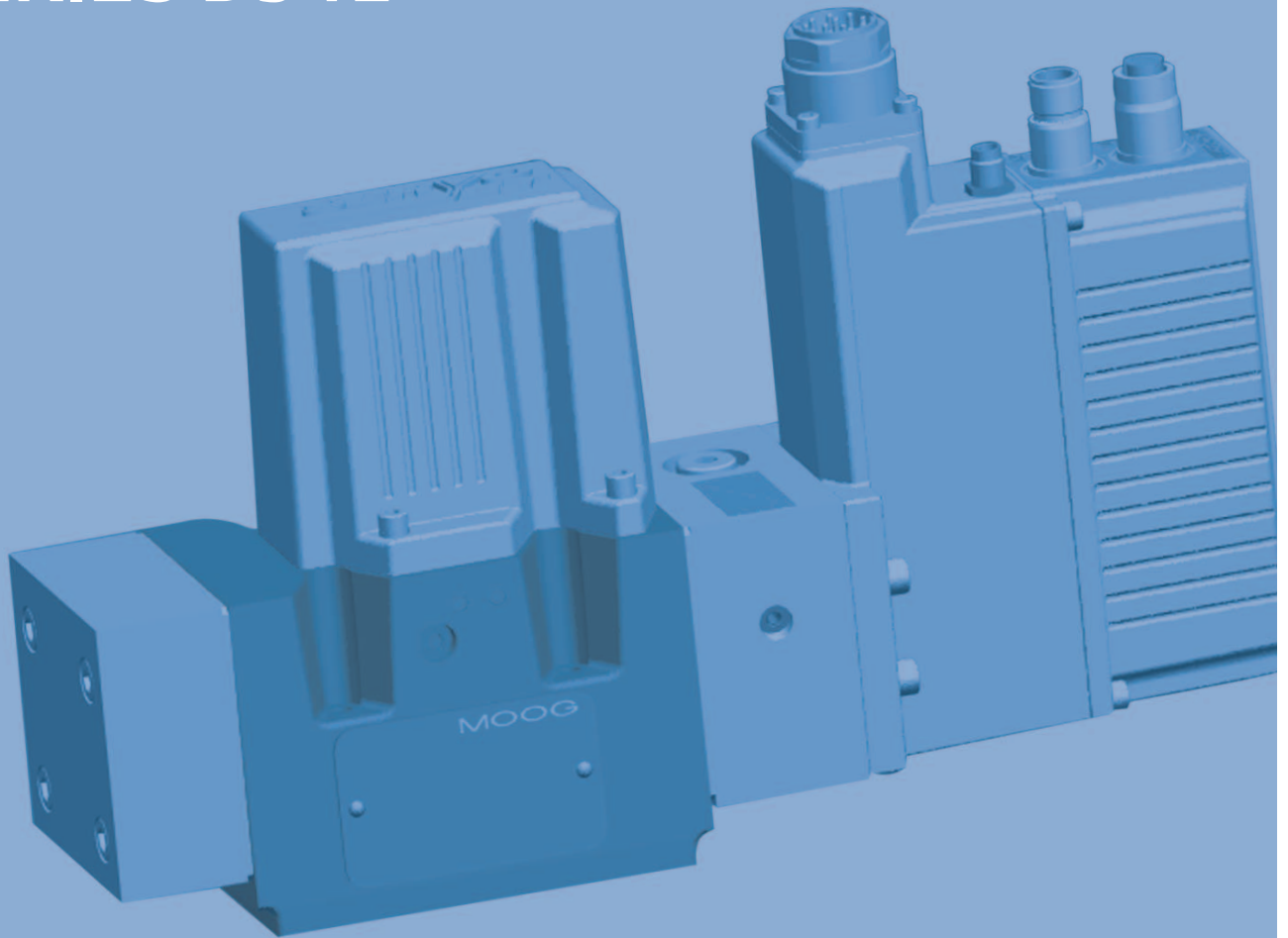

A TWO STAGE pQ-PROPORTIONAL VALVES
WITH SERVOJET®-PILOT STAGE
INTEGRATED DIGITAL ELECTRONICS
AND OPTIONAL FIELD BUS INTERFACE

CHAPTER	PAGE	EXCELLENCE IN MOTION CONTROL TECHNOLOGY
General overview	2	For over 50 years Moog has ranked amongst the leading providers of motion control technology with a focus on the production and application of high performance products. Today, Moog offers innovative products using state of the art control technology that contributes to improvements in the performance of machines.
Characteristics and benefits	3	
Functional description	4	
Operating modes	5	
Electronics	7	MOOG SERVO- AND PROPORTIONAL VALVES
Hydraulics w/Field Bus	10	Moog in Germany has been producing servo- and proportional valves with integrated electronics for over 30 years. During this period, more than 400,000 valves have been delivered. Our servo- and proportional valves are successfully used in all kinds of applications in machine and plant construction.
Configuration Software	11	
Technical data	12	TWO-STAGE pQ-PROPORTIONAL VALVES WITH A SERVOJET®-PILOT STAGE
Performance curves	13	The pQ-proportional valves of the D941 series are throttle valves for 2x2-, 3-, 4- or even 5-way applications.
Installation drawings	14	
Fail-safe electronics	16	The pQ-valves control flow and regulate pressure (upper or lower limiting pressure). Thus, they can be used for both pressure regulation as well as applying a pressure-limit. The regulating electronics for the spool position and the pressure are integrated in the valve as is a pressure sensor.
Fail-safe installation drawing	18	
Accessories	19	
Ordering information	20	The valves have been continuously improved. The Jetpipe pilot stage is based on the steel pipe principle which has proved itself in various series of Moog valves over the past 15 years. The Jetpipe has been further developed into the ServoJet®-pilot stage.
Global support	23	

Our Quality Management System conforms to DIN EN ISO 9001.

NOTICE

This catalog is for users with technical knowledge. To ensure that all necessary characteristics for function and safety of the system are covered, the user must check the suitability of the products described herein. Product descriptions provided herein are subject to changes that may be applied without prior notification. In case of doubt, please contact Moog.

Moog is a registered trademark of Moog Inc. and its subsidiaries. Unless stated otherwise, all trademarks mentioned herein are the property of Moog Inc. and its subsidiaries. For the full disclaimer refer to www.moog.com/literature/disclaimers.

©Moog Inc. 2006. All rights reserved. Changes reserved

For the most current information, visit www.moog.com/industrial

- Before commissioning, the complete hydraulic system must be flushed and the hydraulic fluid must be filtered.
- Please read the notes in the section entitled "Electronics", page 7
- In the same way as new valves, repaired valves / exchanged valves will be shipped with factory default settings.
- Prior to commissioning the valves, check for the correct configuration and any potentially changed parameters.

Q-, p-, pQ-FUNCTIONALITY

The valves offer full pQ-functionality and may be toggled between flow control and/or operating pressure control. Using the pQ-function, volume control and pressure control are available using a single proportional valve. The commutation takes place according to the parameterization via the Field Bus interface.

DIGITAL ELECTRONICS

The digital driver and control electronics are integrated into the valve. The valve electronics contain a microprocessor system which performs all important functions via the valve software it contains. The digital electronics enable the valve to be controlled across the entire working range.

FIELD BUS INTERFACE

The valves are parameterized, activated, and monitored via the built-in Field Bus interface (CANopen, Profibus DP V1 or

EtherCAT). To reduce wiring, the Field Bus interface is provided with two plugs.

Thus, valves may be integrated into the bus without any external T-joints. In addition, up to two analog input commands and up to two analog actual value outputs are available.

Optionally, the valves are available without a Field Bus interface. In this case, the valve is controlled using analog inputs. Valve parameters are set using the integrated service socket.

DIGITAL ELECTRONICS

In addition to internal parameters such as pressure and volume flow, the valves are capable of controlling external signals such as position, speed, force etc. The active axis controllers may change as a result of defined events.

Our application engineers will be happy to assist you.

BENEFITS OF THE DIGITAL pQ-PROPORTIONAL VALVES D941 SERIES

- Field Bus data connection: electrically separated Field Bus-interface
- Diagnosis options: Integrated monitoring of the most important environmental and internet parameters; valve parameters may be changed on site or remotely.
- Flexibility: Since parameters may be downloaded using the Field Bus or the superior PLC-program, valve parameter may be tuned during a machine cycle on an operating machine.
- Pressure control configuration: up to 16 configurations may be saved and can be activated during operation.
- Superior control: The improved frequency response of this version allows high closed-loop position loop gain, providing excellent static and dynamic response and a superior

control system performance. The improved valve dynamic performance is due to the extremely high natural frequency of the ServoJet®-pilot stage (500 Hz) and the implementation of advanced control algorithms, which is only possible with digital electronics.

- Reliability: The high pressure recovery of the ServoJet®-pilot stage (up to 80 % Δp at 100 % control signal) provides higher spool driving forces and ensures enhanced spool position repeatability.
- Safety: Fail-safe versions with a defined safe spool position using a spring or by an external supply cut off ensure operator safety.

TWO-STAGE DIGITAL pQ-PROPORTIONAL VALVE D941 SERIES

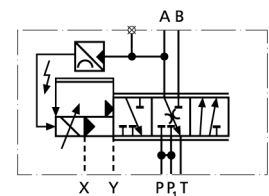
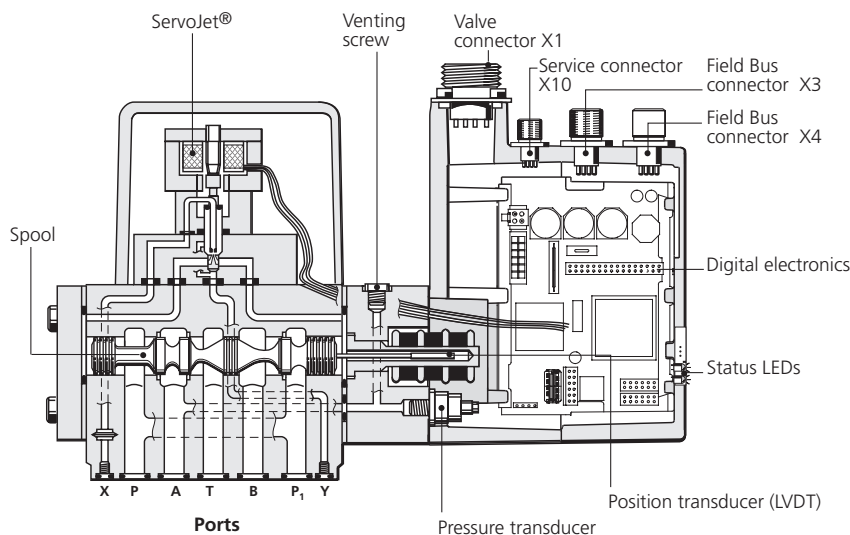

Hydraulic Symbol:

Symbol shown with pilot pressure and 24 V DC electric supply

SERVOJET®-PILOT STAGE

PRINCIPLE OF THE SERVOJET®-PILOT STAGE

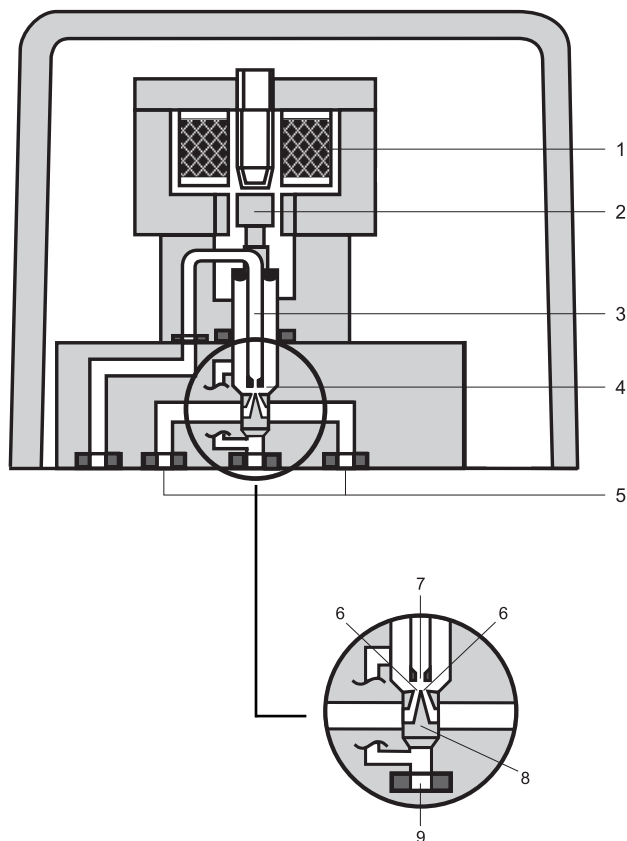

FUNCTION OF THE SERVOJET®-PILOT STAGE

The ServoJet®-pilot stage is an improvement of the Jetpipe-pilot stage using the jet pipe principle. It consists of torque motor, jet pipe and manifold.

An electrical current through coil (pos. 1) of the ServoJet®-pilot stage causes the anchor (pos. 2) with the jet pipe (pos. 3) to move. The linked and compressed (by a special nozzle design) fluid jet hits one of the two valve openings (pos. 8) with a greater impact than the other.

This causes a pressure difference in the control connections (pos. 5) of the ServoJet®-pilot stage. The resulting volume flow moves the control spool of the main stage in the respective working direction (see picture, page 3). Return flow is via the annular space (pos. 4) below the nozzle to the return port (pos. 9)

POS.	DESCRIPTION
1	Coil
2	Anchor
3	Jetpipe
4	Annular space below the nozzle
5	Control connections
6	Receiving Orifice's
7	Nozzle
8	Receiver
9	Return Port

3-way valve in main line

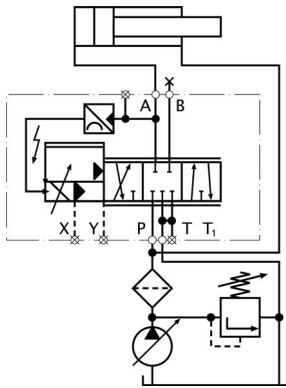

Optional X and Y external

The device operates as a 3-way pressure reducing valve with flow from P → A or A → T. Only one load port is used.

5-way valve in main line

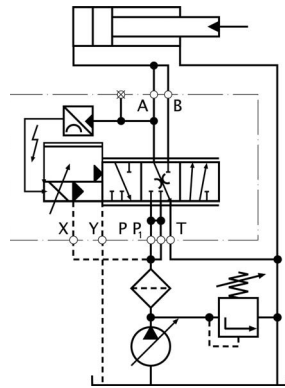

Only with X and Y external P- and T-ports interchanged (does not conform to ISO 4401)

The device operates like the 3-way pQ-valve but with a doubled flow rate applied to the load. A directional change in the motion of the load requires an external force.

4-way valve in main line

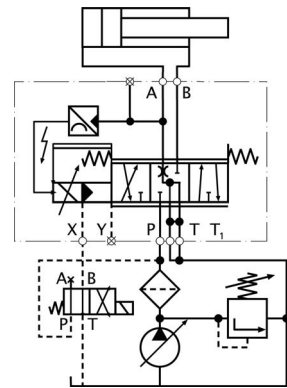

Optional Y external

From P → A the valve operates like a 3-way pQ-valve. From P → B it allows only flow modulation. By this means the direction of the load motion can be reversed (open loop velocity control for load retract).

2x2-way valve in bypass line

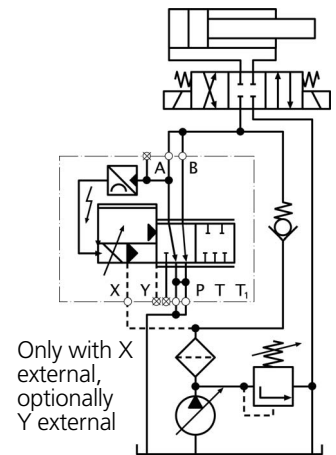

Only with X external, optionally Y external

The device has parallel flow paths and operates as an electrically adjustable pressure relief valve from A → T and B → T1, respectively. At zero command signal the valve is fully open, i.e. the pressure in the load ports is zero apart from minor pressure build up due to line leakage. A minimum pilot pressure ($p_x > 25$ bar (357.25 psi)) has to be imposed. This can be achieved by a check valve with a 25 bar (357.25 psi) cracking pressure (as shown) or by a separate pilot supply pump.

PILOT PRESSURE

If large flows are required together with a high pressure drop across the valve, a sufficiently high pilot pressure has to be provided to overcome the jet forces. The following approximation holds for the pilot pressure p_x :

$$p_x \geq 8,5 \cdot 10^{-3} \cdot Q \cdot \sqrt{\Delta p}$$

p_x [bar] = pilot pressure
 Q [l/min] = max. flow
 Δp [bar] = actual pressure drop per control edge

The pilot pressure p_x must exceed the return pressure of the ServoJet®-pilot stage by at least 25 bar (357.25 psi).

VENTING OF PRESSURE TRANSDUCER

Prior to first operation of the valve the internal lines of the pressure transducer must be carefully vented. When selecting the installation position of the valve care must be taken that the bleeding screw can become effective.

If the load is located higher than the pQ-Valve the load also must be vented at its highest point.

Attention: Vent only at reduced pressure! Danger of injury!

OPERATING MODES OF THE PROPORTIONAL VALVE

FLOW CONTROL (Q-CONTROL)

In this operating mode of the proportional valve, the spool position is controlled. The predefined command signal is proportional to a particular spool position.

The command signal (spool position command) is fed to the valve electronics. A position transducer (LVDT) measures the spool's actual position and forwards this information to the valve electronics. The electronic system compares the actual spool position and the command signal, and generates a signal to drive the ServoJet®-pilot stage, which then brings the spool into the correct position.

The position command can be influenced by parameters in the valve software (ie: linearization, ramping, dead band, sectionally defined amplification, etc).

PRESSURE CONTROL (p-CONTROL)

In this operating mode of the proportional valve, the pressure in port A is controlled. The predefined command signal corresponds to a particular pressure in port A. The command signal (pressure command in port A) is transmitted to the valve electronics. A pressure transducer measures the pressure in port A and feeds this to the valve electronics.

The electronic system compares the actual pressure signal and the command signal and generates a signal to drive the ServoJet®-pilot stage, which then brings the spool into the correct position.

The pressure control function can be influenced by parameters in the valve software (ie. ramping etc.). The pressure regulator functions as an extended PID controller. In the valve software, you can set the parameters of the PID controller.

FLOW CONTROL AND PRESSURE CONTROL (pQ-CONTROL)

This is a combination of flow and pressure control for which both command signals (flow and pressure) must be present. During the pQ-function, the command position calculated by the pressure controller is compared to the command position computed externally. The smaller of these is fed into the position control loop.

The following are examples of possible combinations:

- Flow control with pressure limiting control
- Forced changeover from one operating mode to the other

VALVE FLOW CALCULATIONS

The actual valve flow is dependent on the spool and the pressure drop Δp across the spool ends.

For a flow command value of 100% a rated pressure drop of $\Delta p_N = 5 \text{ bar}$ (71.45 psi) per control edge results in a rated flow Q_N . For other than the rated pressure drop the valve flow changes at a constant command signal according to the following formula.

$$Q = Q_N \cdot \sqrt{\frac{\Delta p}{\Delta p_N}}$$

Q [l/min] = calculated flow
 Q_N [l/min] = rated flow
 Δp [bar] = actual valve pressure drop
 Δp_N [bar] = rated valve pressure drop

The actual valve flow Q must not exceed a mean velocity of 30m/s (96.54 ft/s) in the orifices P, A, B and T.

VOLUME FLOW DIAGRAM (4-WAY-FUNCTION)

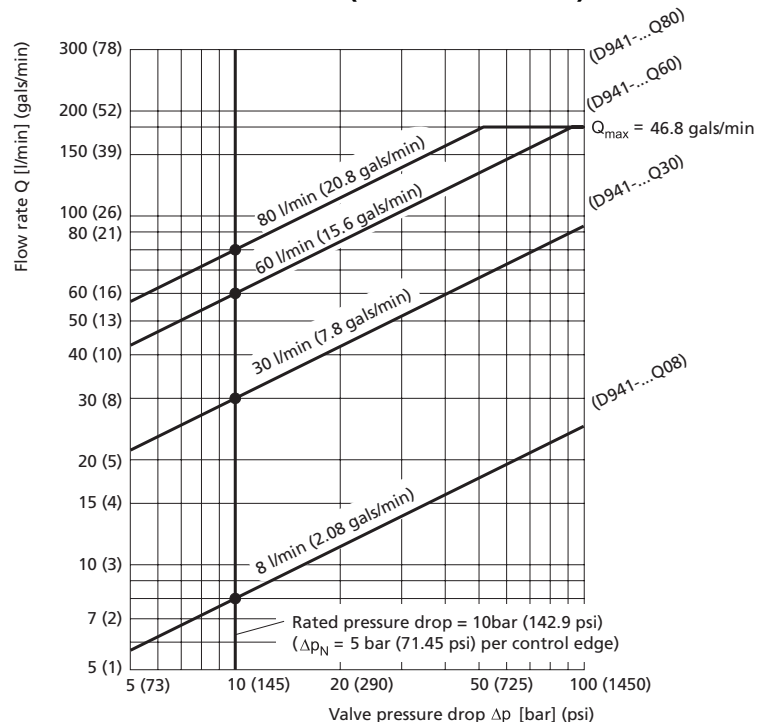

GENERAL REQUIREMENTS FOR VALVE ELECTRONICS

- Supply 24 V DC, min. 18 V DC, max. 32 V DC; current max. 350 mA for valve electronics. Additional supply 24 V DC for electrical failsafe valve and current 1.2A on pin 1 ➔ 2
- All signal lines, including those of external transducers, shielded.
- Shielding connected radially to \perp (0 V), power supply side, and connected to the mating connector housing (EMC).
- **EMC:** Meets the requirements of immunity: DIN EN 61000-6-2:2005 (criterion A) and emission according to DIN EN 61000-6-4:2005 (EtherCAT according to DIN EN 61000-6-3:2005).
- External fusing 0.5 A slow blow.
- Duty cycle 100 %
- Max. power consumption 8.4 W (350 mA at 24 V DC)
- Minimal cross-section PE-line $\geq 0,75 \text{ mm}^2$ (0.03 in²), other signal lines $\geq 0.25 \text{ mm}^2$ (0.01 in²).
- Consider voltage losses between cabinet and valve
- See also Moog technical note TN 494.
- Note: When making electrical connections to the valve (shield, \perp) appropriate measures must be taken to ensure that locally different ground potentials do not result in excessive currents to ground
- See also Moog technical note TN 353.

SIGNALS AND WIRING FOR VALVES WITH ANALOGUE ACTIVATION/CONTROL DRIVE POSSIBILITIES

Valves with current command input
Command signal 0 to 10 mA (p func.), floating
Command signal 0 to \pm 10 mA (Q func.), floating

The spool stroke of the valve for the volume flow function is proportional $I_4 = - I_5$ (at $I_7 = 0$).
 The command signal $I_4 = +10 \text{ mA}$ equals 100 % valve opening $P \rightarrow A$ and $B \rightarrow T$.
 At 0 mA command the spool is in the central position.
 In the pressure function (0 to 10 mA), the pressure is proportional at port A of the valve $I_7 = - I_5$ (at $I_4 = 0 \text{ mA}$).
 $I_7 = +10 \text{ mA}$ equals 100 % regulated pressure in port A.

Command signal 4 to 20 mA (p funct.), floating
Command signal 4 to \pm 20 mA (Q funct.), floating

The spool stroke of the valve for the volume flow function is proportional $I_4 = - I_5$ (at $I_7 = 0$).
 The command signal $I_4 = 20 \text{ mA}$ equals 100 % valve opening $P \rightarrow A$ and $B \rightarrow T$.
 At 12 mA command the spool is in the central position. In pressure function (4 to 20 mA), the pressure is proportional at port A of the valve $I_7 = - I_5$ (at $I_4 = 0 \text{ mA}$).
 $I_7 = + 20 \text{ mA}$ equals 100 % regulated pressure in port A.

Valves for voltage control
Command signal 0 to 10 V (p funct.), floating
Command signal 0 to \pm 10 V (Q funct.), floating

The spool stroke of the valve at volume flow function is proportional $(U_4 - U_5)$. The command signal $(U_4 - U_5) = +10 \text{ V}$ equals 100 % valve opening $P \rightarrow A$ and $B \rightarrow T$.
 For 0 V command the spool is in the central position. In the p-function (0 to 10 V) the pressure in port A of the valve is proportional to $(U_7 - U_5)$.
 $(U_7 - U_5) = + 10 \text{ V}$ equals 100 % regulated pressure in port A.

Actual value 4 to 20 mA

The actual spool position value for flow volume resp. pressure at port A at pressure function, can be measured at 6 and 8 (see diagram below). These signals can be used for monitoring and fault detection purposes. The spool stroke resp. pressure range corresponds 4 to 20 mA. At 12 mA command the spool is in the central position. 20 mA equals 100% valve opening $P \rightarrow A$ und $B \rightarrow T$.

The position signal output 4 to 20 mA allows the detection of a cable break when $I_{out} = 0 \text{ mA}$.

Circuit diagram for measurement of actual value I_{out} (position of spool) and I_8 (pressure in port A) for valves

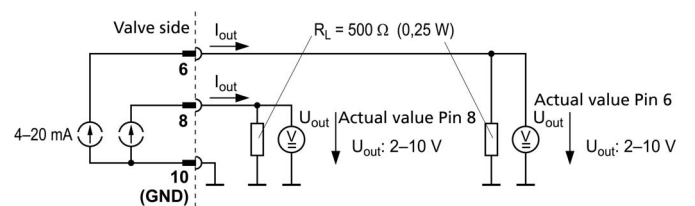

Note: Enable input

With enable signal of $< 6.5 \text{ V}$ the main spool will move to a safe position. Options:

- Defined centered position, spool position $\pm 3\%$ (unbiased pilot valve) Enable function A¹⁾
- End position (biased pilot valve). Enable function B¹⁾

¹⁾ see type key pages 20 and 21

WIRING FOR VALVES WITH 11+PE-POLE CONNECTOR X1

To EN 175201 part 804, mating connector (metal) with leading protective ground connection (⊕).

Pin	Function	Signal	Voltage floating ±10 V, 0 to 10 V	Current floating ±10 mA, 0 to 10 mA, 4 to 20 mA ¹⁾
1	Not used			
2	Not used			
3	Enable input		8,5 bis 32 V DC above GND: operation of the proportional valve enabled < 6,5 V DC above GND: Valve fail-safe condition	
4	Command input Flow function		$U_{in} = U_{4-5}$ $R_{in} = 20 \text{ k}\Omega$	$I_{in} = I_4 = -I_5$ (for $I_7=0$) ²⁾ $R_{in} = 200 \Omega$
5	Reference point Input rated command		Reference to ground for pin 4 and 7	common feedback for pin 4 and 7
6	Actual value output spool position		$I_{out} = 4$ to 20 mA based on GND (I_{out} is proportional to the spool position; the output is short circuit protected; for actual value output conversion I_{out} see page 6); $R_L = 0$ to 500 Ω	
7	Command input pressure function		$U_{in} = U_{7-5}$ $R_{in} = 20 \text{ k}\Omega$	$I_{in} = I_7 = -I_5$ (for $I_4=0$) ²⁾ $R_{in} = 200 \Omega$
8	Actual value output pressure		$I_{out} = 4$ to 20 mA referenced to GND (I_{out} proportional to the pressure in port A); the output is short circuit protected; for conversion of the actual value signal I_{out} see page 6); $R_L = 0$ to 500 Ω	
9	Supply Voltage		24 V DC (18 to 32 V DC) above GND	
10	Power ground		GND	
11	Digital output		Error monitoring ³⁾	
⊕	Protective conductor contact			

The potential differences between pins 4, 5 and 7 (measured against pin 10) each must be between -15 and +32 V.

1) Command signals $I_{in} < 3 \text{ mA}$ (due to cable break, for example) indicate a defect for signals 4 to 20 mA. The valve reaction to this defect may be customized and activated by the customer.

2) As pin 5 is the common feedback for pin 4 and pin 7, $-I_5 = I_4 + I_7$ applies.

3) Output may be factory programmed, "low" means error. (e.g. difference between command value and actual value)

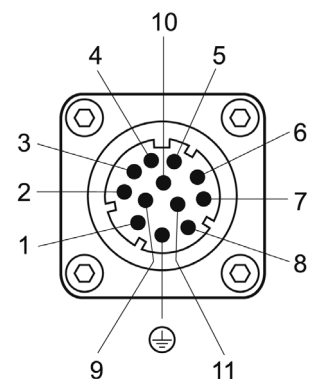

CAN-IN/OUT-MOUNTED CONNECTOR (X3, X4 / CODING A / 2 X M12X1 / 5-POLE)

Pin	Signal X3, X4	
1	CAN_SHLD	Shield
2	CAN_V+	not connected in the valve
3	CAN_GND	Ground
4	CAN_H	Transceiver H
5	CAN_L	Transceiver L

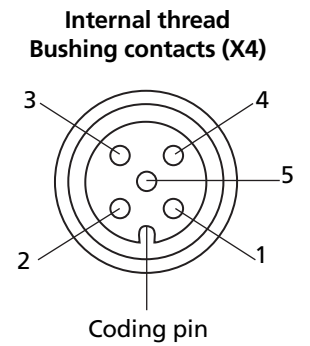
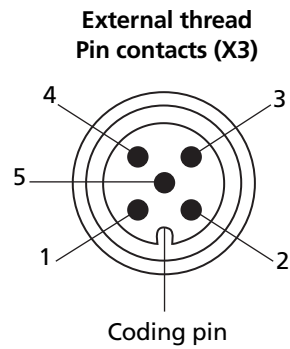

CAN-IN/OUT-MOUNTED CONNECTOR (X3, X4 / CODING B / 2 X M12X1 / 5-POLE)

Pin	Signal X3, X4	
1	Profi V+	Supply voltage 5 V of terminating resistors
2	Profi A	Receiving/sending data -
3	Profi GND	Ground
4	Profi B	Receiving/sending data +
5	Shield	Shield

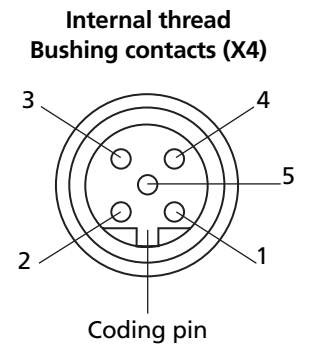
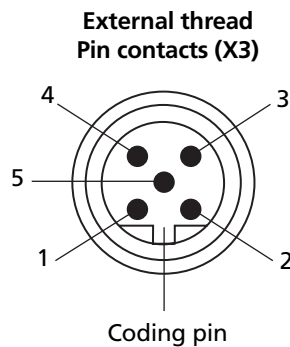

ETHERCAT-IN/OUT CONNECTOR (X3, X4 / CODING D / 2 X M12X1 / 4-POLE)

Pin	Signal X4 IN	Signal X3 OUT
1	TX + IN	TX + OUT
2	RX + IN	RX + OUT
3	TX - IN	TX - OUT
4	RX - IN	RX - OUT

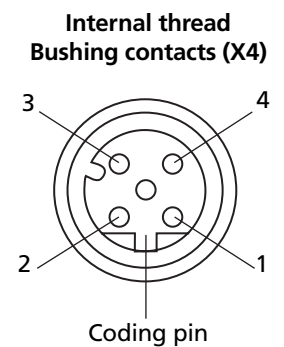
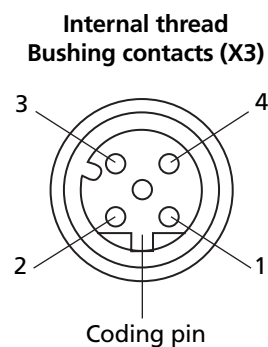

GENERAL

Modern automation technology is characterized by an increasing decentralization of processing functions via serial data communication systems. The use of serial bus systems instead of conventional communication technology ensures the increased flexibility of systems in terms of modifications and expansions.

It also has a tremendous potential for savings in project and installation costs in many areas of industrial automation. Among the benefits that have become viable through the use of Field Bus are additional options for parameterization, enhanced diagnosis options and the reduction of variants.

VDMA PROFILE

In one working group within the German Machinery and Plant Manufacturers' Association, a VDMA profile was created in collaboration with numerous well-known hydraulic system manufacturers. This profile describes communication

between hydraulic components via a Field Bus. It defines uniform functions and parameters in a standardized exchange format.

CANopen

According to EN50325-4

CAN bus was originally developed for use in automobiles, but has been used in mechanical engineering in a variety of applications.

CAN bus is primarily designed for transmission security and speed.

CAN bus has the following features:

- Multi master system: Each participant can transmit and receive.
- Topology: Linear structure with short stub line

- Network extension and band widths:
 - up to 25 m at 1 Mbit/s,
 - up to 5,000 m at 25 kbit/s
 - Addressing type: Message-oriented via identifier
Priority assignment of the message via identifier.
 - Safety: Hamming distance = 6, i.e. up to 6 individual errors/messages are recognized.
 - Bus physics: ISO 11989,
 - Max. number of participants: 127
-

PROFIBUS DP-V1

According to EN 61158

PROFIBUS has been developed for process and production industries and therefore is being supported by many manufacturers of control systems.

PROFIBUS has the following features:

- Multi master system: Several masters share access time and initiate communication. Slaves only react to requests
- Topology: Linear structure with short stub line

- Network extension and transmission rates
 - up to 100 m at 12 Mbit/s
 - up to 1200 m at 9.6 kbit/s per segment.
 - Repeaters may be used
 - Addressing type: Priority/cycle time assignment of messages by master configuration
 - Bus physics: RS-485 according to EIA-485
 - Max. number of participants: 126
-

ETHERCAT

According to IEC/PAS 62407

EtherCAT has been developed as the bus for industry due to increasing requirements with respect to cycle times based on Ethernet. EtherCAT bus is designed for high data transmission rates and fast cycle times.

The EtherCAT bus has the following features:

- Single master system: Master initiates communication
Slaves only react to requests

- Topology: Line, star, tree and ring structure following the daisy chain principle
- Network extension and band widths: 100 m between participants, 100 MBit/s
- Addressing type: Address oriented, one datagram for all participants
- Bus physics: Fast Ethernet 100 Base Tx
- Max. number of participants: 65535

GENERAL

The Windows®-based configuration software “Moog Valve Configurator” enables fast and convenient commissioning, diagnosis and configuration of the valve. Data may be uploaded from the PC to the valve; current settings may be downloaded from the valve to the PC. The valve can be control-

led via graphic control elements. Status information, set values and actual values as well as characteristic lines, are displayed graphically.

System parameters can be recorded and visualized via an integrated oscilloscope/data logger.

CONFIGURATION SOFTWARE

System requirements:

The configuration software can be configured on a PC with the following minimal requirements:

- IBM-PC compatible with 133 MHz
- Windows® 95/98/ME, Windows® NT/2000/XP
- 64 MB RAM
- 40 MB free hard disc capacity
- Monitor 640x480 Pixel resolution
- Keyboard, mouse

Recommended specification:

- IBM-PC compatible with 300 MHz
- Windows® NT/2000/XP

To use the software, the following options are additionally required: (see also accessories list, page 19)

- Free USB-Port
- USB commissioning module
- configuration / commissioning cable
- Valve connection cable (11+PE)
- Adapter M8 service socket (not required for Field Bus CANOpen)
- Power supply 24 V DC / > 0.5 A

Note:

Configuration / commissioning using the “Moog valve configuration software” is performed using the Field Bus socket (Field Bus CANOpen), otherwise (Field Bus Profibus DP, EtherCAT or analog control) using the integrated M8 service socket.

The software will be provided by Moog on request at no charge.

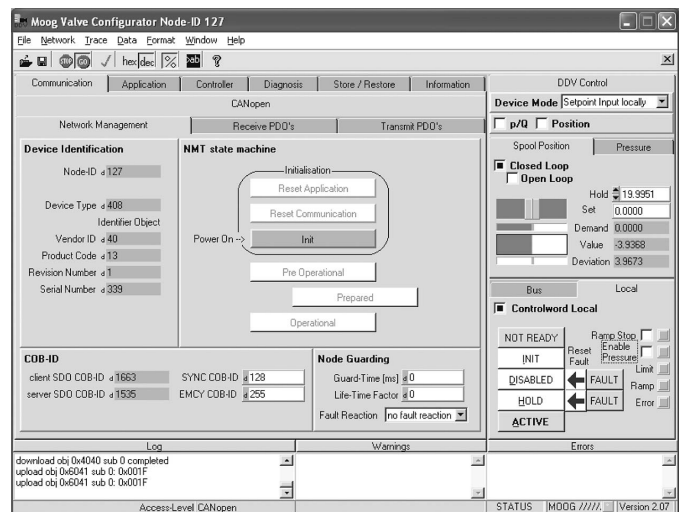

PERFORMANCE SPECIFICATIONS FOR STANDARD MODELS

Valve construction type	Spool version, two-stage
Mounting pattern	according to ISO 4401-05-05-0-05, additional with 2nd tank port
Ø of the ports	11,5 mm (0.45 in)
Valve configuration	2-way, 3-way, 4-way, 5-way and 2x2-way operation
Pilot stage	ServoJet®
Pilot oil supply	Optional external or internal (see page 5)
Rated flow Q_N	8 / 30 / 60 / 80 / 2x80 l/min (depending on model), [2.08 / 7.8 / 15.6 / 20.8 / 2x20.8 gals/min] ±10% at $\Delta p_N = 5$ bar per control edge
Max. flow	180 l/min (46.8 gals/min)
Max. leakage flow $Q_L^{1)}$	3.5 l/min total maximum [0.91 gals/min] 1.7 l/min (pilot stage only) [0.44 gals/min]
Step response time for 0 bis 100% stroke	33 ms (typical)
Hysteresis ^{1) 2)}	< 0.05 % (typical) max. 0.10 % (Q function)
Null shift	< 1.5 % at $\Delta T = 55$ K (Q function)
Linearity of pressure control	< 0,5 %

¹⁾ Control / operating pressure $p_x = 210$ bar (3000.9 psi), oil viscosity $\nu = 32$ mm²/s (1.26 in²/s) and an oil temperature of 40° C (104 °F).

²⁾ Hysteresis of p function dependent on controller optimization

OPERATING CONDITIONS

Max. operating pressure range	
Main stage	
Port P, A, B	[bar] 350 (depending on pressure transducer) (5001.5 psi)
Port T with Y internal	[bar] 210 (3000.9 psi)
Port T with Y external	[bar] 250 (3572.5 psi)
Pilot stage: Serial design	[bar] 280 (4002.2 psi)
With integrated pre reduction stage (on request)	[bar] 350 (5001.5 psi)
Permissible ambient temperature	
Ambient temperature	-20 °C to +60 °C (-4 °F to +140 °F)
Vibration protection	30 g, 3 axis, 10 Hz to 2 kHz
Shock protection	50 g, 6 directions
Sealing	NBR, FPM, other on request
Hydraulic fluid	
Permissible fluids	Hydraulic oil based on mineral oil according to DIN 51524, parts 1-3, others on request
Permissible temperature	-20 °C to +80 °C (-4 °F to +176 °F)
Viscosity ν	
Recommended	15 to 45 mm ² /s (0.6 to 1.77 in ² /s)
Permissible	5 to 400 mm ² /s (0.19 to 15.7 in ² /s)
Clean class, recommended for	
Functional safety	ISO 4406 < 19/16/13
Endurance (wear)	ISO 4406 < 17/14/11
Dust protection cover	Shipped with oil tight dust protection cover
Installation options	in all orientations, observe venting of pressure transducer
Protection class according to DIN EN60529	IP 65 (with mounted plugs)
Storage temperature	-20 °C to + 80 °C (-4 °F to +176 °F)

Typical characteristic curves for step response and frequency response at a pilot pressure $p_x = 210 \text{ bar}$ (3,000.9 psi), oil viscosity $\nu = 32 \text{ mm}^2/\text{s}$ (1.26 in^2/s) and oil temperature of $40 \text{ }^\circ\text{C}$ (104 $^\circ\text{F}$).

STEP RESPONSE

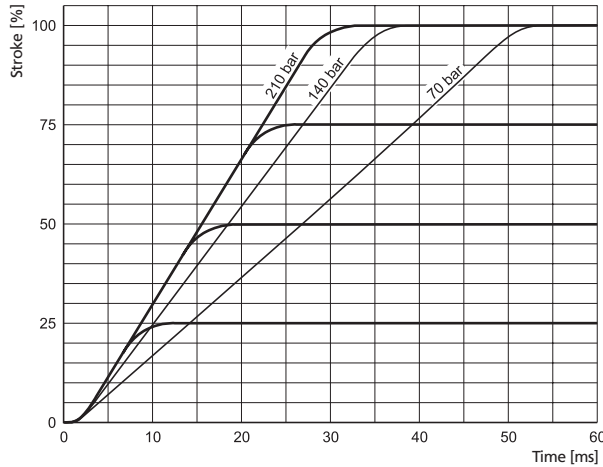

FREQUENCY RESPONSE

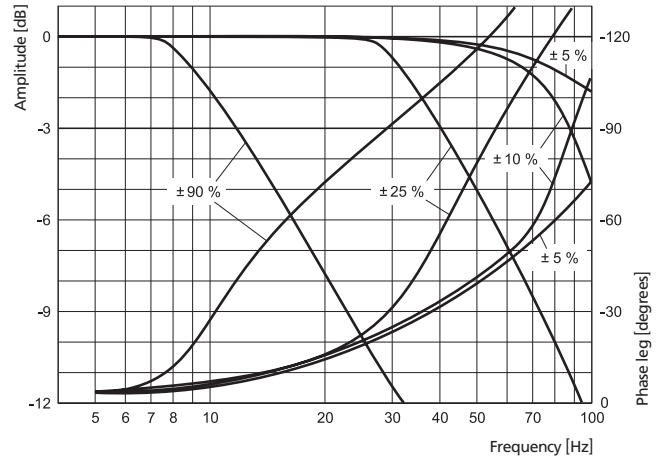

VOLUME FLOW SIGNAL CURVE

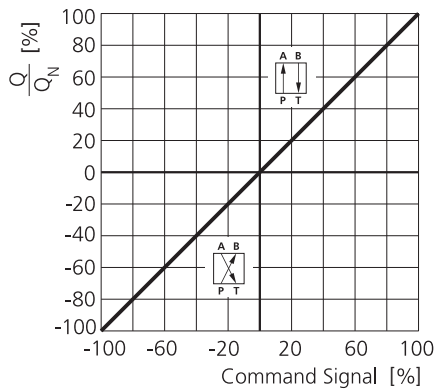

PRESSURE SIGNAL CURVE (PRESSURE CONTROLLED VALVE)

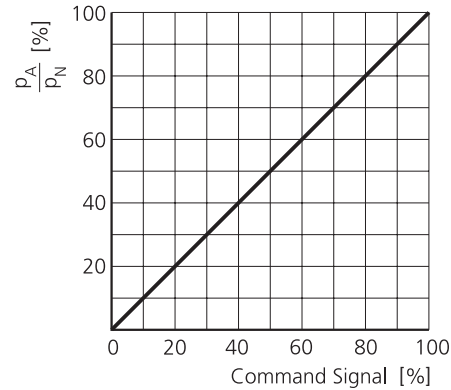

Note: The pressure control electronics must be adapted to the load for each new application. Moog will provide support on request.

INSTALLATION DRAWING

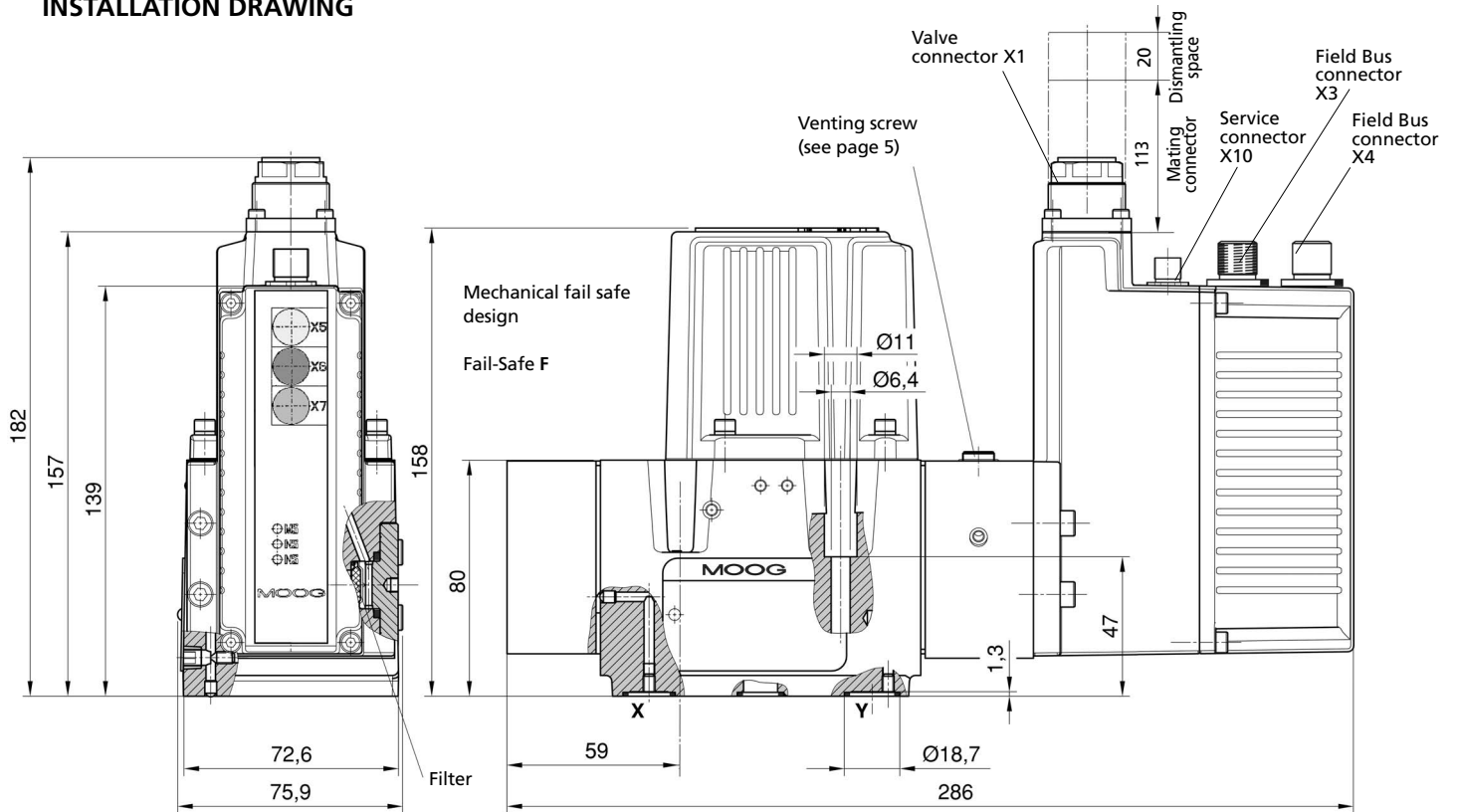

Mechanical fail safe design

Fail-Safe M/D

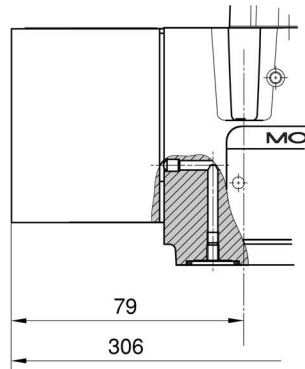

MOUNTING PATTERN OF THE MOUNTING FACE ACCORDING TO ISO 4401-05-05-0-05

Attention:

Observe mounting dist. min. 100 mm (3.93 in) due to O-ring dimensions X and Y.

For valves in 4-way design with $Q_N > 60$ l/min (15.6 gals/min) and 2x2 way design the second tank port T1 is required. For the 5-way design P- and T-ports are interchanged, that means T becomes P, T₁ becomes P1 and P becomes T.

X and Y have to be external.

For a maximum flow, the connector ports for P, T, T₁, A and B must be Ø11.5 mm (0.45 in), different to the standard. Flatness of mounting face <0.01 mm (0.0004 in) per 100 mm (3.9 in), average roughness Ra better than 0.8 µm.

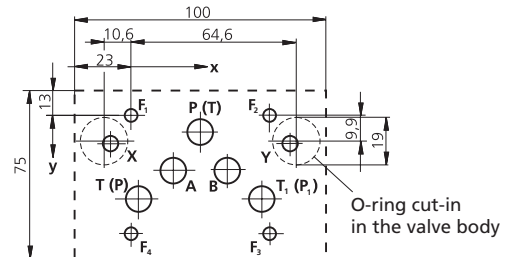

	P	A	B	T	T ₁	X	Y	F ₁	F ₂	F ₃	F ₄
	Ø11,5	Ø11,5	Ø11,5	Ø11,5	Ø11,5	Ø6,3	Ø6,3	M6	M6	M6	M6
x	27	16,7	37,3	3,2	50,8	-8	62	0	54	54	0
y	6,3	21,4	21,4	32,5	32,5	11	11	0	0	46	46

INSTALLATION DRAWING FOR VALVES WITH CAN-FIELD BUS CONNECTOR ^{1) 2)}

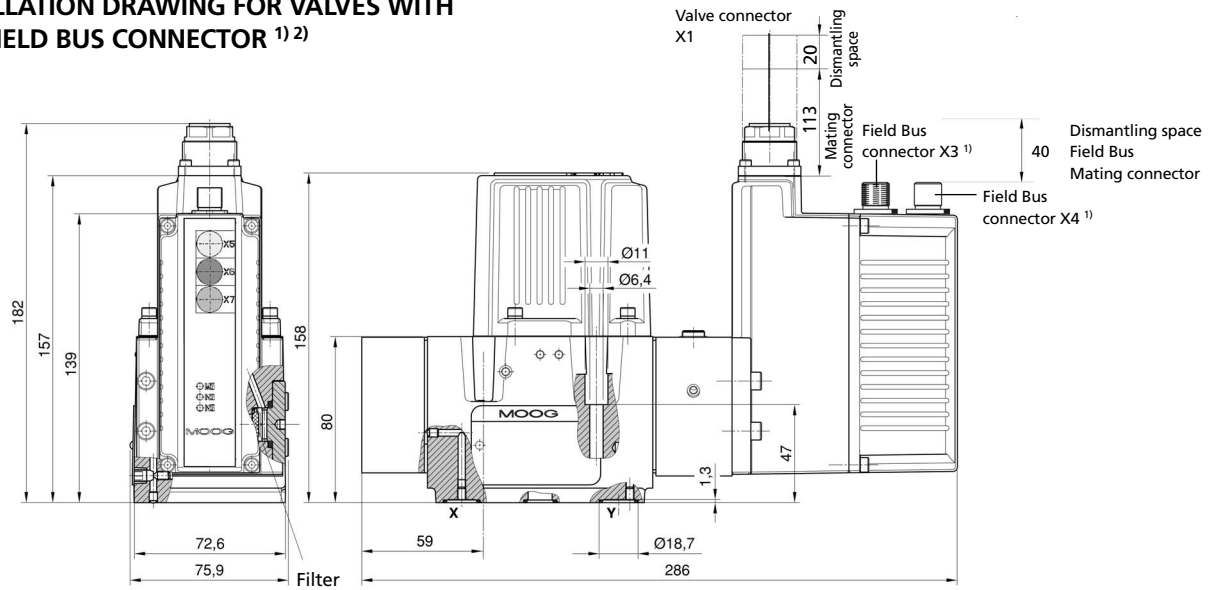

INSTALLATION DRAWING FOR VALVES WITH PROFIBUS-DP OR ETHERCAT-FIELD BUS-SOCKET ²⁾

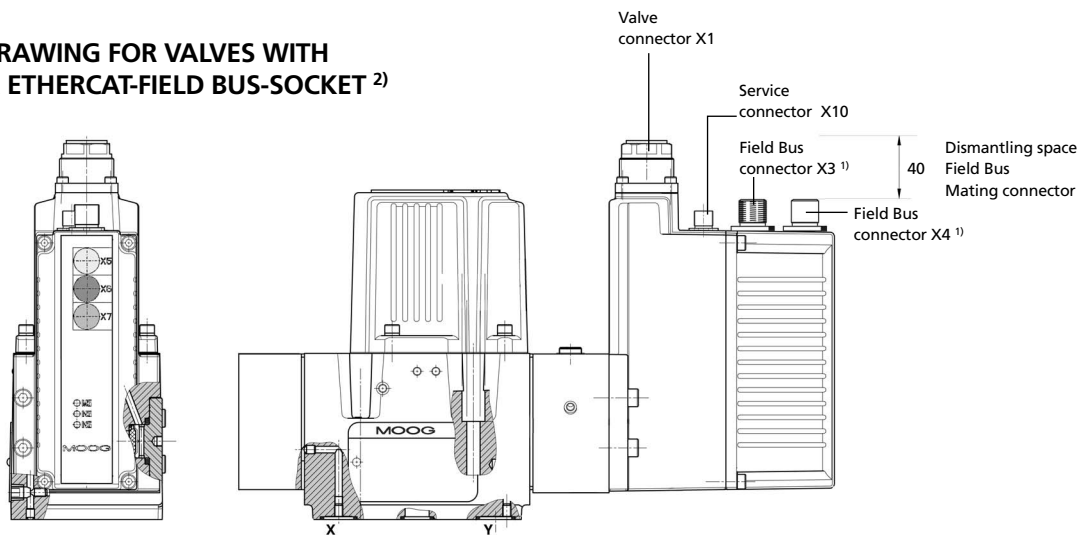

INSTALLATION DRAWING FOR VALVES WITH ANALOG CONTROL ²⁾

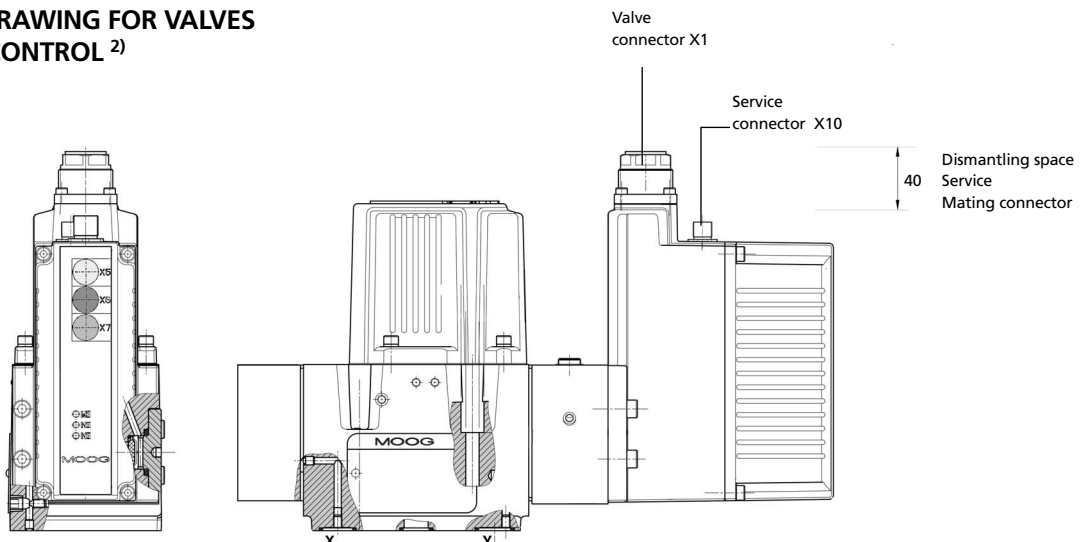

¹⁾ Standard details see page 9

²⁾ Length dimensions for the mechanical fail-safe design Failsafe F

VALVES FOR APPLICATIONS WITH SAFETY REQUIREMENTS (FAIL-SAFE)

For applications with pQ-proportional valves where certain safety regulations are applicable, a safe metering spool position is needed in order to avoid potential damage. Therefore, a fail-safe version is offered as an option for the multi-stage proportional valves. After switching off the 24 V supply to the safety solenoid valve, this fail-safe function gives a safe metering spool position: overlapped centered position or fully opened A → T or B → T.

In order to move the spool to the safe central position with D941 Series fail-safe valves, the two control chambers of the main stage are hydraulically short circuited via a 2/2-way solenoid valve. The spring force moves the spool into the fail-safe position.

With fail-safe valves, it is possible to check whether the main spool is in a safe position. If the main spool is within the defined safe range, the logic output signal at pin 11 is > + 8.5 V. If this signal is < + 6.5 V, then the main spool is outside the safe range.

This logic signal may be delayed up to 500 ms. To reduce the fail-safe switching time, it is advisable to switch off the supply of the 2/2 way valve and the enable signal at the same time.

NOTE:

According to DIN-EN 954-1, a higher safety category can be achieved if a fail-safe valve is used.

In this connection attention should be paid to appropriate machine safety standards.

ELECTRIC CHARACTERISTICS

2/2-way solenoid valve for the fail-safe version. For more information on fail-safe versions, see Moog Application Note Signal reference value wiring AM 423.

Valve construction type	2/2 way valve
Function	electro magnetic
Nominal voltage U_N	24 V DC
	(min. 22.8 V DC, max. 26.4 V DC)
Nominal power P_N	26 W

Connector wiring

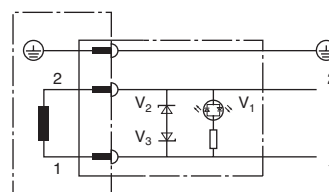

DIN EN 175301 Part 803
with free wheel and light diode

WIRING FOR VALVES WITH 11+PE-POLE CONNECTOR WITH INTEGRATED FAIL-SAFE SUPPLY

To EN 175201 part 804, mating connector (metal) with leading protective ground connection (⊕).

Pin	Signal	Voltage floating ±10 V, 0 to 10 V	Current floating ±10 mA, 0 to 10 mA, 4 to 20 mA ¹⁾
1	Supply, 2/2 way valve	24 V DC (min. 22,8 V DC, max 26,4 V DC, max 1,20 A)	
2	Supply, 2/2 way valve	⊥ (0 V)	
3	Enable input	8.5 to 32 V DC above GND: operation of the valve enabled <6.5 V DC above GND: Valve fail-safe condition	
4	Command value input Q-function	$U_{in} = U_{4-5}$ $R_{in} = 20\text{ k}\Omega$	$I_{in} = I_4 = -I_5$ (for $I_7=0$) ²⁾ $R_{in} = 200\ \Omega$
5	Reference point Command inputs	Reference to ground for pin 4 and 7	common feedback for pin 4 and 7
6	Output Actual valve spool position	$I_{out} = 4$ to 20 mA referenced to GND (I_{out} proportional to the position of the spool; the output is short circuit protected; for conversion of actual value output signal I_{out} see page 7); $R_L = 0$ to 500 Ω	
7	Command value input p-function	$U_{in} = U_{7-5}$ $R_{in} = 20\text{ k}\Omega$	$I_{in} = I_7 = -I_5$ (for $I_4=0$) ²⁾ $R_{in} = 200\ \Omega$
8	Output Actual pressure	$I_{out} = 4$ to 20 mA referenced to GND (I_{out} is proportional to pressure in port A; the output is short circuit protected; for conversion of actual value signal I_{out} see page 7); $R_L = 0$ to 500 Ω	
9	Supply voltage	24 V DC (18 to 32 V DC) above GND	
10	Power ground	GND	
11	digital output	Error monitoring ³⁾	
⊕	Protective conductor contact		

The potential difference between pins 4, 5 and 7 (measured against pin 10) must be between -15 and +32 V.

- 1) Command value signals $I_{in} < 3$ mA (due to, e.g. wire break) mean an error condition for signals 4 to 20 mA.
The valve reaction to this defect may be customized and activated by the customer.
- 2) As pin 5 is the common feedback for pin 4 and pin 7, $-I_5 = I_4 + I_7$ applies.
- 3) Output may be factory programmed, "low" means error (e.g. spool is no longer in a safe position. description see page 16).

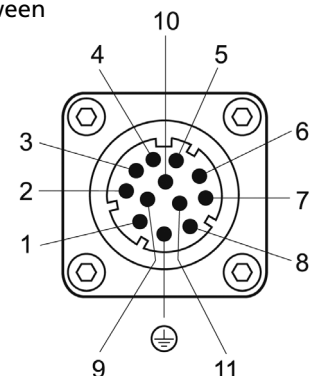

SPARE PARTS AND ACCESSORIES

Part designation	Quantity	Comments	Part number
Sealing service kit (contains all O-rings for ports to mounting face and for filter exchange)	1	NBR 85 Shore FPM 85 Shore (Not included in delivery)	B97215-N661F10 B97215-V661F10
- O-rings for ports P, T, T ₁ , A, B	5	ID 12.4 x Ø 1.8: (0.48 in x 0.07 in)	NBR 85 Shore FPM 85 Shore -45122-004 -42082-004
- O-ring for ports X, Y	2	ID 15.6 x Ø 1.8: (0.61 in x 0.07 in)	NBR 85 Shore FPM 85 Shore -45122-011 -42082-011
- O-rings for filter exchange for filter	1	ID 12 x Ø 2.0: (0.47 in x 0.07 in)	NBR 85 Shore FPM 85 Shore -66117-012-020 A25163-012-020
for filter cap	1	ID 17.1 x Ø 2.6: (0.67 in x 0.1 in)	HNBR85 Shore FPM 85 Shore B97009-080 -42082-050
Exchangeable filter element	1		A67999-200
Mounting screws for proportional valve	4	M 6 x 60 DIN EN ISO 4762, grade 10.9, Tightening torque 11 Nm (not included in delivery)	A03665-060-060
Flushing plate for P, A, B, T, T₁, X, Y	1	(Not included in delivery)	B67728-001
Flushing plate for P, T, T₁, X, Y	1		B67728-002
Flushing plate for P, T, T₁ and X, Y	1		B67728-003
Connecting plates		On request	
Dust protection cover	1		A40508
Dust protection cover for Field Bus mounting socket		Required for operation without mating connector (IP protection) (not included in delivery)	
- with external thread	1		C55823-001
- with internal thread	1		CA24141-001
Mating connector for 11+PE pole mounted connector, IP65 (metal)	1	EN 175201-804 with min. Ø 11 mm (0.43 in), max. Ø 13 mm (0.51 in) (Not included in delivery)	B97067-111
11+PE-cable (3 m)	1	(Not included in delivery)	C21031-003-001
Configuration/commissioning cable	1	On request	
USB commissioning module	1	(Not included in delivery)	C43094-001
Configuration/commissioning cable	1	(Not included in delivery)	TD3999-137
Adapter M8 service socket	1	Additionally, configuration/commissioning cable TD3999-137 is required (Not included in delivery)	CA40934-001
Power supply 10A	1	(Not included in delivery)	D137-003-001
Power cable (2m)	1	(Not included in delivery)	B95924-002
Operating instructions D941 Series	1	(Not included in delivery)	C43357-002

ORDERING INFORMATION

Model number (assigned at the factory)

Type signation

D941 -

1	2	3	4	5
.

Specification status

-	Series specification
Z	Special specification

Model designation

Factory identification

Variant

1 Valve version

Q	Standard spool
---	----------------

2 Rated flow

	Q _N (l/min) [gals/min] for Δp _N = 5 bar (71.45 psi) per spool land	
08	8	[2.08]
30	30	[7.8]
60	60	[15.6]
80	80	[20.8]

3 Pressure range in bar [psi]

	Max. operating pressure	
W	25	[357.25]
V	100	[1429.0]
U	160	[2286.4]
T	250	[3575.2]
K	350	[5001.5]
	Calibrated pressure may differ from max. operating pressure	

4 Pilot bushing/spool design

B	3-way: P → A, A → T; ~zero lap, linear curve
U	5-way: P ₁ → A, P ₂ → B; A → T; ~zero lap, broken curve
T	4-way: linear curve P → A and P → B: 20 % positive lap A → T and B → T: 15 % negative lap
Z	2x2-way: A → T, B → T ₁ ; linear curve, closed for a 90% signal (only for bypass)
X	Special spool on request

5 Pilot stage design

	Design	Control volume flow (l/min) [gals/min] for p _x = 140 bar (2000.6 psi)
A	ServoJet®	1,30 [0.34]

Options may increase price.
All combinations may not be available.
Preferred configurations are highlighted.

ORDERING INFORMATION

6	7	8	9	10	11	12	13	14	15	16																																										
•	•	•	•	•	•	•	•	•	•	•																																										
<p>16 Valve functionality</p> <p>B1 p-functionality C1 p/Q-functionality</p>																																																				
<p>15 Service connector X10</p> <p>O1 without ⁴⁾ K1 with ⁵⁾</p>																																																				
<p>14 Field bus connector X3, X4</p> <p>C CAN D Profibus DP³⁾ E EtherCAT³⁾ O without³⁾</p>																																																				
<p>13 Release function</p> <p>A Without release signal, the spool moves to a selected controlled zero position. B Without release signal, the control spool moves to a defined final position L Without release signal, the control spool moves to a defined final position A → T or B → T with spool position monitoring</p>																																																				
<p>12 Valve design</p> <p>N Flow modulation with max. pressure limitation¹⁾ K Flow modulation with min. pressure limitation¹⁾ C Bypass valve, Flow modulation with max. pressure limitation¹⁾ M Pressure control in the main line²⁾</p>																																																				
<p>11 Supply voltage</p> <p>2 24 V DC (18 to 32 V DC)</p>																																																				
<p>10 Signals for flow Q and pressure p</p> <table border="1"> <thead> <tr> <th></th> <th>Input signal Q</th> <th>Input signal p</th> </tr> </thead> <tbody> <tr> <td>M</td> <td>± 10 V</td> <td>0 to +10 V</td> </tr> <tr> <td>X</td> <td>± 10 mA</td> <td>0 to +10 mA</td> </tr> <tr> <td>E</td> <td>4 to 20 mA</td> <td>4 to 20 mA</td> </tr> <tr> <td>9</td> <td colspan="2">Field Bus digital ⁶⁾</td> </tr> </tbody> </table> <p>Actual value output Spool position / pressure 4 to 20 mA</p>												Input signal Q	Input signal p	M	± 10 V	0 to +10 V	X	± 10 mA	0 to +10 mA	E	4 to 20 mA	4 to 20 mA	9	Field Bus digital ⁶⁾																												
	Input signal Q	Input signal p																																																		
M	± 10 V	0 to +10 V																																																		
X	± 10 mA	0 to +10 mA																																																		
E	4 to 20 mA	4 to 20 mA																																																		
9	Field Bus digital ⁶⁾																																																			
<p>9 Valve connector X1</p> <p>E 11+PE-pole EN 175201 part 804</p>																																																				
<p>8 Seal material</p> <p>H NBR V FPM others on request</p>																																																				
<p>7 Control type and control pressure</p> <table border="1"> <thead> <tr> <th></th> <th>Inlet X</th> <th>Outlet Y</th> </tr> </thead> <tbody> <tr> <td>4</td> <td>internal</td> <td>internal</td> </tr> <tr> <td>5</td> <td>external</td> <td>internal</td> </tr> <tr> <td>6</td> <td>external</td> <td>external</td> </tr> <tr> <td>7</td> <td>internal</td> <td>external</td> </tr> </tbody> </table>												Inlet X	Outlet Y	4	internal	internal	5	external	internal	6	external	external	7	internal	external																											
	Inlet X	Outlet Y																																																		
4	internal	internal																																																		
5	external	internal																																																		
6	external	external																																																		
7	internal	external																																																		
<p>6 Spool position without electric supply</p> <p>Mechanical Fail-Safe design</p> <table border="1"> <thead> <tr> <th></th> <th>Position</th> <th>p_p (bar) [psi]</th> <th>p_x extern (bar) [psi]</th> </tr> </thead> <tbody> <tr> <td>F</td> <td>defined final pos. A → T</td> <td></td> <td>independent</td> </tr> <tr> <td>D</td> <td>defined final pos. P → A</td> <td></td> <td>independent</td> </tr> <tr> <td rowspan="2">M</td> <td>defined central pos.</td> <td>≥ 25 [357.25]</td> <td>< 1 [14.29]</td> </tr> <tr> <td>undefined</td> <td>≥ 25 [357.25]</td> <td>≥ 25 [357.25]</td> </tr> </tbody> </table> <p>Electrically operated Fail-Safe design</p> <table border="1"> <thead> <tr> <th></th> <th>Position</th> <th>p_p (bar) [psi]</th> <th>p_x</th> <th>WV*</th> <th>VEL**</th> </tr> </thead> <tbody> <tr> <td rowspan="2">W</td> <td>defined central pos.</td> <td>≥ 25 [357.25]</td> <td>≥ 25 [357.25]</td> <td>off</td> <td>on/off</td> </tr> <tr> <td>defined central pos.</td> <td>≥ 25 [357.25]</td> <td>< 1 [14.29]</td> <td>on/off</td> <td>on/off</td> </tr> <tr> <td>X</td> <td colspan="5">others on request</td> </tr> </tbody> </table>												Position	p _p (bar) [psi]	p _x extern (bar) [psi]	F	defined final pos. A → T		independent	D	defined final pos. P → A		independent	M	defined central pos.	≥ 25 [357.25]	< 1 [14.29]	undefined	≥ 25 [357.25]	≥ 25 [357.25]		Position	p _p (bar) [psi]	p _x	WV*	VEL**	W	defined central pos.	≥ 25 [357.25]	≥ 25 [357.25]	off	on/off	defined central pos.	≥ 25 [357.25]	< 1 [14.29]	on/off	on/off	X	others on request				
	Position	p _p (bar) [psi]	p _x extern (bar) [psi]																																																	
F	defined final pos. A → T		independent																																																	
D	defined final pos. P → A		independent																																																	
M	defined central pos.	≥ 25 [357.25]	< 1 [14.29]																																																	
	undefined	≥ 25 [357.25]	≥ 25 [357.25]																																																	
	Position	p _p (bar) [psi]	p _x	WV*	VEL**																																															
W	defined central pos.	≥ 25 [357.25]	≥ 25 [357.25]	off	on/off																																															
	defined central pos.	≥ 25 [357.25]	< 1 [14.29]	on/off	on/off																																															
X	others on request																																																			

1) Only in combination with "C1" valve functionality

2) Only in combination with "B1" valve functionality

3) Valve parameterization with commissioning software "MOOG VALVE CONFIGURATOR" using M8 service plug

4) Only in combination with Field Bus connector "C"

5) Only in combination with Field Bus connector "D, E, O"

6) Only in combination with Field Bus connector "C, D, E" (may be switched to analogue signals "M, X, E")

WV* = 2/2-way seat valve / VEL** = valve electronics

As a recognized leader in motion control technologies, Moog offers a full range of services to support our products and ensure that they meet the expectations of customers. Moog experts are the best at helping customers select the right products and ensuring that they run reliably for a long time.

When it is time for new machine commissioning, refurbishment or routine maintenance, our engineers can help to optimize machine performance, minimize downtime and ensure the smooth application of our products.

Known for the ability to customize products for the unique needs of our customers, we are uniquely able to handle customer needs and supply services throughout the life cycle of the product. **Moog Authentic Repair®** is designed to provide the highest quality repair services using original equipment parts, the latest design specifications, and highly trained technicians. This ensures that our repaired products will run as well as when they were new.

With facilities in over 25 countries, Moog is committed to offering convenient local service to our customers.

Visit www.moog.com/industrial/globallocator to find the location nearest you for application engineering, repair, or field services.

FOR MORE INFORMATION VISIT
<http://www.moog.com/industrial>

MOOG.COM/INDUSTRIAL

For the Moog location nearest you, contact moog.com/industrial/globallocator.

Argentina	+54	(0) 11 4326 5916	info.argentina@moog.com
Australia	+61	(0) 3 9561 6044	info.australia@moog.com
Austria	+43	(0) 1 688 1384	info.austria@moog.com
Brazil	+55	(0) 11 5523 8011	info.brazil@moog.com
China	+86	(0) 21 5854 1411	info.china@moog.com
Finland	+358	(0) 9 2517 2730	info.finland@moog.com
France	+33	(0) 1 4560 7000	info.france@moog.com
Germany	+49	(0) 7031 622 0	info.germany@moog.com
Hong Kong	+852	2 635 3200	info.hongkong@moog.com
India	+91	(0) 80 4120 8799	info.india@moog.com
Ireland	+353	(0)21 451 9000	info.ireland@moog.com
Italy	+39	0332 42111	info.italy@moog.com
Japan	+81	(0)463 55 3615	info.japan@moog.com
Korea	+82	(0) 31 764 6711	info.korea@moog.com
Luxembourg	+352	40 46 401	info.luxembourg@moog.com
Netherlands	+31	(0) 252 462 000	info.netherlands@moog.com
Norway	+47	224 32927	info.norway@moog.com
Russia	+7	(8) 31 713 1811	info.russia@moog.com
Singapore	+65	677 36238	info.singapore@moog.com
South Africa	+27	(0) 11 655 7030	info.southafrica@moog.com
Spain	+34	902 133 240	info.spain@moog.com
Sweden	+46	(0) 31 680 060	info.sweden@moog.com
Switzerland	+41	(0) 71 394 5010	info.switzerland@moog.com
United Kingdom	+44	(0) 168 429 6600	info.unitedkingdom@moog.com
USA	+1	716 652 2000	info.usa@moog.com

©2006 Moog Inc.

Moog is a registered trademark of Moog, Inc. and its subsidiaries. All quoted trademarks are the property of Moog, Inc. and its subsidiaries. All rights reserved.

Specifications may be revised without notice. Comparisons based on internal Moog data.

D941_en_11/2006