

MOOG

DS2000XP High Performance Servodrives



Customizable Integrated Axis Motion
Control for Brushless Servomotors and
Actuators in Closed-Loop Applications

Section	Page
Overview	2
Features and Benefits	3
Technical Data	4-10
Ordering Information	11

HALF A CENTURY OF EXCELLENCE IN MOTION CONTROL

Moog has provided superior motion control solutions for the industrial marketplace for over 50 years. A leading designer and manufacturer of electric control products for over 20 years, Moog Electro-Mechanical Actuators, Servomotors, and Servodrives are known for reliability and accurate control. The Servodrive product line is a proven option for customers that need high dynamic performance and control accuracy. Moog Servodrives are user-friendly for easy installation and maintenance, and reliable for use in heavy-duty applications.

THE DS2000XP SERVODRIVE CONTROL SOLUTION

The DS2000XP Servodrive is a self-contained, fully digital stand-alone motion control drive with a highly customizable interface for control of brushless motors and actuators in high performance closed-loop applications. This servodrive has a high-performance 32-bit floating-point Motorola MPC555 RISC CPU on board to provide strong embedded real-time motion control capability.

The DS2000XP is ideal for applications requiring integrated axis motion control including simulation, power generation and all MaxForce actuator applications. This servodrive accepts a wide range of power supply. The DS2000XP can also operate a broad range of brushless servomotors and Electro-Mechanical Actuators with resolver or Sin/Cos encoder feedback devices.

This catalog is for users with technical knowledge. To ensure that all necessary characteristics for function and safety of the system are given, the user has to check the suitability of the products described herein. The products described herein are subject to change without notice. In case of doubt, please contact Moog.

Moog is a registered trademark of Moog Inc. and its subsidiaries. Unless expressly indicated, all trademarks as indicated herein are the property of Moog Inc. and its subsidiaries. For legal notices, see www.moog.com/literature/disclaimers.

©Moog Inc. 2005. All rights reserved.
All changes are reserved.
For the most current information, visit www.moog.com/servomotorsandservodrives

THE MOOG DS2000XP SERVODRIVE DESIGN

The DS2000XP has flexible motion control capabilities, very high performance, high resolution, absolute position feedback and built-in motion template for ease of use. It is highly customizable. This high performance servodrive is ideal on applications that require high bandwidth and very smooth motion. The DS2000XP features axis motion control, flexible control architecture, easy to use motion template for Electro-Mechanical Actuators and very high performance CAN-bus, FireWire and SERCOS interfaces.

- **ADVANCED CONTROL DESIGN**

The DS2000XP Servodrive has a state-of-the-art control design. The typical three-loops basic control algorithm provides excellent torque, speed and position loop closure. In addition, Application Engineers can use the widely recognized industrial simulation and control software Simulink™/Stateflow™ (Mathworks Co.) to generate sophisticated application control model and motion sequences. These sequences are then developed, tested and debugged offline on a PC. The working model is then automatically converted to a real-time code and downloaded to the DS2000XP Servodrive. This allows for added convenience, more uptime and rapid prototyping of advanced control algorithms.

- **FLEXIBLE CONTROL MODEL TEMPLATE**

Moog has developed model-based control templates to meet specific customer and market needs. Application parameters such as stroke length, homing method, motion limits and motion profile are used to customize a template to a specific application requirement. Some of the available template features are:

- Closed-loop position and velocity control loops up to 5KHz sampling rate
- Real-time trajectory control of position, velocity and acceleration limits
- Home sequencing with stroke limit verification
- Emergency stop sequencing
- IT current motor torque limiting
- Position following error detection
- Digital I/O handling
- Common units for application definition (ex: inches, mm, rpm, volts)
- Application input error checking (range, polarity)
- Special control functions

- **GRAPHICAL USER INTERFACE (GUI)**

A Windows-based GUI is available to help customer access the DS2000XP Servodrive over the RS232 port. GUI functions include:

- Control model downloading
- System configuration parameters downloading and uploading
- Application parameters downloading and uploading
- System tuning and diagnostics
- Servodrive status and fault status monitoring
- Graphical display of data logged variables

- **DIAGNOSTICS AND TUNING**

The local LCD display on the servodrive provides basic servodrive status and possible fault occurrence. It has the following functions:

- Motor automatic phasing
- Error detecting
- Basic parameter access and monitoring

- **FIELDBUS**

High-speed serial bus interfaces provide a fully digital link for receiving motion commands, providing feedback of status and initializing controller parameters.

- **MOTOR FEEDBACK**

In addition to the standard motor resolver feedback, the DS2000XP Servodrive interfaces to high resolution Sin/Cos encoders. Position resolution is greatly increased with a corresponding increase in velocity dynamic range. This translates to improved low speed performance.

PERFORMANCE SPECIFICATIONS

ELECTRICAL CHARACTERISTICS Power Supply Auxiliary Power Supply PWM Frequency Continuous Peak Output Current	3-phase, 65 Vac to 510 Vac; 1-phase, 103 Vac to 243 Vac 24 Vdc 10 kHz 3A/9A to 100A/240A (see chart below)
ENVIRONMENTAL DATA Operating Ambient Temperature Storage Temperature Thermal Protection	0 to 40°C -25 to +55°C 70°C to de-rating the drive
I/O INTERFACES	2 analog input, 0-20 mA or 10 V, 14 bit DAC 2 analog output, 0-20 mA or 10 V, 14 bit DAC 2 basic monitoring output (1 velocity, 1 programmable) 5 digital input, isolated 24 Vdc 3 digital output, isolated 24 Vdc 1 relay output (COM, NO, NC) 1 simulation encoder output
FIELDBUS	CANopen; SERCOS; FireWire; RS485 - Modbus
MOTOR FEEDBACK	Stegmann Hiperface incremental and multi-revolution absolute encoders; EnDat format Sin/Cos encoders; Resolution up to 2 ²⁴ encoder counts per revolution
MOTOR POLE RANGE	2 to 24 poles
SINUSOIDAL ENCODER RANGE	up to 24-bit resolution

Model		Output Currents			Weight lb (kg)	Size
Code	Type	Nominal (Arms)	Max (Arms)	Peak (A)		
G369-X 003	3/9	3	6.4	9	10 (4.5)	A
G369-X 004	4/12	4	8.5	12	10 (4.5)	A
G369-X 006	6/15	6	10.6	15	10 (4.5)	A
G369-X 008	8/22	8	16	22	10 (4.5)	A
G369-X 014	14/42	14	29.7	42	13 (6)	B
G369-X 020	20/45	20	31.8	45	22 (10)	C
G369-X 025	25/70	25	49.5	70	22 (10)	C
G369-X 030	30/90	30	63.6	90	22 (10)	C
G369-X 050	50/140	50	99.3	140	48.5 (22)	D
G369-X 060	60/180	60	127.6	180	48.5 (22)	D
G369-X 100	100/240	100	200	240	66 (30)	E

Note: Please refer to ordering code on page 11 for complete order numbers.

FUNCTION BLOCK DIAGRAM FOR TEMPLATE CONTROL SYSTEM

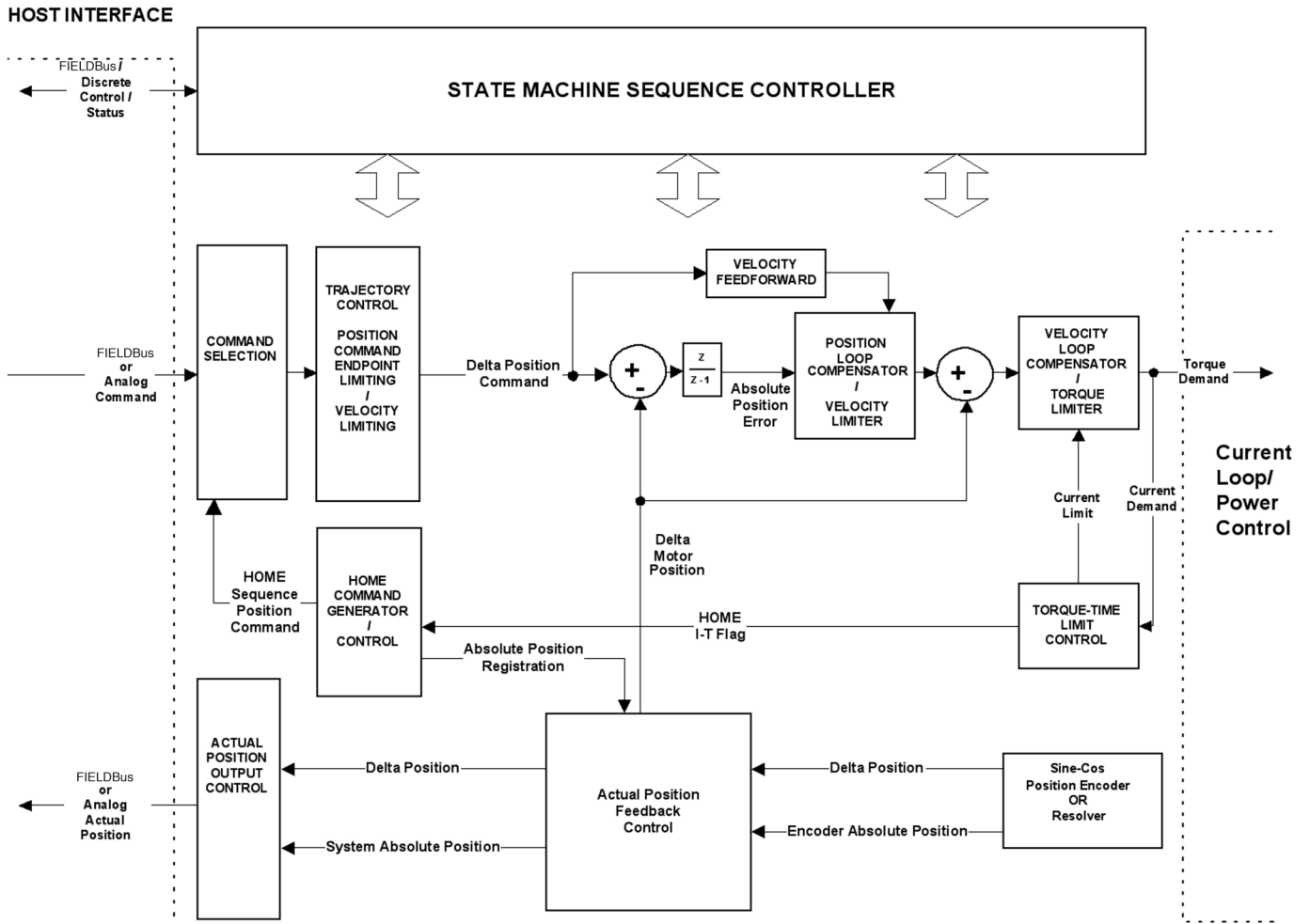

DS2000XP Size A - CONNECTORS AND DESCRIPTION

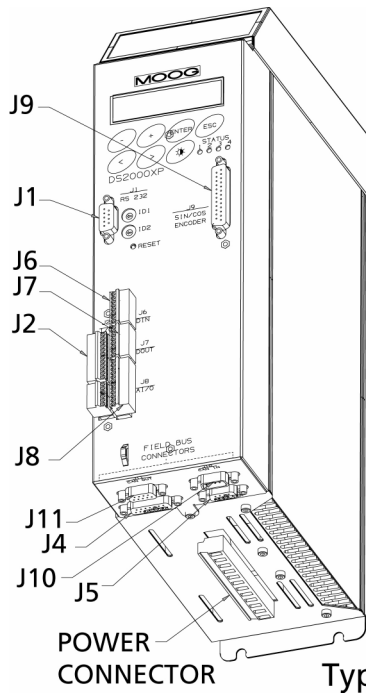

Type: 8/22

- J1 RS232 Communication
- J2 Servodrive Enable and monitoring
- J4 Motor Encoder feedback
- J5 Motor Resolver feedback
- J6 Digital Input
- J7 Digital Output
- J9 Sin/Cos Encoder feedback (optional)
- J10 CAN in (or SERCOS/FireWire)
- J11 CAN out (or SERCOS/FireWire)
- POWER AC or DC power supply and motor connection

DIMENSIONS

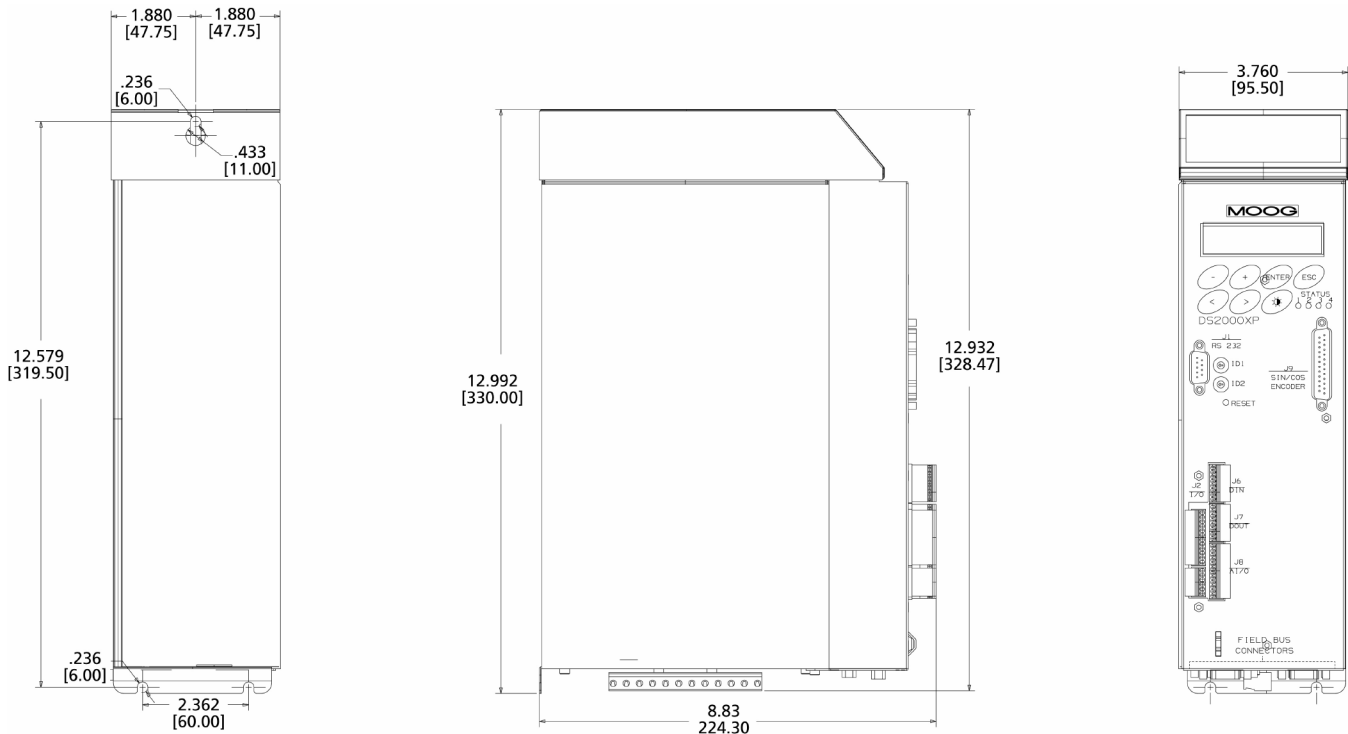

DS2000XP Size B - CONNECTORS AND DESCRIPTION

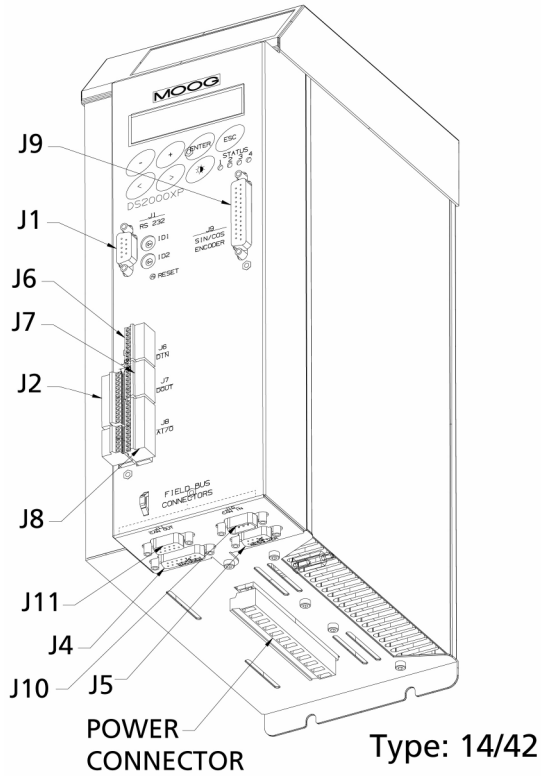

- J1 RS232 Communication
- J2 Servodrive Enable and monitoring
- J4 Motor Encoder feedback
- J5 Motor Resolver feedback
- J6 Digital Input
- J7 Digital Output
- J9 Sin/Cos Encoder feedback (optional)
- J10 CAN in (or SERCOS/FireWire)
- J11 CAN out (or SERCOS/FireWire)
- POWER AC or DC power supply and motor connection

DIMENSIONS

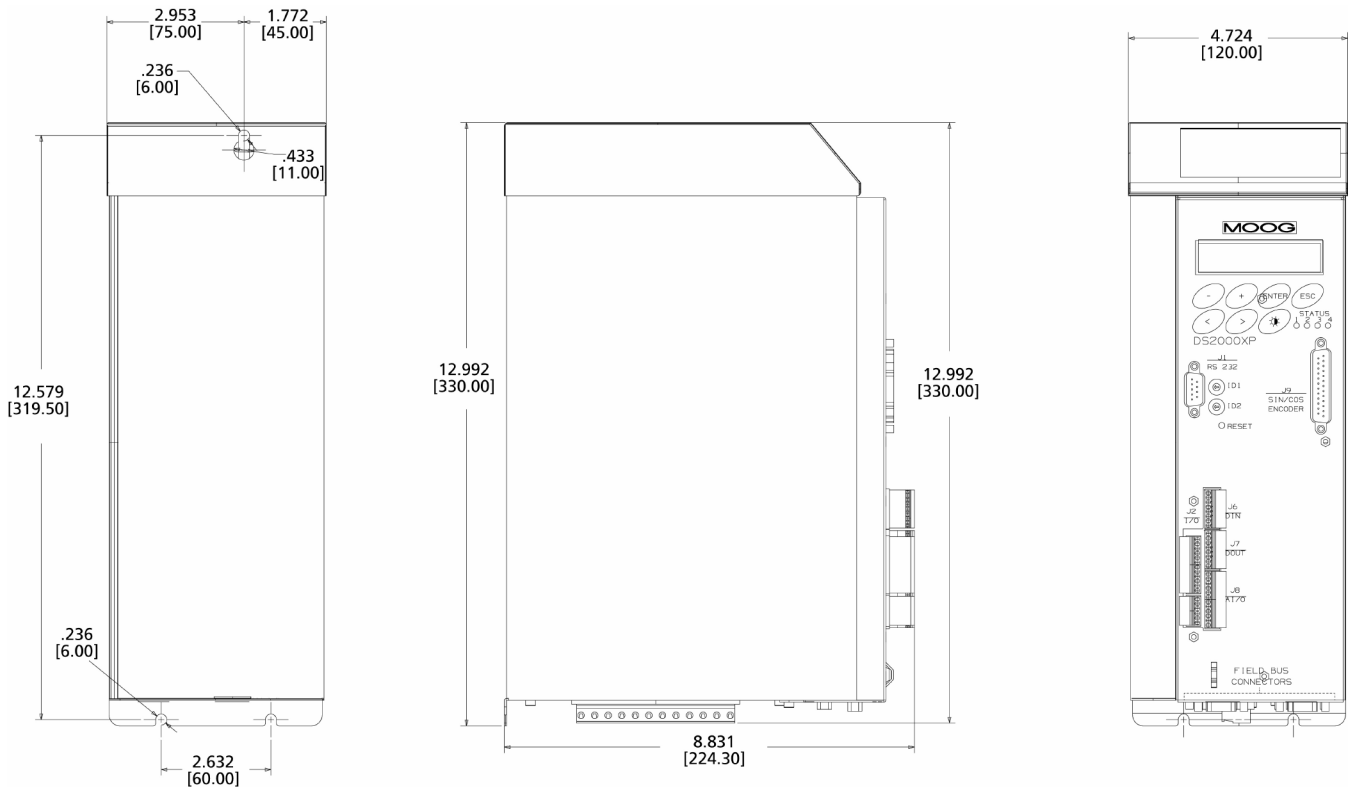

DS2000XP Size C - CONNECTORS AND DESCRIPTION

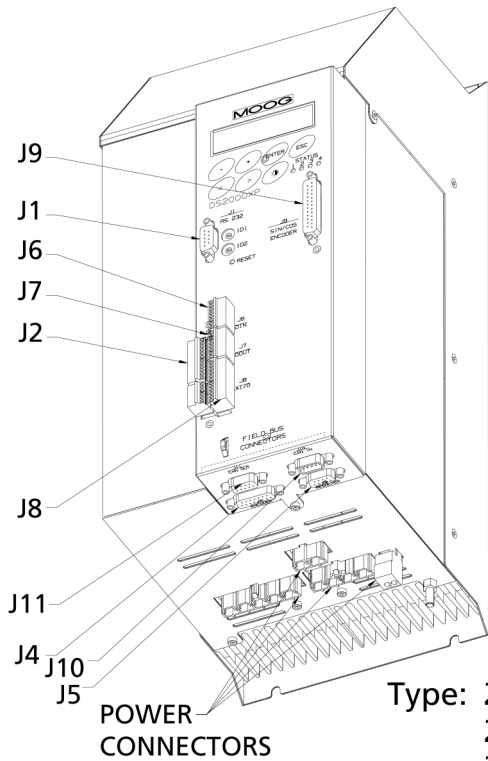

Type: 20/45
25/70
30/90

- J1 RS232 Communication
- J2 Servodrive Enable and monitoring
- J4 Motor Encoder feedback
- J5 Motor Resolver feedback
- J6 Digital Input
- J7 Digital Output
- J9 Sin/Cos Encoder feedback (optional)
- J10 CAN in (or SERCOS/FireWire)
- J11 CAN out (or SERCOS/FireWire)
- POWER AC or DC power supply and motor connection

DIMENSIONS

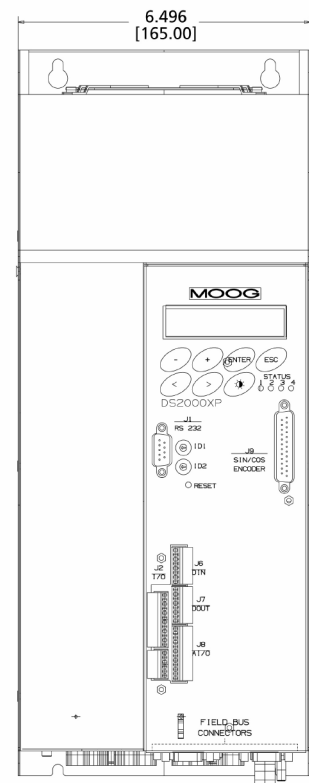
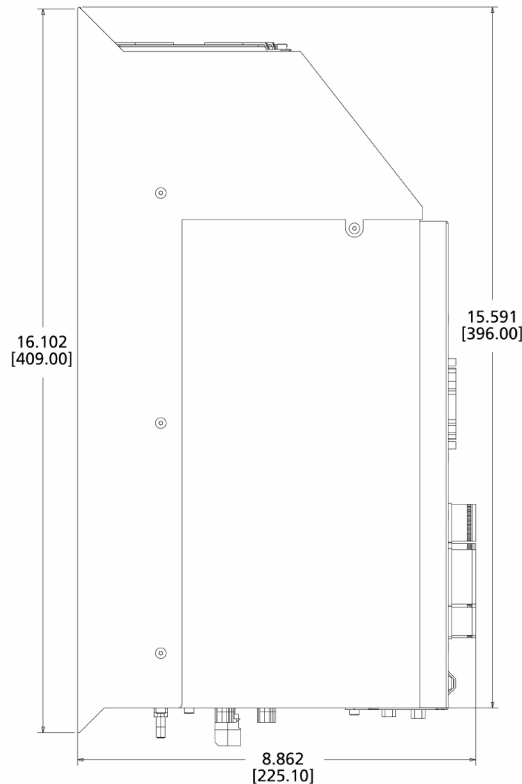
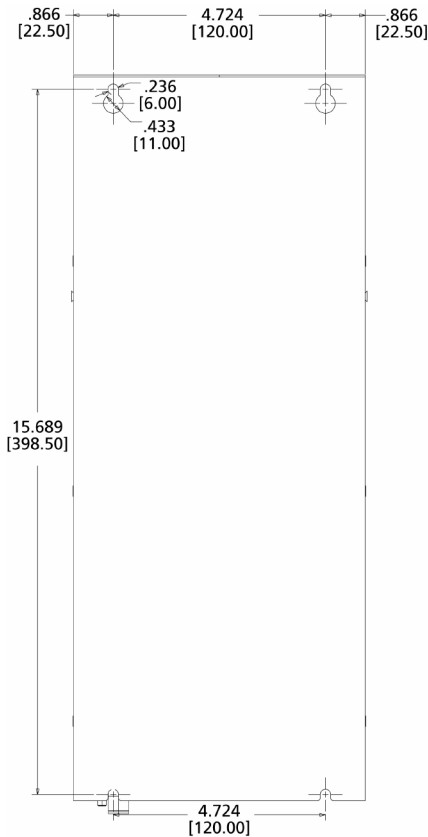

DS2000XP Size D - CONNECTORS AND DESCRIPTION

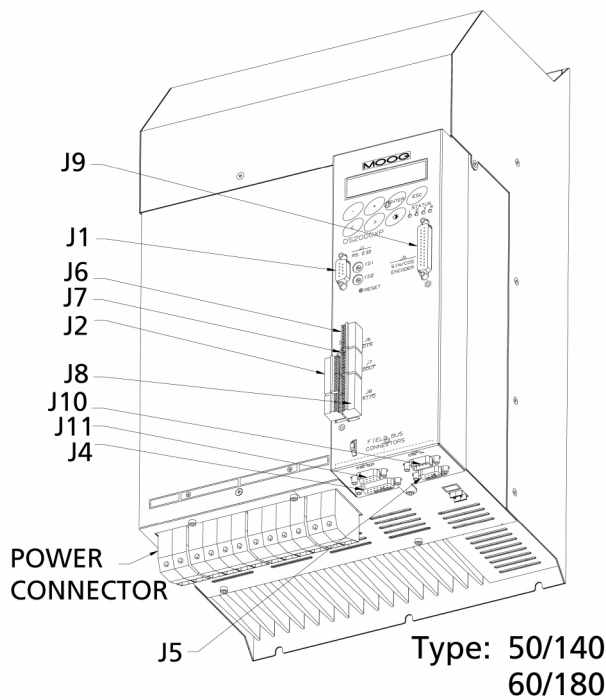

- J1 RS232 Communication
- J2 Servodrive Enable and monitoring
- J4 Motor Encoder feedback
- J5 Motor Resolver feedback
- J6 Digital Input
- J7 Digital Output
- J9 Sin/Cos Encoder feedback (optional)
- J10 CAN in (or SERCOS/FireWire)
- J11 CAN out (or SERCOS/FireWire)
- POWER AC or DC power supply and motor connection

DIMENSIONS

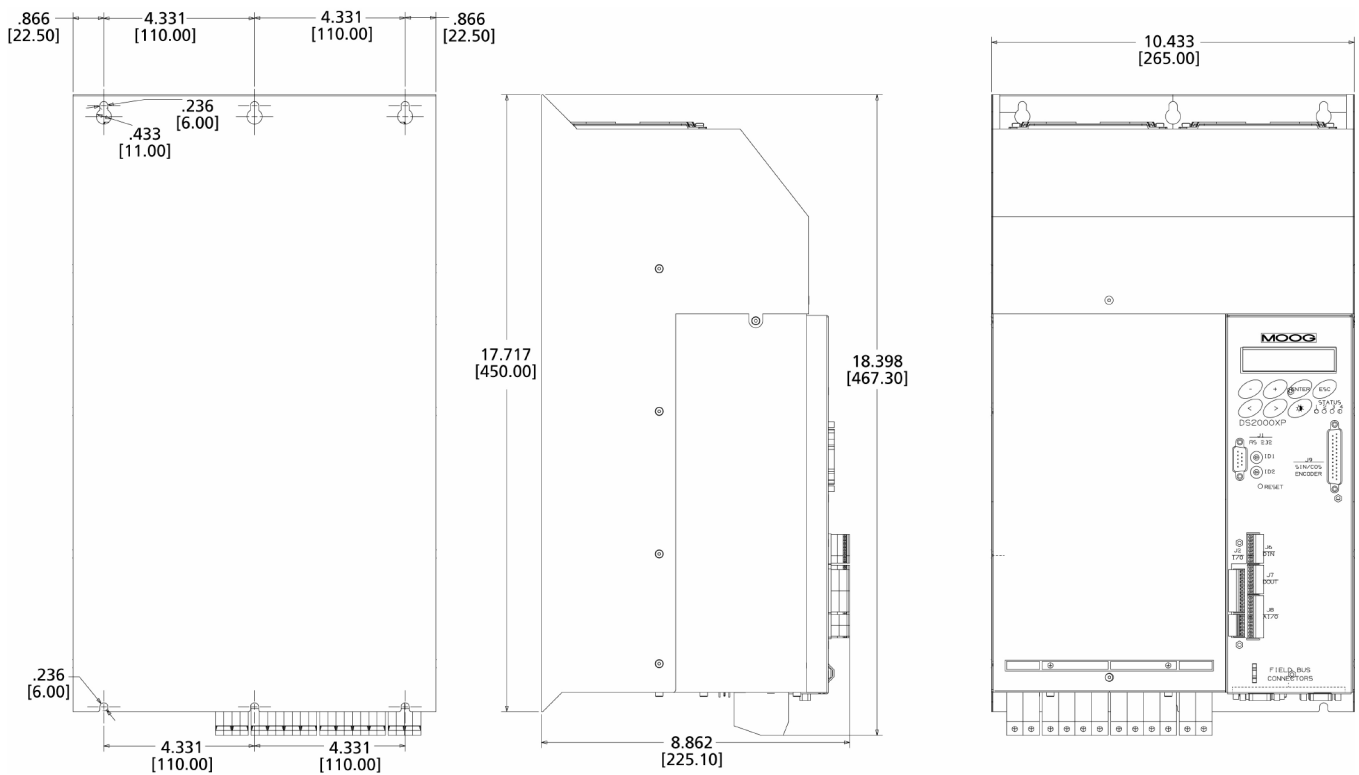

DS2000XP Size E - CONNECTORS AND DESCRIPTION

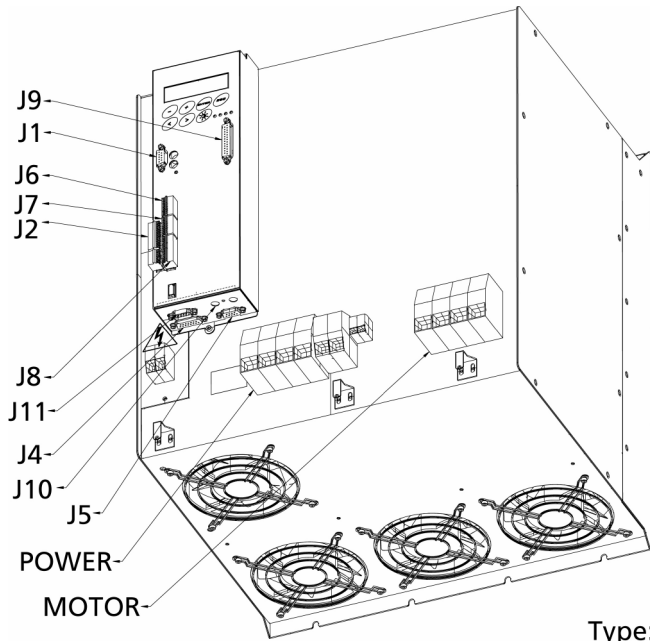

- J1 RS232 Communication
- J2 Servodrive Enable and monitoring
- J4 Motor Encoder feedback
- J5 Motor Resolver feedback
- J6 Digital Input
- J7 Digital Output
- J9 Sin/Cos Encoder feedback (optional)
- J10 CAN in (or SERCOS/FireWire)
- J11 CAN out (or SERCOS/FireWire)
- POWER AC or DC power supply and motor connection

Type: 100/240

DIMENSIONS

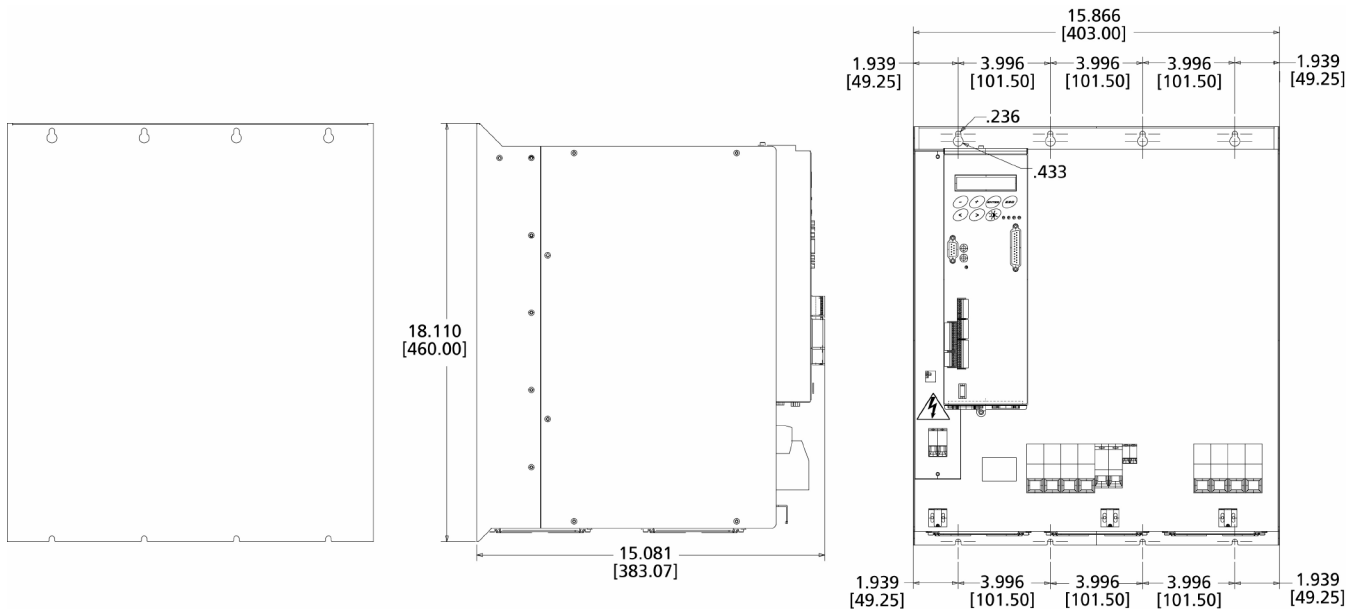

Alpha/Numeric

Alpha

Numeric

Numeric

Alpha

Alpha/Numeric

Model Series Designator

G369

E XXX - XXX

A XXX

Current Model Design Status

Letter

E (Prototype)

- (Standard)

Drive Current Rating

No.	Power Stage Rating (Acont/Apk)
003	3/9
004	4/12
006	6/15
008	8/22
014	14/42
020	20/45
025	25/70
030	30/90
050	50/140
060	60/180
100	100/240

Drive Control Stage

No.	Control Stage Part No.	Amps	Control Stage Description
101	C27345-122-000	100	SERCOS Communications ±10 V Analog O/P
	C27345-122-905	100	SERCOS Communications ±10 V Analog O/P, 905 configuration
122	C27345-122-000	14	SERCOS Communications 0-20 mA Analog I/O
	C27345-122-905	14	SERCOS Communications 0-20 mA Analog I/O, 905 configuration
211	C27345-211-000	3	CANopen Communications ±10 V Analog I/O
	C27345-211-905	3	CANopen Communications ±10 V Analog I/O, 905 configuration
222	C27345-222-000	8	CANopen Communications 0-20 mA Analog I/O
	C27345-222-905	8	CANopen Communications 0-20 mA Analog I/O, 905 configuration
233	C27345-233-000	30	CANopen Communications ±10 V & 0-20 mA Analog I/O
	C27345-233-905	30	CANopen Communications ±10 V & 0-20 mA Analog I/O, 905 config.
310	C27345-310-000	8	FireWire Communications ±10 V Analog I/P
	C27345-310-000	14	FireWire Communications ±10 V Analog I/P
	C27345-310-000	100	FireWire Communications ±10 V Analog I/P
	C27345-310-905	8	FireWire Communications ±10 V Analog I/P, 905 configuration
	C27345-310-905	14	FireWire Communications ±10 V Analog I/P, 905 configuration
320	C27345-610-000	14	FireWire Communications 0-20 mA Analog I/P
	C27345-610-905	14	FireWire Communications 0-20 mA Analog I/P, 905 configuration
	C27345-822-904	14	Cold Plate, CANopen Communications 0-20 mA Analog I/O, 904 config.

Current Hardware Revision

Letter

A

Customer Identifier

No.	Customer software version and revision
000	Generic customer configuration
XXX	Specific customer configuration

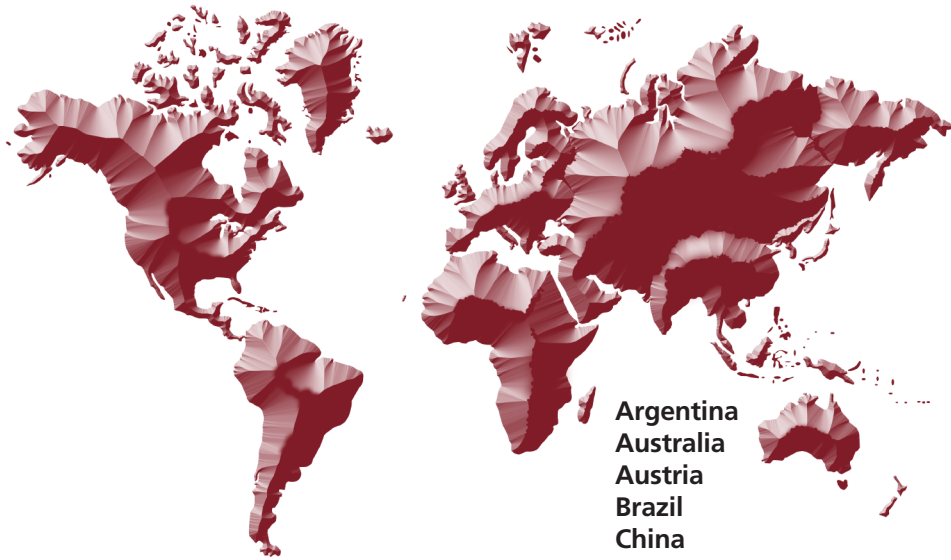

**Argentina
Australia
Austria
Brazil
China
Finland
France
Germany
India
Ireland**



**Italy
Japan
Korea
Luxembourg
Norway
Russia
Singapore
South Africa
Spain
Sweden
United Kingdom
USA**

MOOG

Moog Inc., Industrial Controls
USA: +1-716-652-2000
Germany: +49-7031-622-0
Japan: +81-463-55-3615
For the location nearest you, visit
www.moog.com/worldwide.

DS2000XP Servodrives CDL7071 500-541 0505