

# Electrifying the FEEL of FLIGHT

Electric actuators replace hydraulics in full-flight simulators while still maintaining that aircraft "feel."

Authored by:

**Dr. Sunil Murthy**

Marketing Manager

**Moog Industrial Group**

East Aurora, N.Y.

Edited by **Robert Repas**

robert.repas@penton.com

## Key points

- Full-flight simulators (FFS) replicate the real "feel" of the simulated aircraft.
- A 12-pole, brushless servomotor with custom rotor and stator design delivers 5,600 lb-in.
- The custom-designed ball screw gives operational smoothness without added noise or vibration.

## Resources

*Aviation Safety* magazine,  
[aviationsafetymagazine.com](http://aviationsafetymagazine.com)

CAE, [cae.com](http://cae.com)

FlightSafety International, [flightsafety.com](http://flightsafety.com)

Moog Industrial Group, [www.moog.com](http://www.moog.com)

Every aircraft flies with its own special feel stemming from its flying and handling parameters. Pilots develop a special sense tuned to the feel of the plane that lets them react appropriately in different situations. Proper pilot reactions are the difference between just flying and flying safely.

The flight-simulation industry is there to let pilots learn the “feel” aspects of flying without the hazards and cost of flying an actual aircraft. According to *Aviation Safety* magazine, “the high-quality simulator training airline flight-crew members receive from the very first days of their employment” is “the most significant factor” in helping pilots fly safely. Yet, one of the greatest motion-control challenges anywhere lies in simulating realistic flight conditions.

Motion-control systems for full-flight simulators must replicate the conditions and forces that pilots routinely encounter — and new pilots must master — before earning a flight license or rating. Simply put, these motion-control systems contain sophisticated hardware and software intelligence to move a flight simulator and pilot through a virtual sky. Specifically, the motion-control system must seamlessly integrate the operation of a six-degree-of-freedom (6DOF) motion base with control loading hardware that recreates the action and response of primary and secondary control systems, total cockpit instrumentation, and sophisticated visual displays in the cabin.

Hydraulic motion-control systems ruled the flight simulation world for more than 40 years. While there were attempts to create all-electric systems, the results typically fell short in performance or the higher investment needed to own the system deterred customers. So economical all-electric motion-control systems for flight simulation are an engineering breakthrough of sorts.

### The electric challenge

Though hydraulic motion-control systems met the performance specifications for full-flight simulators, all-electric systems offer several advantages over hydraulic motion control such as higher energy efficiency, higher uptime from lower maintenance, and a less-costly infrastructure. Hydraulic infrastructures need a significant up-front investment. For example, trenches for hydraulic lines, hydraulic power rooms,



**The underside of a FlightSafety International full-flight simulator shows the six electric linear actuators that move the “cockpit” of the simulator to replicate the flying parameters of various aircraft. The hexapod arrangement lets the cockpit travel through six degrees-of-freedom (6DOF) .**

manifolds, filters, temperature controls for hydraulic fluid, and so forth, add to the overall cost of installation. In addition, hydraulic power is environmentally less friendly because of oil leaks, spills, and the need to periodically dispose of used hydraulic fluids. High uptimes found in all-electric systems are attractive to flight training schools as many schools schedule training on a 24/7 basis almost a year in advance.

Despite the benefits, several factors kept all-electric flight training

systems from taking off. For one thing, early servomotors lacked the power density for stroke and payload systems over 30,000 lb (14,000 kg.) High-power industrial servodrives lacked the power devices and processors that today make them commercially attractive. Safety systems also posed additional challenges. In case of a power loss, hydraulic systems have reserve pressurized fluid that lets them return home to a “park” position for safe exit by the crew. Electric actuators, however, need



power to bring the simulator back to the park position. Pilots “flying” these early electric motion-control systems reported the feel was different than hydraulic-based systems. That realistic feel is often subjective and is ultimately determined by an experienced pilot trainer.

### Electric actuators take flight

The primary technical challenges for engineers moving from hydraulic to electric actuation were: handling a high payload with high-power motion control; meeting the high-fidelity requirements, or smoothness of motion, at such high power; and ensuring safety along with cushioning to protect the pilot and equipment from damage. For commercial viability, the Level D certification of an all-electric full-flight simulator by the U.S. Federal Aviation Administration (FAA) was the most critical challenge.

Companies that build full-flight simulators (FFS) for commercial aircraft flight training, like **FlightSafety International** (FSI, Broken Arrow, Okla.) and **CAE** (Montreal, Canada), must receive Level D certification from the FAA before their systems can be used for pilot training in the U.S. Level D certification guarantees that the simulator experience is realistic enough to be the equivalent of hours flown in the air. To meet specifications for Level D certification, simulators need the highest levels of fidelity and safety of any commercial motion-control system.

The benefits of an all-electric system drove some engineers to look for ways to create an all-electric FFS better than the hydraulic-based FFS. The first manufacturer to tap improved electric technology and apply it to flight simulation was **Moog Inc.** of East Aurora, NY. Moog presented the concept of all-electric motion systems for full-flight simulators with several FFS manufacturers that used Moog’s high-performance servovalves in their hydraulic motion systems.

Among the advances in electric technology that aided engineers in their quest was ball-screw technology. Industry experts agree that the ball screw, a device that translates rotation into linear movement,



**All-electric simulators, like this CAE 5000 Series, bring green technology to flight training. Though both hydraulic and electric simulators save fuel and other major costs of operating an aircraft for training purposes, all-electric systems eliminate worries about environmental contamination from hydraulic oil leaks or disposal of used oil. This makes for cleaner and safer operation and helps reduce maintenance, so more simulator time is available for flight training.**

makes up one of the most important components in electric actuators to ensure the high fidelity needed for this application.

Moog developed ball-screw technology for this application that offers high fidelity levels with low audible and transmitted disturbances. That means smooth actuator operation did not add any noise or vibration to the flight experience that were not part of the aircraft being simulated. Such levels

were not possible just a decade ago and needed substantial effort in the design of special ball transfer inserts, manufacturing techniques and tolerance control, and 100% unit testing.

Control electronics benefited as well from faster and more-powerful processors and larger memory capacities. Advances in higher-voltage power devices drove the development of high-power servodrives. High-energy magnets boosted power density in brushless motors.

## All-electric flight-simulator block diagram

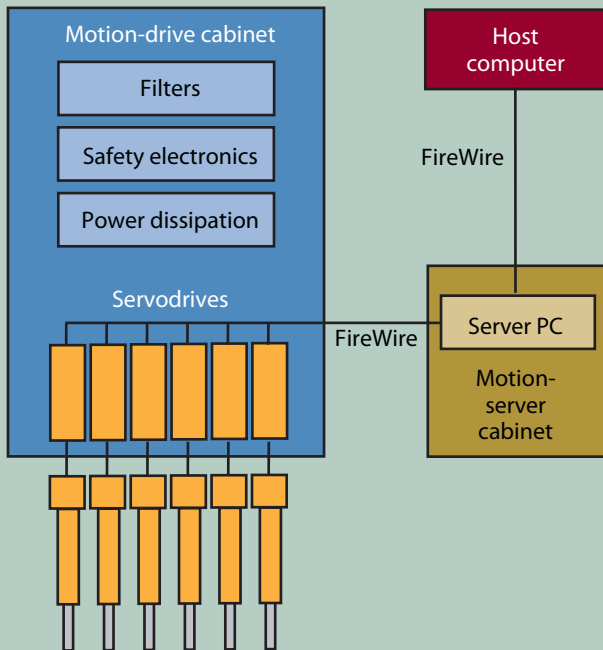

**A block diagram of an all-electric full-flight simulator identifies the basic components of the electric drive system and how everything interconnects.**

Electric-actuator stroke lengths grew to 152 cm (60 in.) for payloads approximating 30,000 lb (14,000 kg).

Engineers at Moog undertook the design of electric actuators for the motion base, control loading, servodrives, and the communications software to exchange data with the FFS host computer. FSI modified its flight control system to work with the Moog-designed 6DOF electric-motion base.

A helicopter-control loading fixture from FSI let Moog test its prototype for validation. This test system let Moog accelerate software integration between the host computer and the Moog hardware as well as eliminate sources of vibration or torque ripple, minimizing the time needed to get Level D certification.

To meet application needs, Moog engineers rearchitected their standard servodrives by incorporating high-performance microprocessors to handle the high update rates and computation accuracy needed for current/velocity/position loop control as well as the high-speed communications with the simulator host computer.

Proof-of-concept came via an electric actuator built on a test stand with a prototype control. Tests revealed smooth operation that rivaled a hydraulic system.

The actuator motor consists of a 12-pole, brushless servomotor with a rotor and stator custom-designed to

deliver 5,600 lb-in. (633 Nm) with low levels of cogging torque, torque ripple, and undesired harmonics. The custom-designed ball-screw and servomotor system easily handled the high payloads involved.

Safety, of course, was still a major concern. An uninterruptible power supply (UPS) gave the system safe fault recovery and continuous logging. In addition, a 48-V battery backup and fail-safe drive system supplied enough power to return the flight simulator cockpit to the park position in the event of a power outage.

During extreme operations, such as flights through simulated storms and high wind shears, it's not unusual for the actuators to bottom-out or reach the end of their travel. While hydraulic cylinders typically had internal systems that prevented damage to the piston and cylinder at extreme travel, the electric actuators had no such limitations. To prevent the actuators from damaging the end stops, Moog developed and patented maintenance-free snubbers (or cushions) for the actuators. The cushions engage 3 in. (7.62 cm) from either end of the stroke to dissipate the kinetic energy of the motion base.

Control of the motion base was only part of the process. Moog also had to develop a linear-electric control loader with adequate fidelity for a full-flight simulator. Control loading is the term given to force feedback sent to the primary and secondary controls used by the pilot.

The feedback simulates the type of "feel" the pilot would get from the controls on an actual plane. It's similar to the feedback sent to steering wheels and joysticks used by gamers playing a video game.

### An electric system gets its wings

In 2006, the world's first all-electric full-flight simulator was awarded the coveted Level D Certification by the Federal Aviation Administration. The close collaboration between Moog and FSI created a FFS that the FAA compared favorably with the true handling and feel of the simulated aircraft. The FAA certification now lets pilots train and qualify for a flight license for that craft.

Since then adoption of all-electric FFSs has grown quickly. *Civil Aviation Training* magazine recently noted there are 1,150 FFSs in use around the world. Of the motion-control solutions for flight simulators now being built and sold, industry experts say more than 85% are electric.

From a green perspective, this makes excellent sense. These systems soak up about 80% less energy than hydraulic-based simulators. Of course, there are no oil or filters to be replaced, nor are there drips and leaks inherent with hydraulic systems. Finally, less downtime for maintenance ups the time the simulator is available for training, a fact that improves cost-of-ownership. **MD**